

LAKE HAVASU CITY

**ENGINEERING
DIVISION**

**STANDARD
DETAILS**

200 SERIES: ROADWAY DETAILS

- 200 UTILITY TRENCH PATCH
- 201 DRIVEWAY IMPROVED STREET
- 202 DRIVEWAY UNIMPROVED STREET
- 203A STREET & SIDEWALKS CROSS SECTIONS - ELEVATIONS (ALL ZONES)
- 203B STANDARD SECTIONS OF STREETS & SIDEWALKS
- 204 STREET-STREET INTERSECTION SINGLE & MULTIPLE DRIVEWAYS
- 205 INTERSECTION & MULTIPLE DRIVEWAYS
- 206 STREET & DRIVEWAY INTERSECTION (ZONE R-3 OR GREATER)
- 207 ACCESSIBLE RAMP STREET/STREET INTERSECTIONS
- 208 ACCESSIBLE RAMP STREET/DRIVEWAY INTERSECTION
- 209 ACCESSIBLE RAMP STREET/ALLEY INTERSECTION
- 210 ACCESSIBLE RAMP SIDEWALK/STREET INTERSECTION
- 211 PARALLEL CURB RAMP
- 212 6" EXTRUDED VERTICAL CURB
- 213 VERTICAL CURB
- 214 VERTICAL CURB AND GUTTER
- 215 ROLLED CURB AND GUTTER
- 216 ALTERNATE SIDEWALK/CURB
- 217 SIGHT DISTANCE TRIANGLE
- 218 CUL-DE-SAC PAVEMENT
- 219 AC PATCH

300 SERIES: WATER DETAILS

- 300 VALVE/VALVE RISER
- 301 1" SERVICE CONNECTION
- 302 2" SERVICE CONNECTION
- 303 1" SERVICE TAP
- 304 1.5" - 2" SINGLE SERVICE TAP
- 305 1.5" - 2" WATER METER ASSEMBLY
- 306 1.5" - 2" WATER METER BY PASS ASSEMBLY

300 SERIES: WATER DETAILS

- 307 COMMERCIAL DOUBLE CHECK VALVE ASSEMBLY w/ FIRE DEPT. CONNECTION
- 308 PRESSURE REDUCING ASSEMBLY
- 309 DOUBLE CHECK VALVE ASSEMBLY
- 310 1" COMBINATION AIR/VACUUM VALVE & 2" BLOW-OFF
- 311 2" COMBINATION AIR/VACUUM VALVE & 2" BLOW-OFF
- 312 4" COMBINATION AIR/VACUUM VALVE
- 313 2" BLOW-OFF ASSEMBLY IN LINE
- 314 2" BLOW-OFF ASSEMBLY END OF LINE
- 315 4" BLOW-OFF ASSEMBLY
- 316 HOT TAP w/ GATE VALVE
- 317 TRUST BLOCKS FOR WATER LINES
- 318 TYPICAL DROP UNDER EXISTING WATERLINE
- 319 TYPICAL WASH CROSSING
- 320 6" FIRE HYDRANT

400 SERIES: WASTEWATER DETAILS

- 400 CASING PIPE AND END SEAL
- 401A WATER/SEWER ZONE SEPARATION
- 401B WATER/SEWER ZONE SEPARATION NOTES
- 401C WATER/SEWER ZONE SEPARATION & ENCASEMENT FOR PIPE CROSSING
- 402 MANHOLE INVERT
- 403 PRECAST CONCRETE MANHOLE
- 404 OUTSIDE DROP MANHOLE
- 405 SHALLOW PRECAST CONCRETE MANHOLE
- 406 MANHOLE CASTING COVER
- 407 INLINE CLEANOUT
- 408 TYPICAL END OF LINE CLEANOUT
- 409 SEWER SERVICE CONNECTION VACANT LOT
- 410 SEWER SERVICE CONNECTION TO EXISTING LOT
- 411 FORCE MAIN CONNECTION
- 412 BACKWATER VALVE
- 413 PIPE SUPPORT SADDLE
- 414 TYPICAL WALL PIPE



LAKE HAVASU CITY



Standard Details

Index Page (1 of 2)

Detail No.

100-1

400 SERIES: WASTEWATER DETAILS

- 415 HARNESSED SLEEVE COUPLING
TIED-ROD
- 416 WALL PIPE SUPPORT
- 417 COMBINATION AIR/SEWER RELEASE
VALVE MANHOLE
- 418 COMBINATION AIR/SEWER RELEASE
VALVE
- 419 PUMP STATION SECTION
- 420 PUMP STATION PLAN VIEW
- 421 FORCE MAIN METER VAULT BASE SLAB
PLAN
- 422 FORCE MAIN METER VAULT SECTION
- 423 FORCE MAIN METER VAULT TOP SLAB
PLAN
- 424 TYPICAL PUMP STATION CMU SCREENED
WALL

600 SERIES: FIRE

- 600 FIRE DEPARTMENT STANDARD RISER
DETAIL

500 SERIES: STORMWATER DETAILS

- 500 DEPRESSED CURB OPENING
- 501 SCUPPERS
- 502A STABILIZED CONSTRUCTION ENTRANCE
(COMMERCIAL)
- 502B STABILIZED CONSTRUCTION ENTRANCE
(RESIDENTIAL)
- 503 INSTALLATION OF EROSION CONTROL
MATS
- 504A WATTLE NOTES
- 504B WATTLE DETAILS
- 504C WATTLE SECTION
- 505 ORGANIC FILTER BARRIER
- 506A CONCRETE WASHOUT (STRAW BALES)
- 506B CONCRETE WASHOUT (WOOD PLANKS -
BERMS BELOW & ABOVE)
- 507 GRAVEL FILTER BERM (TRAFFIC AREAS)
- 508 SILT FENCE
- 509 STORM DRAIN DROP INLET PROTECTION
- 510 STORM DRAIN CURB INLET PROTECTION



LAKE HAVASU CITY

Standard Details

Index Page (2 of 2)

Detail No.

100-2

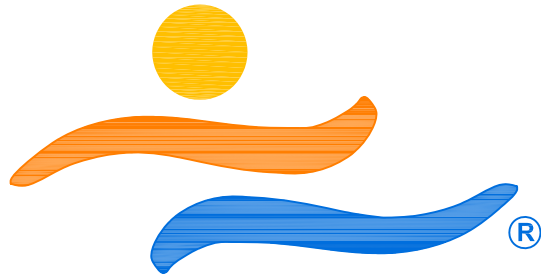

LAKE HAVASU CITY

**ROADWAY
IMPROVEMENTS**

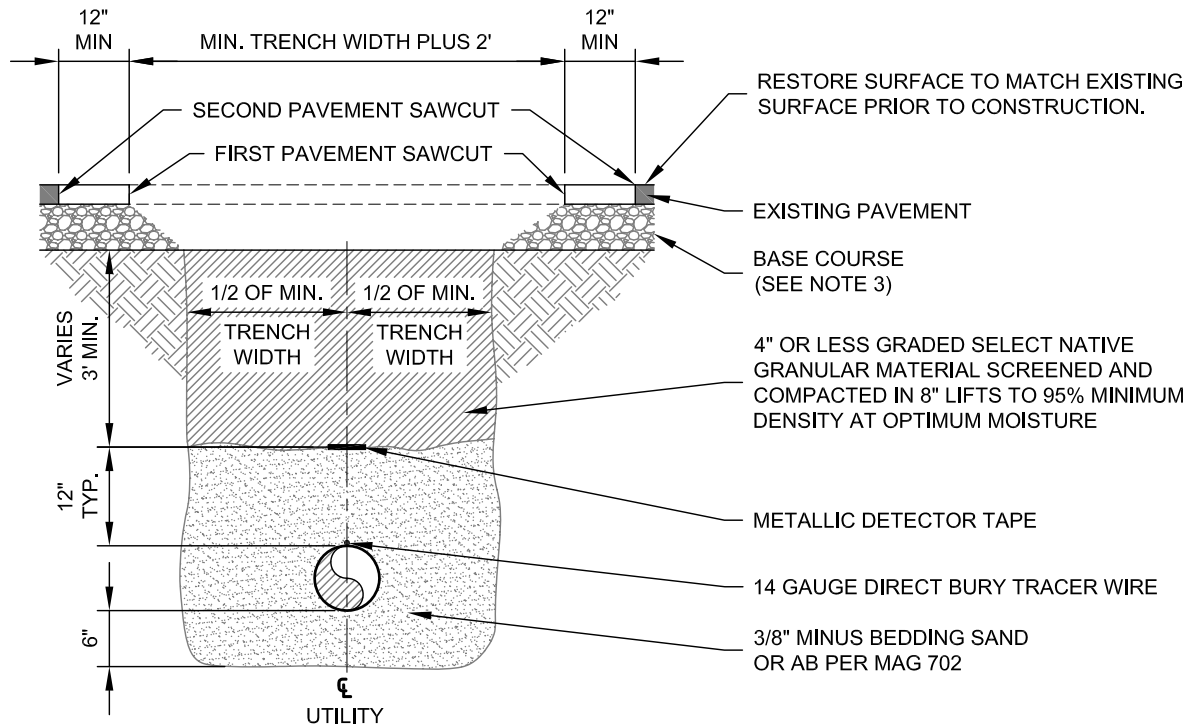

MINIMUM TRENCH WIDTH TABLE				
PIPE DIAMETER	MINIMUM WIDTH	MINIMUM BETWEEN FIRST SAWCUTS	MINIMUM BETWEEN SECOND SAWCUTS	CONCRETE PAVEMENT
<8 IN.	24"	4'	6'	SECOND SAWCUT SHALL BE AT EXISTING JOINTS, SEE NOTE #5
8IN.-12IN.	30"	4'-6"	6'-6"	
14IN.-18IN.	36"	5'	7'	
20IN.-24IN.	42"	5'-6"	7'-6"	
24IN.-36IN.	1.25 (PIPE OD) PLUS 12IN.	MIN. WIDTH PLUS 2'	MIN. WIDTH PLUS 4'	
>36IN.	PER PLANS	MIN. WIDTH PLUS 2'	MIN. WIDTH PLUS 4'	

NOTES:

1. ALL SAWCUTS TO BE FULL DEPTH OF PAVEMENT.
2. PATCH MATERIAL SHALL MATCH THE EXISTING PAVEMENT MATERIAL (eg CONCRETE PAVEMENT SHALL BE PATCHED WITH CONCRETE AND EXISTING ASPHALT PAVEMENT WITH ASPHALT).
3. FOR ASPHALT PATCHES, BASE COURSE & ASPHALT CONCRETE THICKNESS IS TO MATCH EXISTING BUT IN NO CASE LESS THAN 0" BASE 2" ASPHALT CONCRETE.
4. ALL EXISTING VERTICAL ASPHALT JOINTS SHALL BE TACK COATED.
5. FINAL CONCRETE PAVEMENT REMOVALS SHALL BE TO THE NEAREST EXISTING JOINT (eg FULL PANEL REMOVAL AND REPLACEMENT).
6. TRENCHES ARE SHOWN TO DIAGRAM PATCHING REQUIREMENTS. TRENCHES SHALL BE CONSTRUCTED TO MEET OSHA REQUIREMENTS.
7. PAVEMENT REMOVAL BETWEEN FIRST AND SECOND SAW CUT SHALL BE REMOVED AT TIME OF HOT MIX PATCHING . DENSITY TESTING SHALL BE AT THE EXPENSE OF THE CONTRACTOR AND A COPY OF RESULTS SHALL BE PROVIDED TO THE CITY.
9. MONITOR & MAINTAIN SURFACE CONDITION AND PERFORM ASPHALT REPAIRS UNDER 1-YEAR WARRANTY PROVIDED THROUGH PERMIT.
10. ALL PATCH JOINTS SHOULD BE HENRY ASPHALT RESURFACER SEALED OR APPROVED EQUAL.

	Standard Details	Utility Trench Patch	Scale: <u>N.T.S.</u>
	Roadway Improvements		Detail No. 200

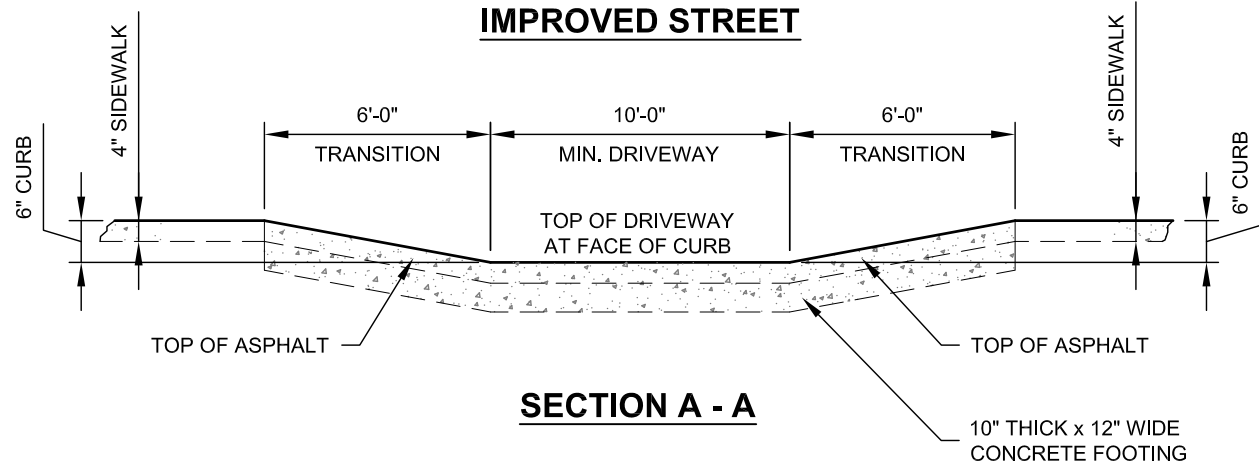
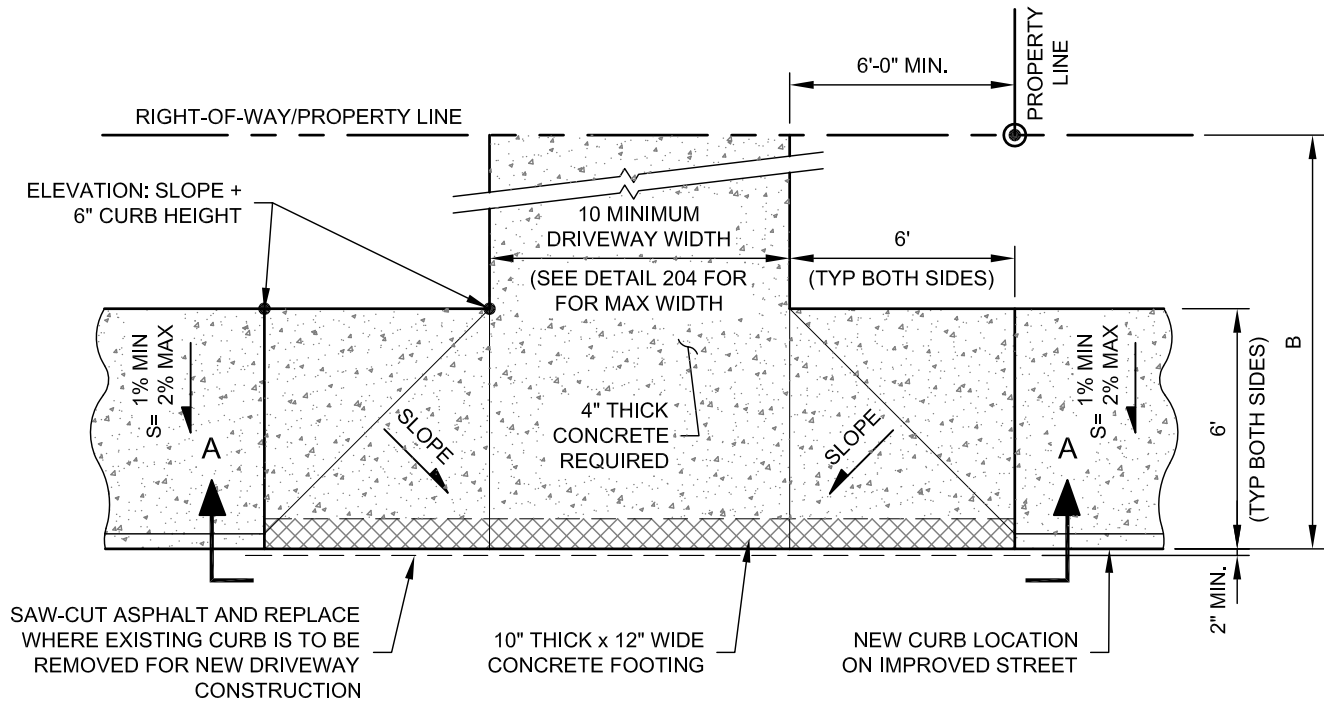

**DISTANCE & ELEVATION TABLE ('W' SECTION)
ABOVE EXISTING EDGE OF PAVEMENT AT 2% SLOPE
(BASED ON 12" EXISTING ASPHALT LANE)**

STREET	RISE	DISTANCE B
BOULEVARD	4"	15 FEET
AVENUE	3"	13 FEET
DRIVE	3"	9 FEET

NOTES:

- ELEVATION AT PROPERTY LINE TO REMAIN 11" ABOVE EDGE OF STREET ON 'W' SECTIONS.
- CONCRETE FOR STRUCTURES IN RIGHT-OF-WAY SHALL BE A 6 SACK PER CUBIC YARD MIX WITH A 4" MAXIMUM SLUMP AND BE ABLE TO PASS A 3,000 PSI COMPRESSIVE STRENGTH TEST AT 28 DAYS.
- SIDEWALK CROSS-SLOPE (BACK OF SIDEWALK TO CURB) TO BE 1.5% MIN / 2% MAX.

	Standard Details	Driveway Improved Street	Scale: <u>N.T.S.</u>
	Roadway Improvements		Detail No. 201

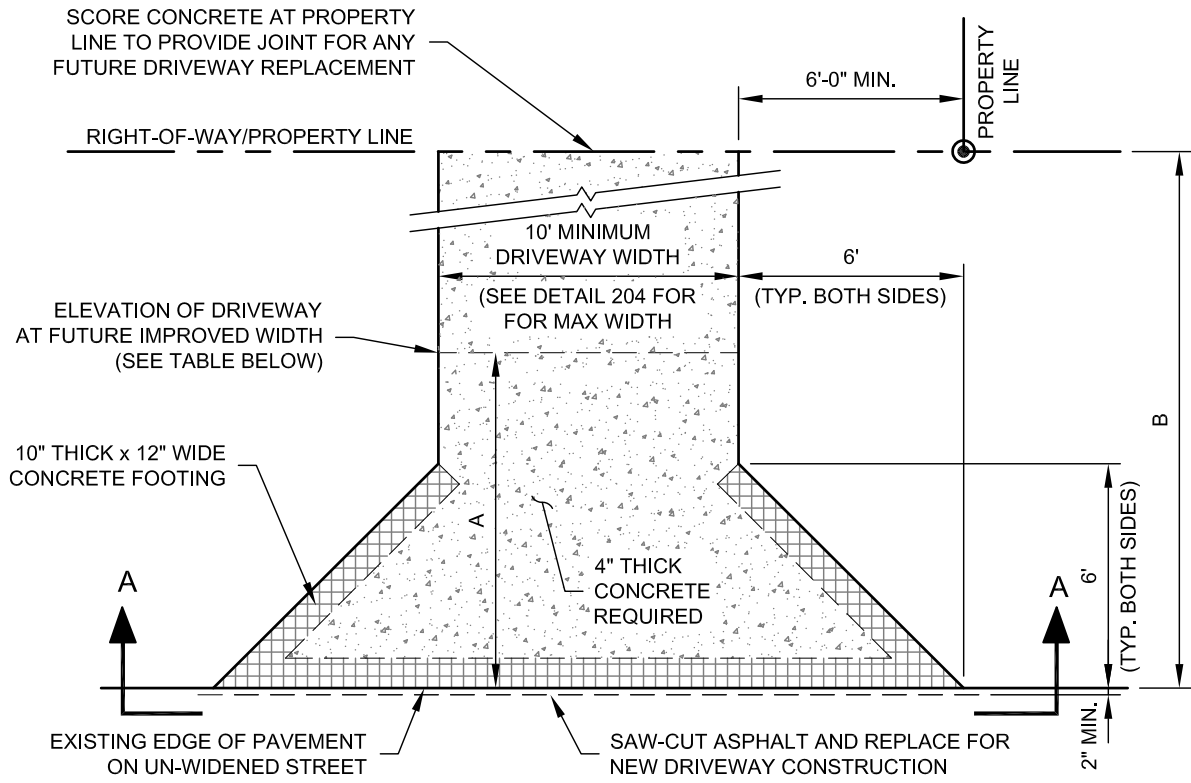

UNIMPROVED STREET

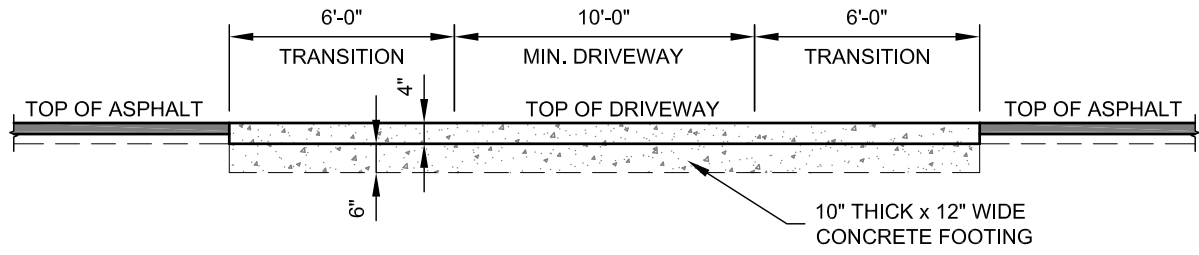

SECTION A - A

DISTANCE & ELEVATION TABLE ('W' SECTION) ABOVE EXISTING EDGE OF PAVEMENT AT 2% SLOPE (BASED ON 12' EXISTING ASPHALT LANE)			
STREET	DISTANCE 'A'	RISE	DISTANCE 'B'
BOULEVARD	15 FEET	4"	30 FEET
AVENUE	10 FEET	3"	23 FEET
DRIVE	9 FEET	3"	18 FEET

NOTES:

1. ELEVATION AT PROPERTY LINE TO REMAIN 11" ABOVE EDGE OF STREET ON 'W' SECTIONS.
2. CONCRETE FOR STRUCTURES IN RIGHT-OF-WAY SHALL BE A 6 SACK PER CUBIC YARD MIX WITH A 4" MAXIMUM SLUMP AND BE ABLE TO PASS A 3,000 PSI COMPRESSIVE STRENGTH TEST AT 28 DAYS.
3. SIDEWALK CROSS-SLOPE (BACK OF SIDEWALK TO CURB) TO BE 1.5% MIN / 2% MAX.

	Standard Details	Driveway Unimproved Street	Scale: <u>N.T.S.</u>
	Roadway Improvements		Detail No. 202

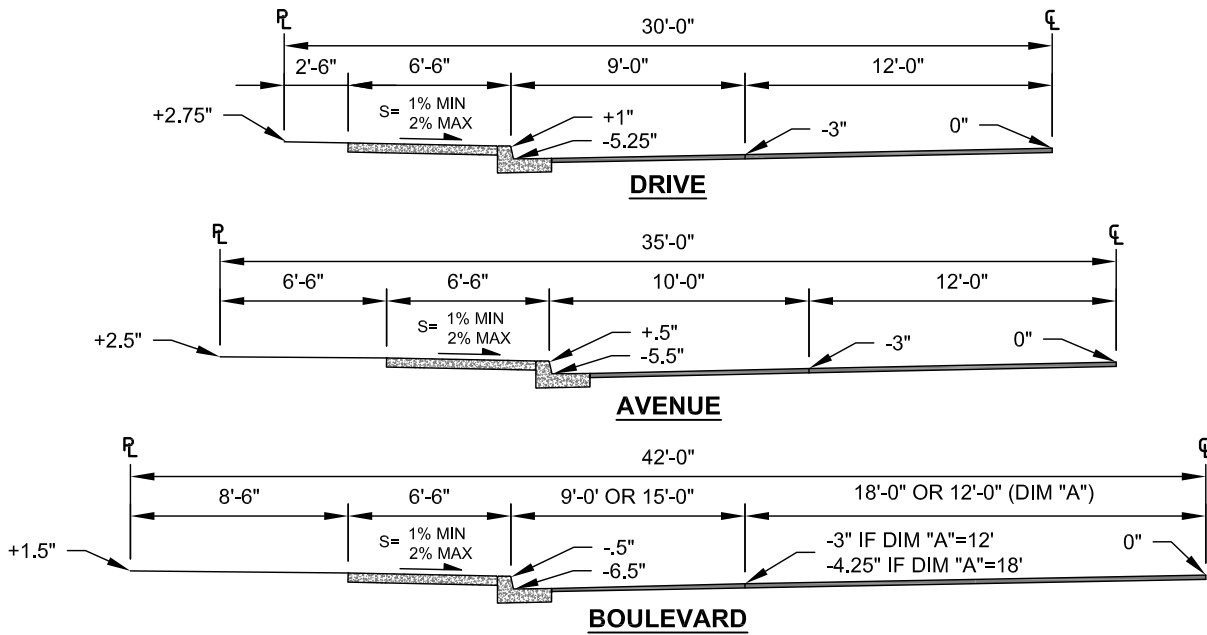

STANDARD SECTION

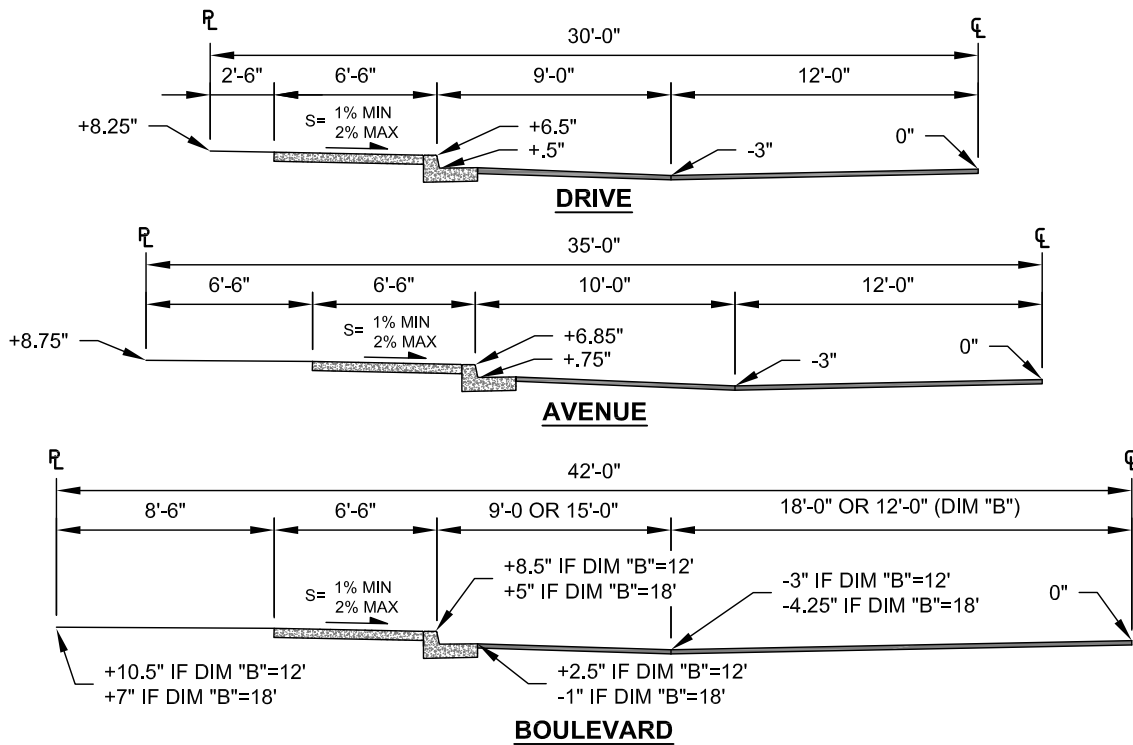

"W" SECTIONS

NOTES:

1. ALL ELEVATIONS SHOWN IN INCHES.
2. ABOVE (+) AND BELOW (-) CENTERLINE ELEVATION.
3. SIDEWALK CROSS-SLOPE (BACK OF SIDEWALK TO CURB) TO BE 1% MIN / 2% MAX.
4. ELEVATION AT PROPERTY LINE TO REMAIN 11" ABOVE EDGE OF STREET ON 'W' SECTIONS.

	<p>Standard Details</p>	<p>Street & Sidewalk Cross Sections Elevations (all zones)</p>	<p>Scale: <u>N.T.S.</u></p>
	<p>Roadway Improvements</p>		<p>Detail No. 203A</p>

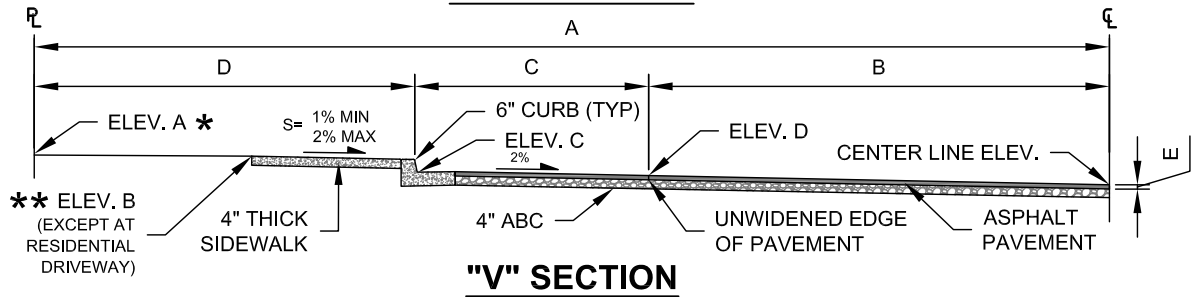
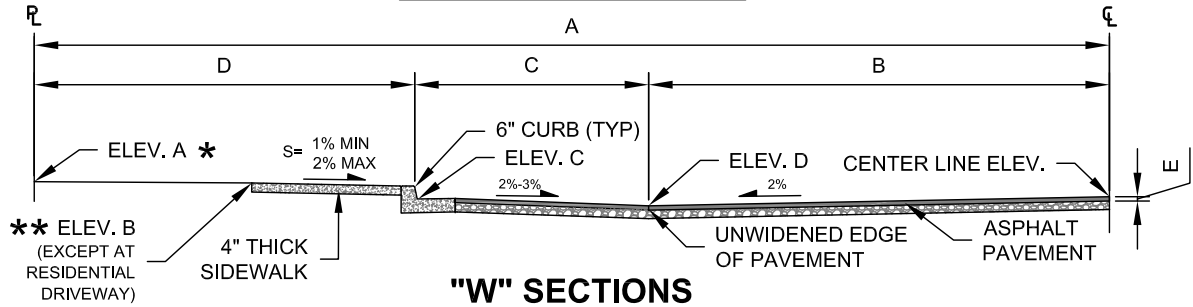
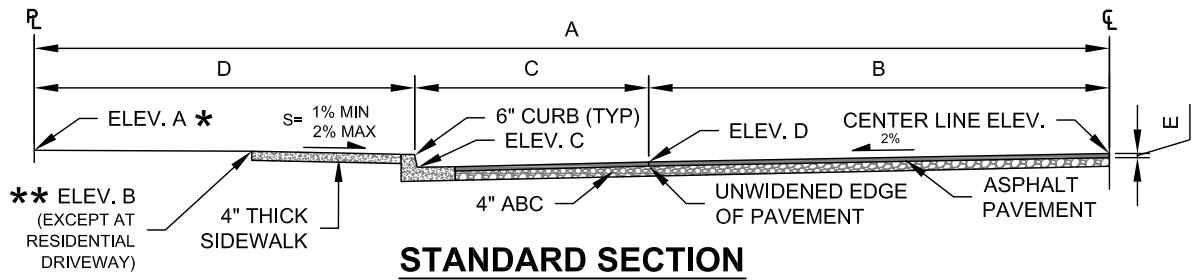

FINISHED ELEVATION (SHOWN IN INCHES ABOVE (+) OR BELOW (-) CENTER LINE)												
STREET	STANDARD SECTION				'W' SECTION				'V' SECTION			
	A (MIN)	B	C	D	A (MIN)	B	C	D	A (MIN)	B	C	D
BOULEVARD	+1.5"	+1"	-6.5"	-4.25"	+7"	+6.5"	-1"	-4.25"	+14.5"	+14"	+6.5"	+4.25"
AVENUE	+2.5"	+2"	-5.5"	-3"	+8.75"	+8.25"	+0.75"	-3"	+13.5"	+13"	+5.5"	+3"
DRIVE	+2.75"	+2.75"	-5.25"	-3"	+8.25"	+8"	+0.5"	-3"	+13.25"	+12.75"	+5.25"	+3"
CUL-DE-SAC	+3.5"	+3"	-4.5"	-3"	N/A	N/A	N/A	N/A	+12.5"	+12"	+4.5"	+3"

DIMENSIONS						
STREET	R/W	A	B	C	D	E
BOULEVARD	84'	42'★	18'★	9'	15'	2"
AVENUE	70'	35'	12'	10'	13'	2"
DRIVE	60'	30'	12'	9'	9'	2"
CUL-DE-SAC	50'	25'	12'	6'	7'	2"

- * UNLESS OTHERWISE APPROVED BY ENGINEERING DIVISION.
- ** ELEVATION 'B' AT RESIDENTIAL DRIVEWAY TO BE ELEVATION 'C' + 6" OR EQUAL TO TOP OF CURB ELEVATION.
- ★ FIELD-VERIFY UNWIDENED PAVEMENT WIDTH. ADJUST DIMENSION 'B' AND 'C' ACCORDINGLY TO EQUAL 27' TOTAL.

NOTES:

1. ALL PAVEMENT WIDENING MUST INCLUDE CURBS.
2. SEE DETAIL 213-216 FOR APPLICABLE CURB DETAIL.
3. "V" SECTION ONLY ALLOWED WITH PRIOR APPROVAL BY THE ENGINEERING DIVISION.
4. INDICATED CURBS, SIDEWALKS AND WIDENING MAY BE EITHER EXISTING OR FUTURE.
5. SIDEWALK CROSS-SLOPE (BACK OF SIDEWALK TO CURB) TO BE 1% MIN / 2% MAX.

SPECIAL NOTES:

1. ENGINEERING DIVISION TO DETERMINE STREET CROSS-SECTION.
2. MINIMUM ELEVATION AT PROPERTY LINE ALONG ENTIRE FRONTAGE OF LOT TO BE IN ACCORDANCE WITH ELEVATION 'A'.

	Standard Details	Standard Sections of Streets & Sidewalks	Scale: <u>N.T.S.</u>
	Roadway Improvements		Detail No. 203B

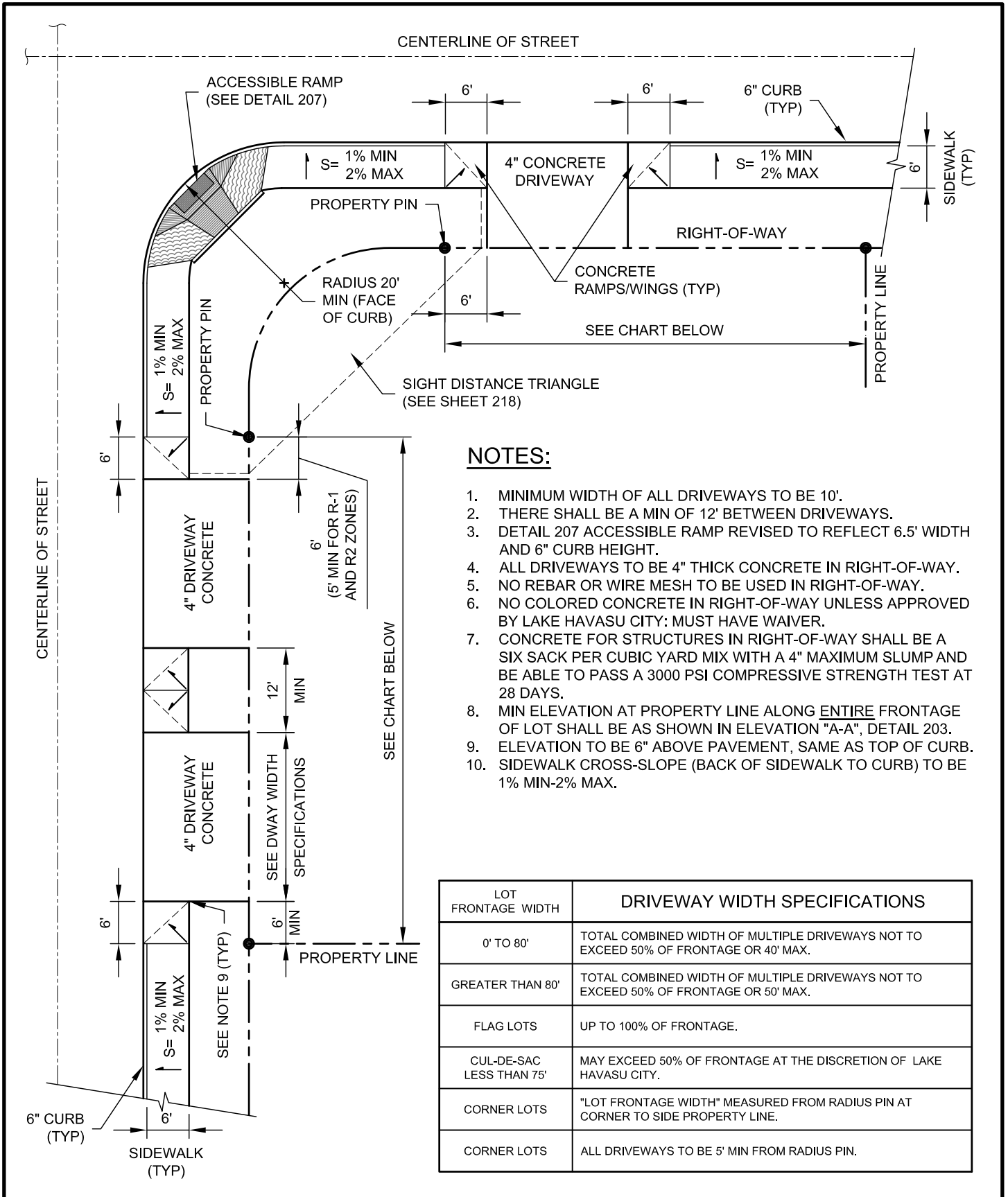

NOTES:

1. MINIMUM WIDTH OF ALL DRIVEWAYS TO BE 10'.
2. THERE SHALL BE A MIN OF 12' BETWEEN DRIVEWAYS.
3. DETAIL 207 ACCESSIBLE RAMP REVISED TO REFLECT 6.5' WIDTH AND 6" CURB HEIGHT.
4. ALL DRIVEWAYS TO BE 4" THICK CONCRETE IN RIGHT-OF-WAY.
5. NO REBAR OR WIRE MESH TO BE USED IN RIGHT-OF-WAY.
6. NO COLORED CONCRETE IN RIGHT-OF-WAY UNLESS APPROVED BY LAKE HAVASU CITY; MUST HAVE WAIVER.
7. CONCRETE FOR STRUCTURES IN RIGHT-OF-WAY SHALL BE A SIX SACK PER CUBIC YARD MIX WITH A 4" MAXIMUM SLUMP AND BE ABLE TO PASS A 3000 PSI COMPRESSIVE STRENGTH TEST AT 28 DAYS.
8. MIN ELEVATION AT PROPERTY LINE ALONG ENTIRE FRONTAGE OF LOT SHALL BE AS SHOWN IN ELEVATION "A-A", DETAIL 203.
9. ELEVATION TO BE 6" ABOVE PAVEMENT, SAME AS TOP OF CURB.
10. SIDEWALK CROSS-SLOPE (BACK OF SIDEWALK TO CURB) TO BE 1% MIN-2% MAX.

LOT FRONTAGE WIDTH	DRIVEWAY WIDTH SPECIFICATIONS
0' TO 80'	TOTAL COMBINED WIDTH OF MULTIPLE DRIVEWAYS NOT TO EXCEED 50% OF FRONTAGE OR 40' MAX.
GREATER THAN 80'	TOTAL COMBINED WIDTH OF MULTIPLE DRIVEWAYS NOT TO EXCEED 50% OF FRONTAGE OR 50' MAX.
FLAG LOTS	UP TO 100% OF FRONTAGE.
CUL-DE-SAC LESS THAN 75'	MAY EXCEED 50% OF FRONTAGE AT THE DISCRETION OF LAKE HAVASU CITY.
CORNER LOTS	"LOT FRONTAGE WIDTH" MEASURED FROM RADIUS PIN AT CORNER TO SIDE PROPERTY LINE.
CORNER LOTS	ALL DRIVEWAYS TO BE 5' MIN FROM RADIUS PIN.

	Standard Details	Street-Street Intersection Single & Multiple Driveways (Zone R-1, R-2, R-E, R-A, R-MH)	Scale: <u>N.T.S.</u>
	Roadway Improvements		Detail No. 204

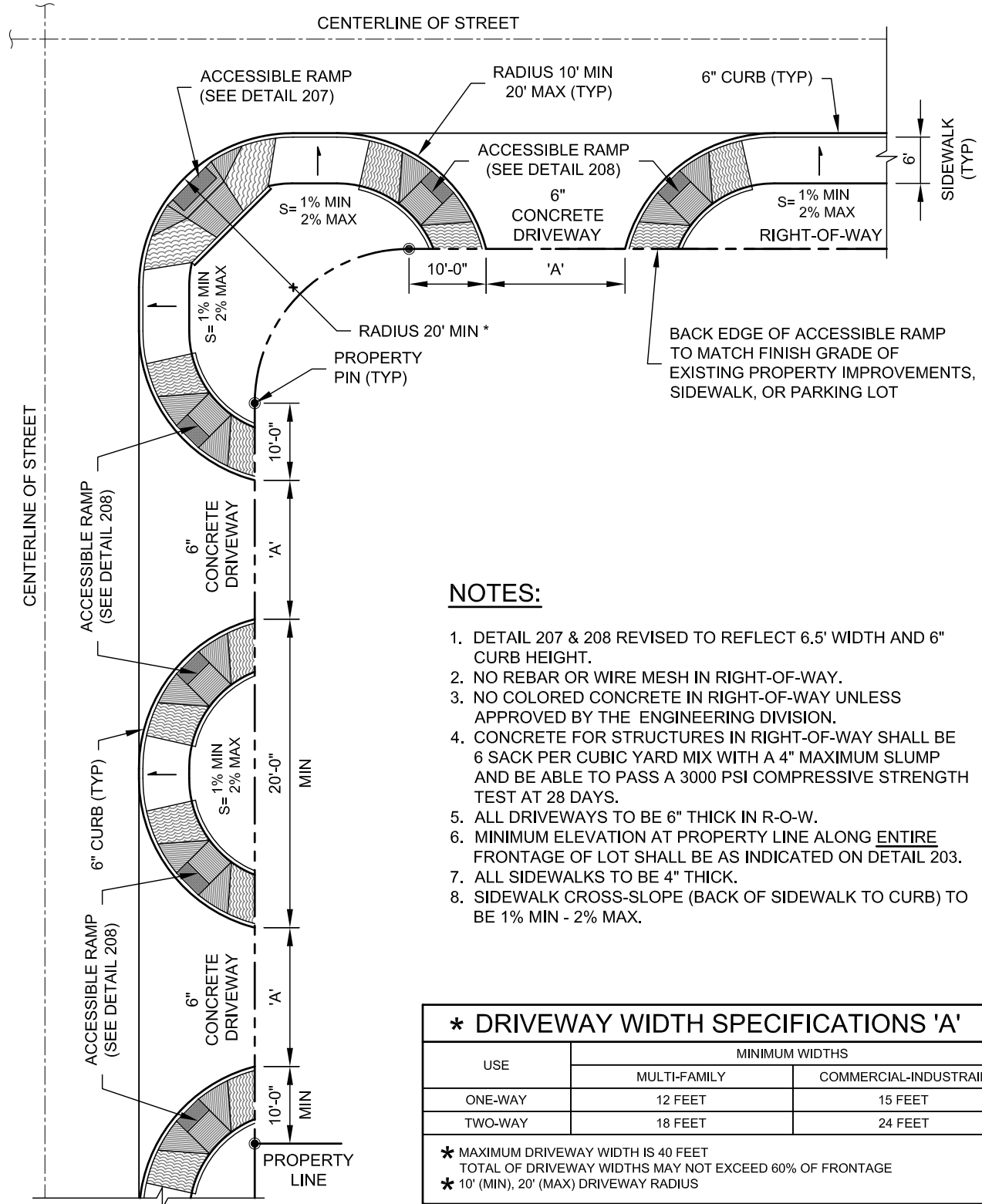

NOTES:

1. DETAIL 207 & 208 REVISED TO REFLECT 6.5' WIDTH AND 6" CURB HEIGHT.
2. NO REBAR OR WIRE MESH IN RIGHT-OF-WAY.
3. NO COLORED CONCRETE IN RIGHT-OF-WAY UNLESS APPROVED BY THE ENGINEERING DIVISION.
4. CONCRETE FOR STRUCTURES IN RIGHT-OF-WAY SHALL BE 6 SACK PER CUBIC YARD MIX WITH A 4" MAXIMUM SLUMP AND BE ABLE TO PASS A 3000 PSI COMPRESSIVE STRENGTH TEST AT 28 DAYS.
5. ALL DRIVEWAYS TO BE 6" THICK IN R-O-W.
6. MINIMUM ELEVATION AT PROPERTY LINE ALONG ENTIRE FRONTAGE OF LOT SHALL BE AS INDICATED ON DETAIL 203.
7. ALL SIDEWALKS TO BE 4" THICK.
8. SIDEWALK CROSS-SLOPE (BACK OF SIDEWALK TO CURB) TO BE 1% MIN - 2% MAX.

*** DRIVEWAY WIDTH SPECIFICATIONS 'A'**

USE	MINIMUM WIDTHS	
	MULTI-FAMILY	COMMERCIAL-INDUSTRIAL
ONE-WAY	12 FEET	15 FEET
TWO-WAY	18 FEET	24 FEET

- * MAXIMUM DRIVEWAY WIDTH IS 40 FEET
- * TOTAL OF DRIVEWAY WIDTHS MAY NOT EXCEED 60% OF FRONTAGE
- * 10' (MIN), 20' (MAX) DRIVEWAY RADIUS

* UNLESS RECOMMENDED IN A TRAFFIC REPORT APPROVED BY LAKE HAVASU CITY.

	Standard Details	Intersection & Multiple Driveways	Scale: <u>N.T.S.</u>
	Roadway Improvements		Detail No. 205

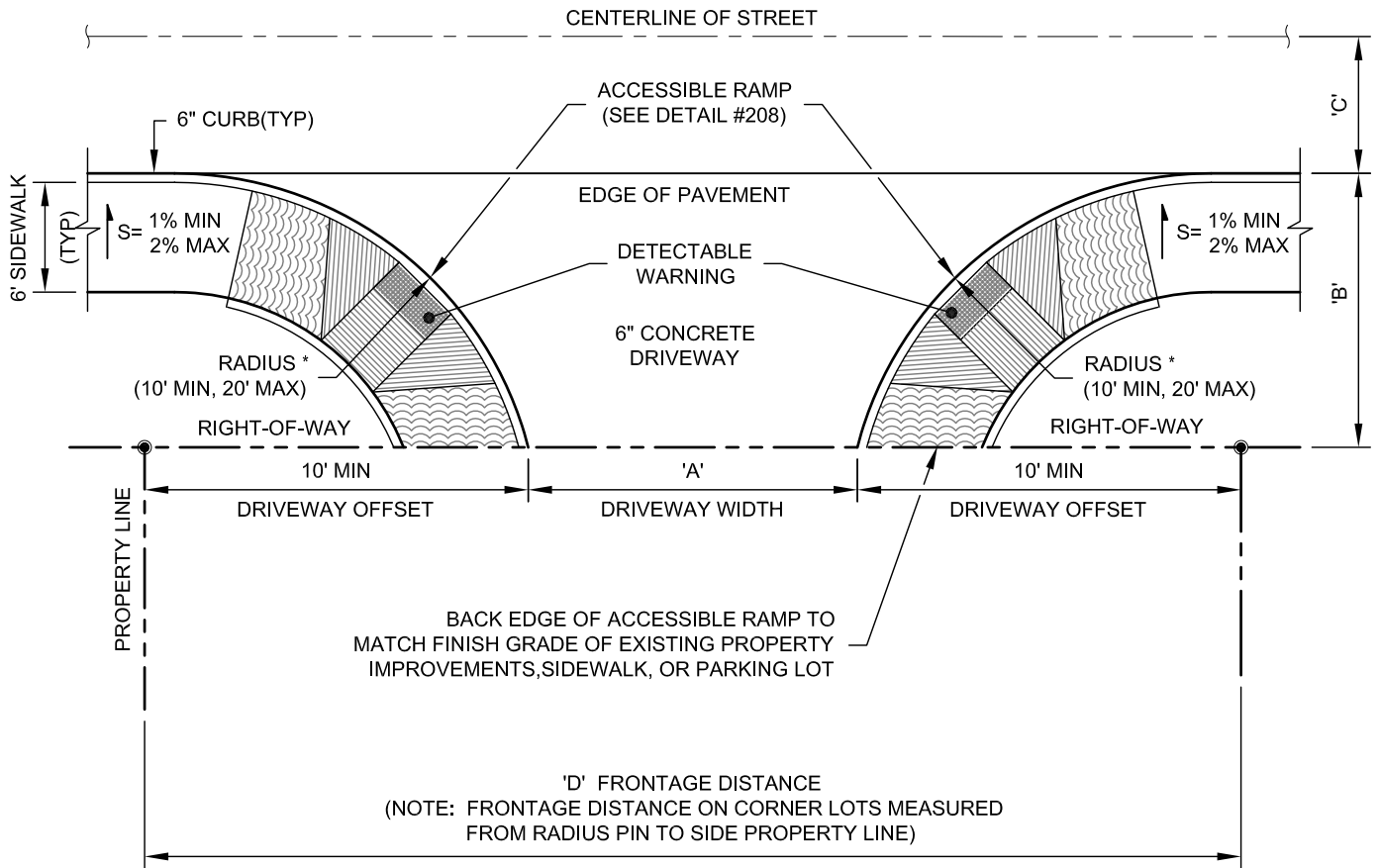

STREET WIDTH DATA		
STREET	'B'	'C'
BOULEVARD	15 FEET	27 FEET
AVENUE	13 FEET	22 FEET
DRIVE	9 FEET	21 FEET
CUL-DE-SAC	7 FEET	18 FEET

DRIVEWAY WIDTH SPECIFICATIONS 'A' *		
USE	MINIMUM WIDTHS	
	MULTI-FAMILY	COMMERCIAL-INDUSTRIAL
ONE-WAY	12 FEET	15 FEET
TWO-WAY	18 FEET	24 FEET

* MAXIMUM DRIVEWAY WIDTH IS 40 FEET
 * TOTAL OF DRIVEWAY WIDTHS MAY NOT EXCEED 60% OF FRONTAGE 'D'
 * 10' (MIN), 20' (MAX) DRIVEWAY RADIUS

* UNLESS RECOMMENDED IN A TRAFFIC REPORT APPROVED BY LAKE HAVASU CITY.

NOTES:

1. ALL SIDEWALKS TO BE 4" THICK CONCRETE.
2. ALL DRIVEWAYS TO BE 6" THICK CONCRETE.
3. NO REBAR OR WIRE MESH IN RIGHT-OF-WAY.
4. NO COLORED CONCRETE IN RIGHT-OF-WAY UNLESS APPROVED BY LAKE HAVASU CITY.
5. CONCRETE FOR STRUCTURES IN RIGHT-OF-WAY SHALL BE A 6 SACK PER CUBIC YARD MIX WITH A 4" MAXIMUM SLUMP AND BE ABLE TO PASS A 3000 PSI COMPRESSIVE STRENGTH TEST AT 28 DAYS.
6. SIDEWALK CROSS-SLOPE (BACK OF SIDEWALK TO CURB) TO BE 1% MIN / 2% MAX.

	Standard Details	Street & Driveway Intersection (Zone R-3 or Greater)	Scale: <u>N.T.S.</u>
	Roadway Improvements		Detail No. 206

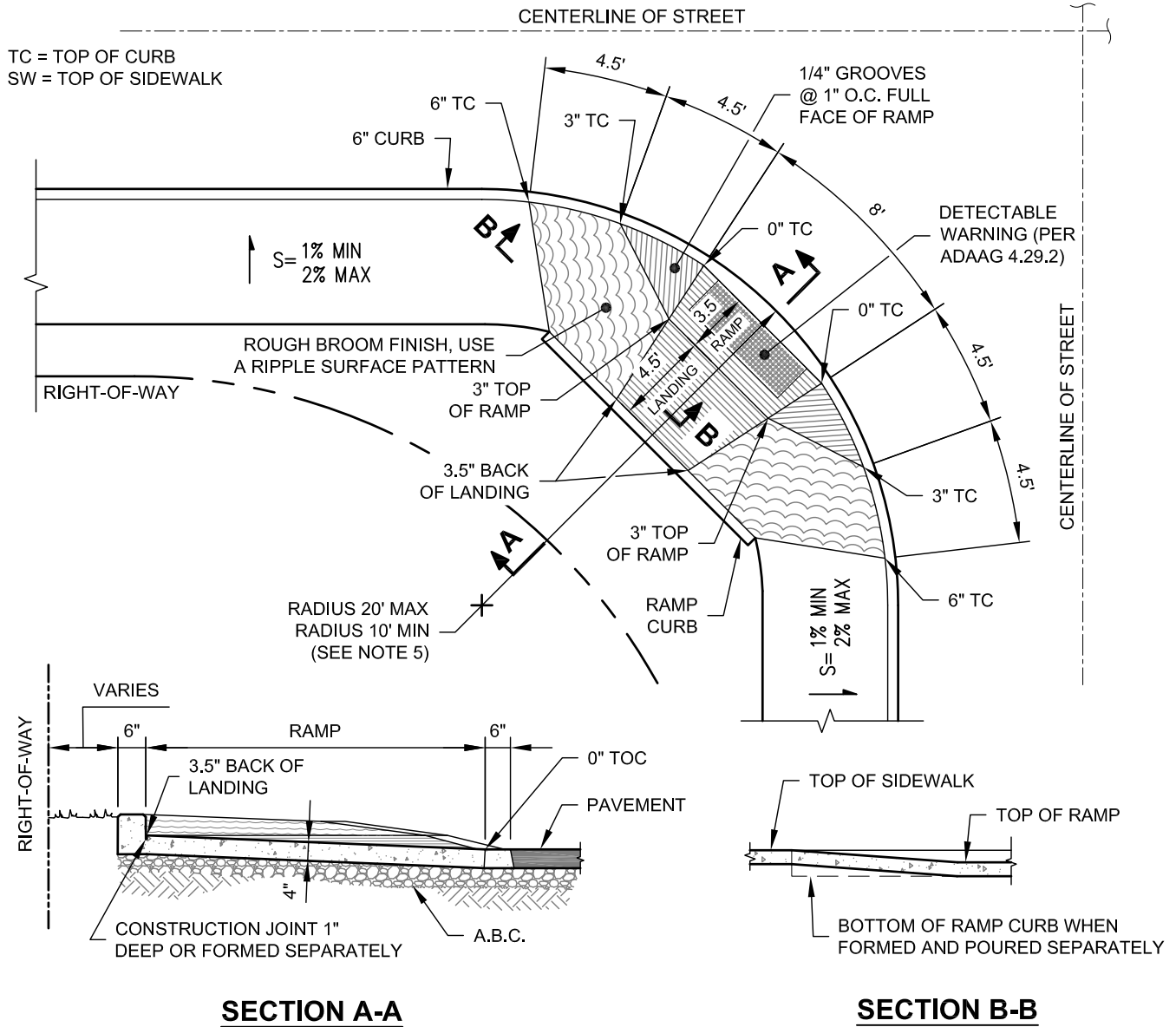

NOTES:

1. REFERENCE MAG DETAIL 231 (MODIFIED).
2. RAMP MUST HAVE GROOVE SLOPING RAMP FACE. GROOVES TO BE PERPENDICULAR TO DIRECTION OF TRAVEL.
3. CENTER OF ACCESSIBLE RAMP TO BE ORIENTED 45° TO THE CENTERLINE OF STREET.
4. CONCRETE STRUCTURES IN RIGHT-OF-WAY SHALL BE A 6 SACK PER CUBIC YARD MIX WITH A 4" MAX SLUMP AND BE ABLE TO PASS A 3000 PSI COMPRESSIVE STRENGTH TEST AT 28 DAYS.
5. ALL SIDEWALKS TO BE 4" THICK CONCRETE.
6. ACCESSIBLE RAMP RADIUS TO BE 10' MIN TO 20' MAX UNLESS OTHERWISE RECOMMENDED IN A TRAFFIC REPORT APPROVED BY THE CITY.
7. NO COLORED CONCRETE IN RIGHT-OF-WAY UNLESS APPROVED BY LAKE HAVASU CITY.
8. NO REBAR OR WIRE MESH IN RIGHT-OF-WAY.
9. CONTROL ELEVATIONS SHOWN ARE IN RELATION TO TOP OF CURB AT 0" OR 6" FOR TOC AND ARE LOCATED RADIALLY.
10. SIDEWALK CROSS-SLOPE (BACK OF SIDEWALK TO CURB) TO BE 1% MIN / 2% MAX.

	Standard Details	Accessible Ramp Street/Street Intersections	Scale: <u>N.T.S.</u>
	Roadway Improvements		Detail No. 207

TC = TOP OF CURB
 SW = TOP OF SIDEWALK

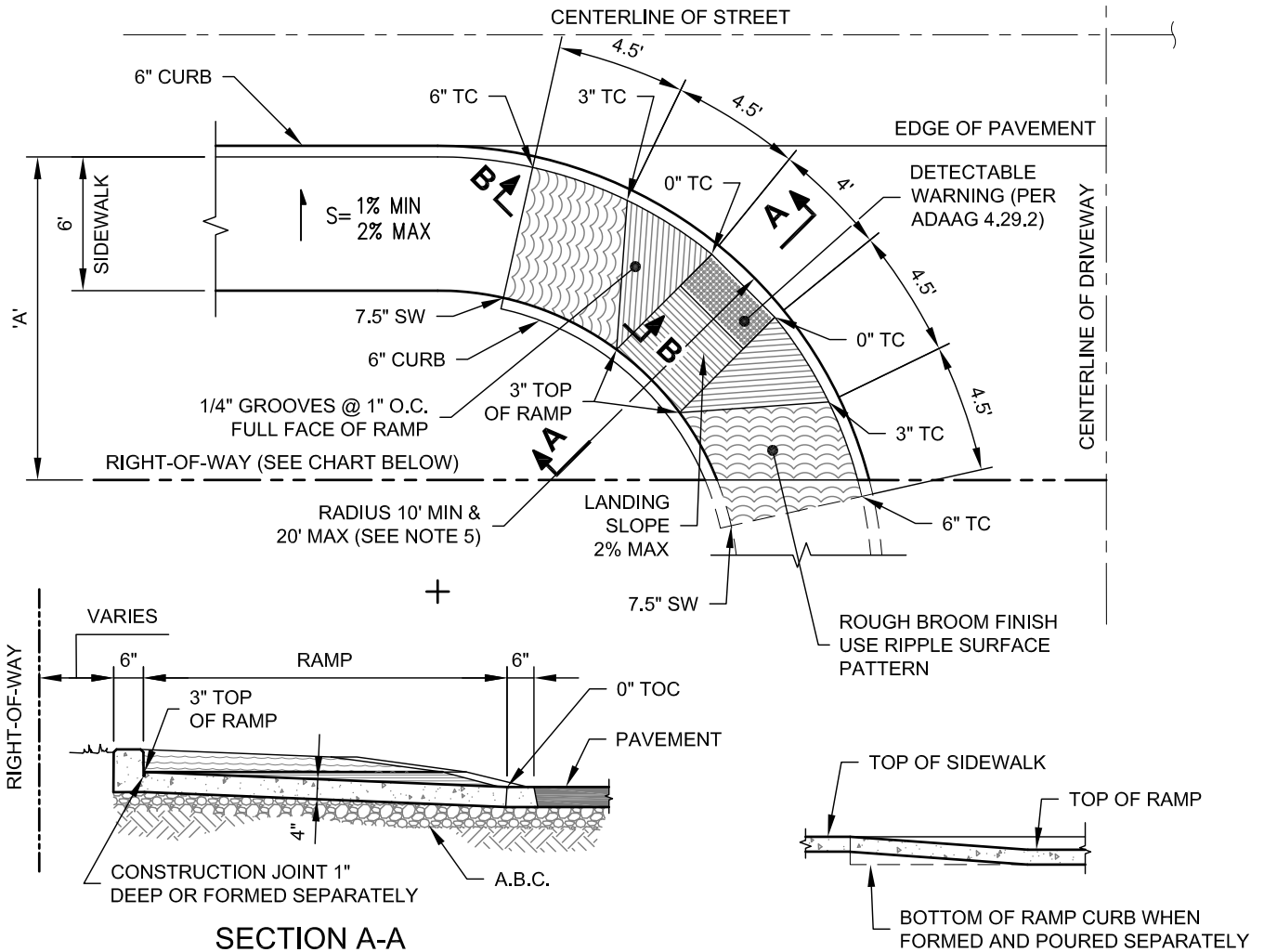

SECTION A-A

SECTION B-B

NOTES:

1. REFERENCE MAG DETAIL 232 (MODIFIED).
2. RAMP MUST HAVE GROOVE SLOPING RAMP FACE. GROOVES TO BE PERPENDICULAR TO DIRECTION OF TRAVEL.
3. CENTER OF ACCESSIBLE RAMP TO BE ORIENTED 45° TO THE CENTERLINE OF STREET.
4. CONCRETE STRUCTURES IN RIGHT-OF-WAY SHALL BE A 6 SACK PER CUBIC YARD MIX WITH A 4" MAX SLUMP AND BE ABLE TO PASS A 3000 PSI COMPRESSIVE STRENGTH TEST AT 28 DAYS.
5. ALL SIDEWALKS TO BE 4" THICK CONCRETE.
6. ACCESSIBLE RAMP RADIUS TO BE 10' MIN TO 20' MAX UNLESS OTHERWISE RECOMMENDED IN A TRAFFIC REPORT APPROVED BY LAKE HAVASU CITY.
7. NO COLORED CONCRETE IN RIGHT-OF-WAY UNLESS APPROVED BY LAKE HAVASU CITY.
8. NO REBAR OR WIRE MESH IN RIGHT-OF-WAY.
9. CONTROL ELEVATIONS SHOWN ARE IN RELATION TO TOP OF CURB AT 0" OR 6" FOR TOP OF CURB AND ARE LOCATED RADIALLY.
10. SIDEWALK CROSS-SLOPE (BACK OF SIDEWALK TO CURB) TO BE 1% MIN / 2% MAX.
11. DIMENSION 'A' IS SUBJECT TO CHANGE, DEPENDING ON WIDENING AND SECTION CHANGES.

DIM 'A' - RIGHT OF WAY	
STREET TYPE	WIDTH
BOULEVARD	15 FEET
AVENUE	13 FEET
DRIVE	9 FEET
OTHER	7 FEET



Standard Details
Roadway
Improvements

Accessible Ramp
Street/Driveway
Intersection

Scale: N.T.S.
 Detail No.
208

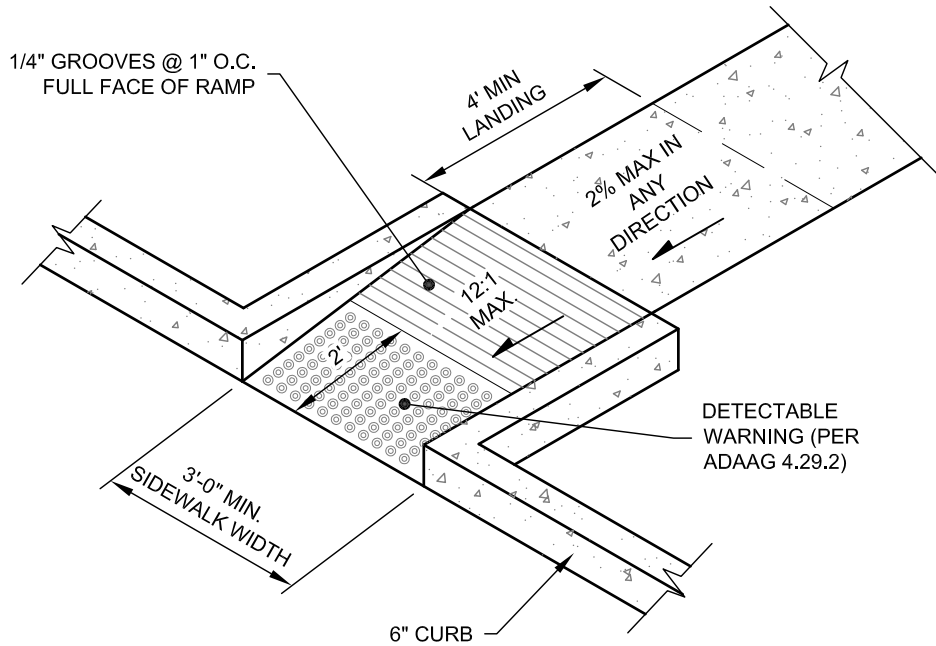

NOTES:

1. RAMP MUST HAVE GROOVE SLOPING RAMP FACE. GROOVES TO BE PERPENDICULAR TO DIRECTION OF TRAVEL.
2. ADAAG 4.29.2 DETECTABLE WARNINGS ON WALKING SURFACES. DETECTABLE WARNINGS SHALL CONSIST OF TRUNCATED DOMES WITH A DIAMETER OF NOMINAL 0.9 IN (23MM), A HEIGHT OF NOMINAL 0.2 IN (5MM) AND A CENTER-TO-CENTER SPACING OF NOMINAL 2.35 IN (60MM) AND SHALL CONTRAST VISUALLY WITH ADJOINING SURFACES, EITHER LIGHT-ON-DARK, OR DARK-ON-LIGHT. THE MATERIAL USED TO PROVIDE CONTRAST SHALL BE AN INTEGRAL PART OF THE WALKING SURFACE. DETECTABLE WARNINGS USED ON INTERIOR SURFACES SHALL DIFFER FROM ADJOINING WALKING SURFACES IN RESILIENCY OR SOUND-ON-CANE CONTACT.
3. INSTALL TRUNCATED DOME MAT AS MANUFACTURED WITH DETECTABLE WARNING SYSTEMS (OR EQUAL) PER MANUFACTURER'S SPECIFICATIONS.

	Standard Details	Accessible Ramp Sidewalk/Street Intersection	Scale: <u>N.T.S.</u>
	Roadway Improvements		Detail No. 210

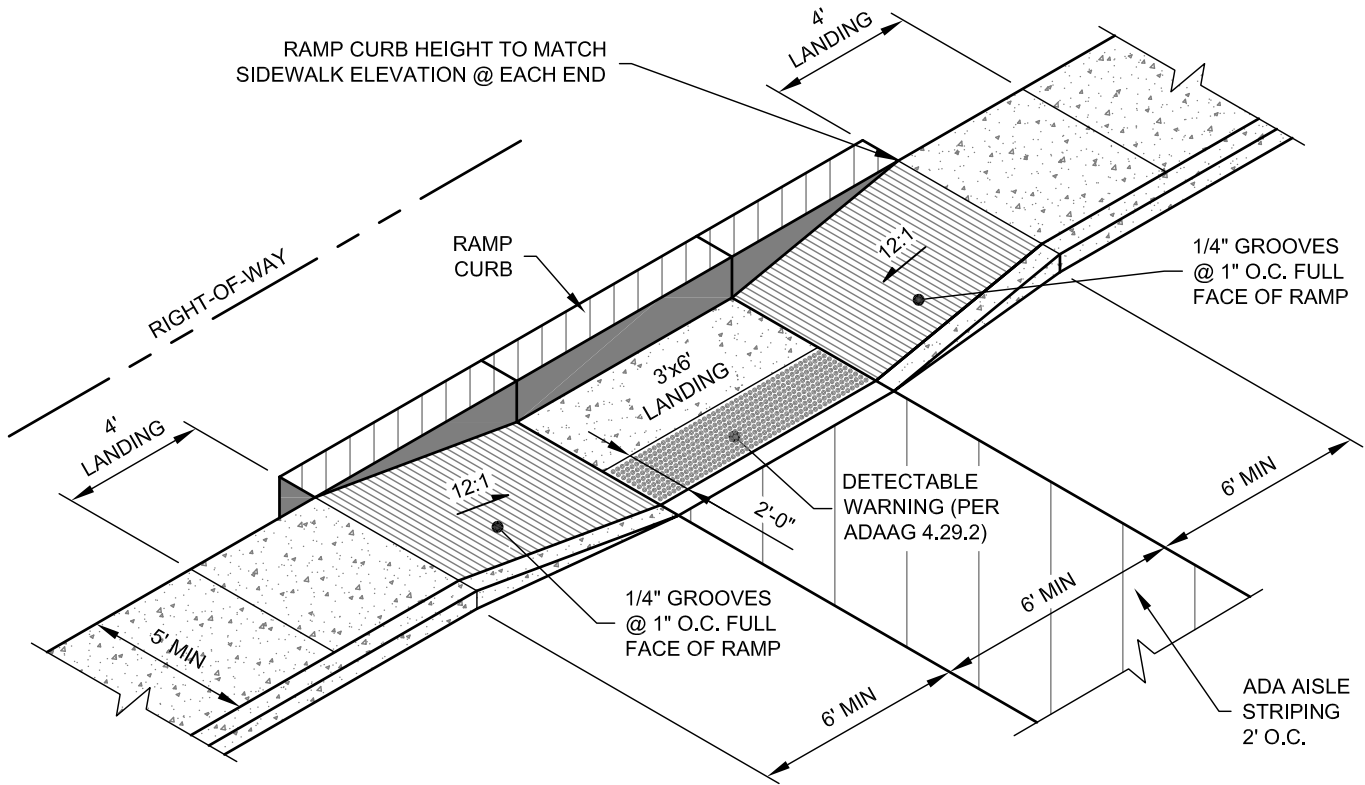

NOTES:

1. RAMP MUST HAVE GROOVE SLOPING RAMP FACE. GROOVES TO BE PERPENDICULAR TO DIRECTION OF TRAVEL.
2. ADAAG 4.29.2 DETECTABLE WARNINGS ON WALKING SURFACES. DETECTABLE WARNINGS SHALL CONSIST OF TRUNCATED DOMES WITH A DIAMETER OF NOMINAL 0.9 IN (23MM), A HEIGHT OF NOMINAL 0.2 IN (5MM) AND A CENTER-TO-CENTER SPACING OF NOMINAL 2.35 IN (60MM) AND SHALL CONTRAST VISUALLY WITH ADJOINING SURFACES, EITHER LIGHT-ON-DARK, OR DARK-ON-LIGHT. THE MATERIAL USED TO PROVIDE CONTRAST SHALL BE AN INTEGRAL PART OF THE WALKING SURFACE. DETECTABLE WARNINGS USED ON INTERIOR SURFACES SHALL DIFFER FROM ADJOINING WALKING SURFACES IN RESILIENCY OR SOUND-ON-CANE CONTACT.
3. INSTALL TRUNCATED DOME MAT AS MANUFACTURED WITH DETECTABLE WARNING SYSTEMS (OR EQUAL) PER MANUFACTURER'S SPECIFICATIONS.

	Standard Details	Parallel Curb Ramp	Scale: <u>N.T.S.</u>
	Roadway Improvements		Detail No. 211

PROVIDE CONTRACTION JOINT AT 10' O.C. MAX.
 CUT WET CONCRETE 2" DEEP WITH TROWEL
 EDGE, FINISH WITH 1/2" EDGING TOOL

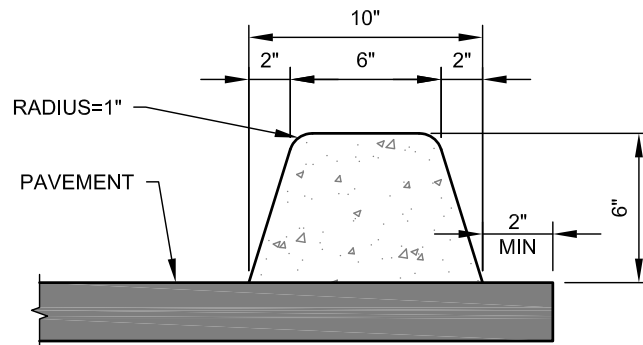
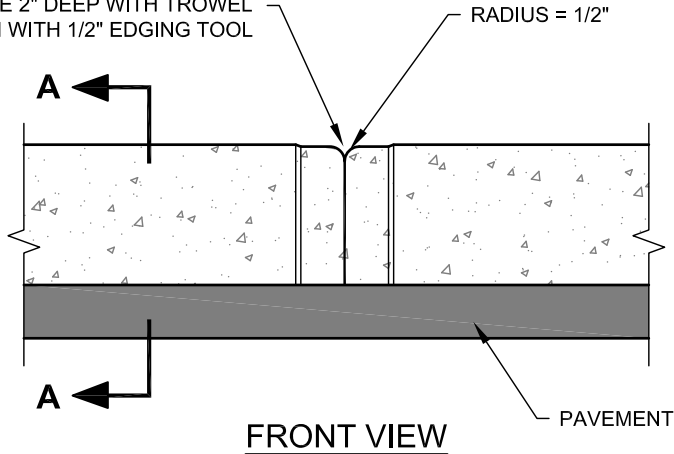

NOTES:

1. TO BE USED FOR REPLACEMENT OF EXISTING EXTRUDED CURBS ONLY.
2. CLASS 'B' CONCRETE 2500 PSI.
3. ALL EXPOSED SURFACES TO BE TROWEL FINISHED.
4. H=6" OR AS SPECIFIED ON PLANS.
5. EXPANSION JOINTS PLACED AT INTERVALS NOT TO EXCEED 100 FEET.

	Standard Details	6" Extruded Vertical Curb	Scale: <u>N.T.S.</u>
	Roadway Improvements		Detail No. 212

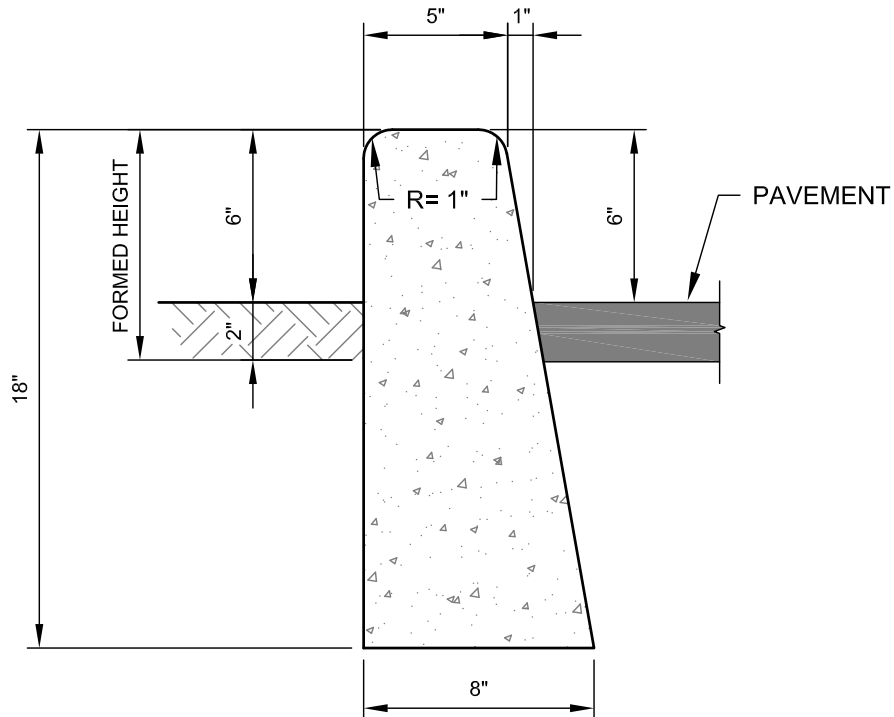

NOTES:

1. ALL VERTICAL SURFACES TO BE FORMED.
2. CLASS 'B' CONCRETE 2500 PSI.
3. ALL EXPOSED SURFACES TO BE TROWEL FINISHED EXCEPT AS SHOWN.
4. CONTRACTION JOINT SPACING 10' MAX.
5. H=6" OR AS SPECIFIED ON PLANS.
6. EXPANSION JOINTS PLACED AT INTERVALS NOT TO EXCEED 100 FEET.

	Standard Details	Vertical Curb	<small>Scale: <u>N.T.S.</u></small>
	Roadway Improvements		Detail No. 213

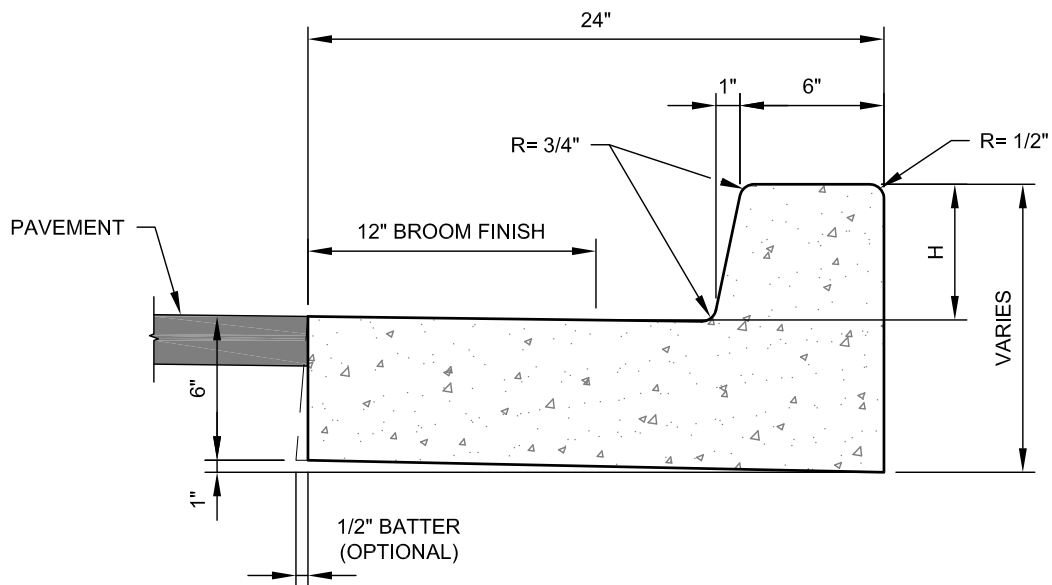

NOTES:

1. CLASS 'B' CONCRETE 2500 PSI.
2. ALL EXPOSED SURFACES TO BE TROWEL FINISHED EXCEPT AS SHOWN.
3. CONTRACTION JOINT SPACING 10' MAX.
4. H=6" OR AS SPECIFIED ON PLANS.
5. EXPANSION JOINTS PLACED AT INTERVALS NOT TO EXCEED 100 FEET.

	Standard Details	Vertical Curb and Gutter	Scale: <u>N.T.S.</u>
	Roadway Improvements		Detail No. 214

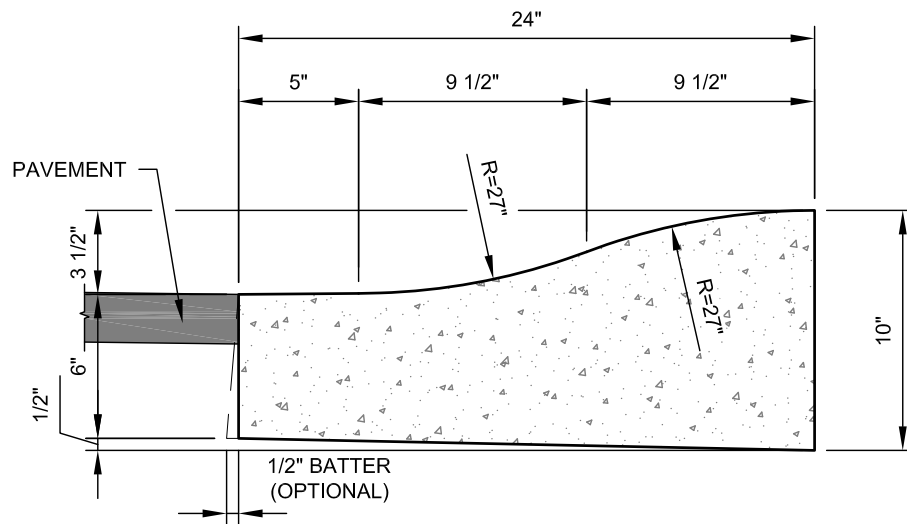

NOTES:

1. MODIFIED MAG 220 (TYPE D).
2. PRIOR APPROVAL FROM ENGINEERING DIVISION REQUIRED.
3. CLASS 'B' CONCRETE 2500 PSI.
4. PLACE 3/4" EXPANSION JOINTS WITH TWO-FOOT DOWELS AT RADIUS POINTS. THESE DOWELS SHALL BE GREASED AND WRAPPED ON ONE END WITH EXPANSION TUBES.
5. INSTALL 1 1/2"-DEEP CONTRACTION JOINTS AT APPROXIMATELY 15' INTERVALS.

	Standard Details	Rolled Curb and Gutter	Scale: <u>N.T.S.</u>
	Roadway Improvements		Detail No. 215

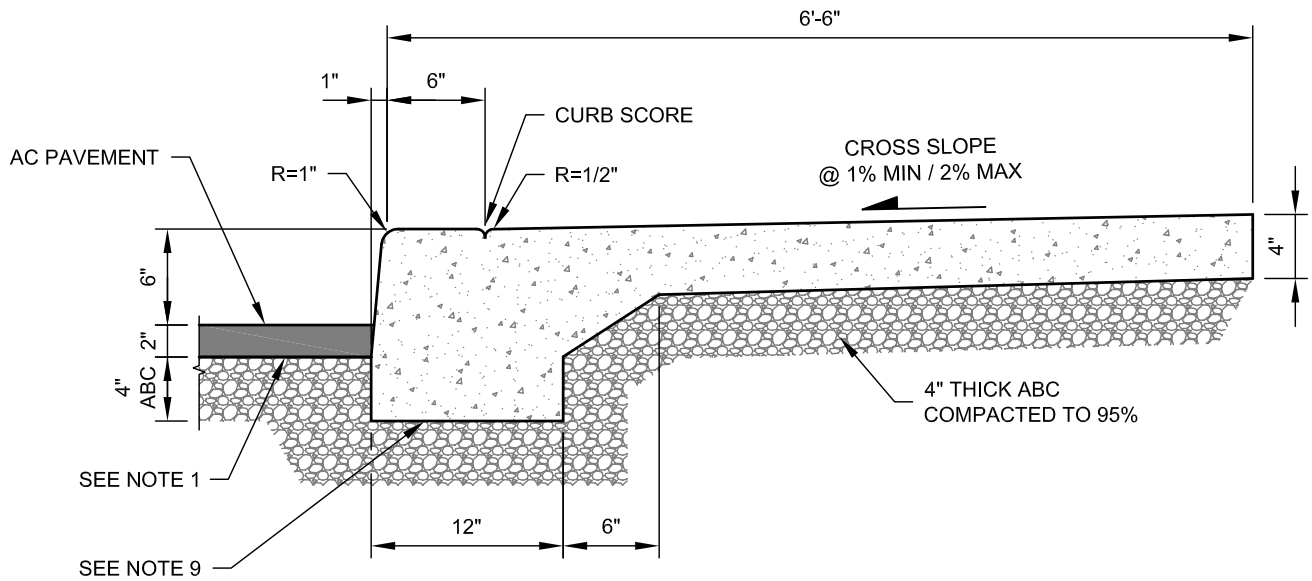

NOTES:

1. FOR NEW INSTALLATION, ASPHALT SHALL BE PLACED AGAINST CONCRETE.
2. CONSTRUCTION JOINTS SHALL BE DEPRESSED ONE INCH.
3. SIDEWALK AND CURB PLACED MONOLITHICALLY.
4. APPROVED CLASS 'A' 3000 PSI CONCRETE.
5. APPROVED CURING PRACTICES, NO DIESEL.
6. EXPANSION JOINTS PLACED AT INTERVALS NOT TO EXCEED 100 FEET.
7. CURB CONTRACTION JOINTS CONSTRUCTED TO DEPTH OF ONE INCH AT 12-FOOT MAX INTERVALS. SIDEWALK CONTRACTION JOINTS REQUIRED AT 6-FOOT INTERVALS.
8. ANY ABOVE-GROUND APPURTENANCE SHALL BE LOCATED OR RELOCATED OUT OF SIDEWALK.
9. BOTTOM OF SIDEWALK CURB SHALL BE PLACED TO SAME SUB-BASE ELEVATION AS ROADWAY.

	Standard Details	Alternate Sidewalk/Curb	Scale: <u>N.T.S.</u>
	Roadway Improvements		Detail No. 216

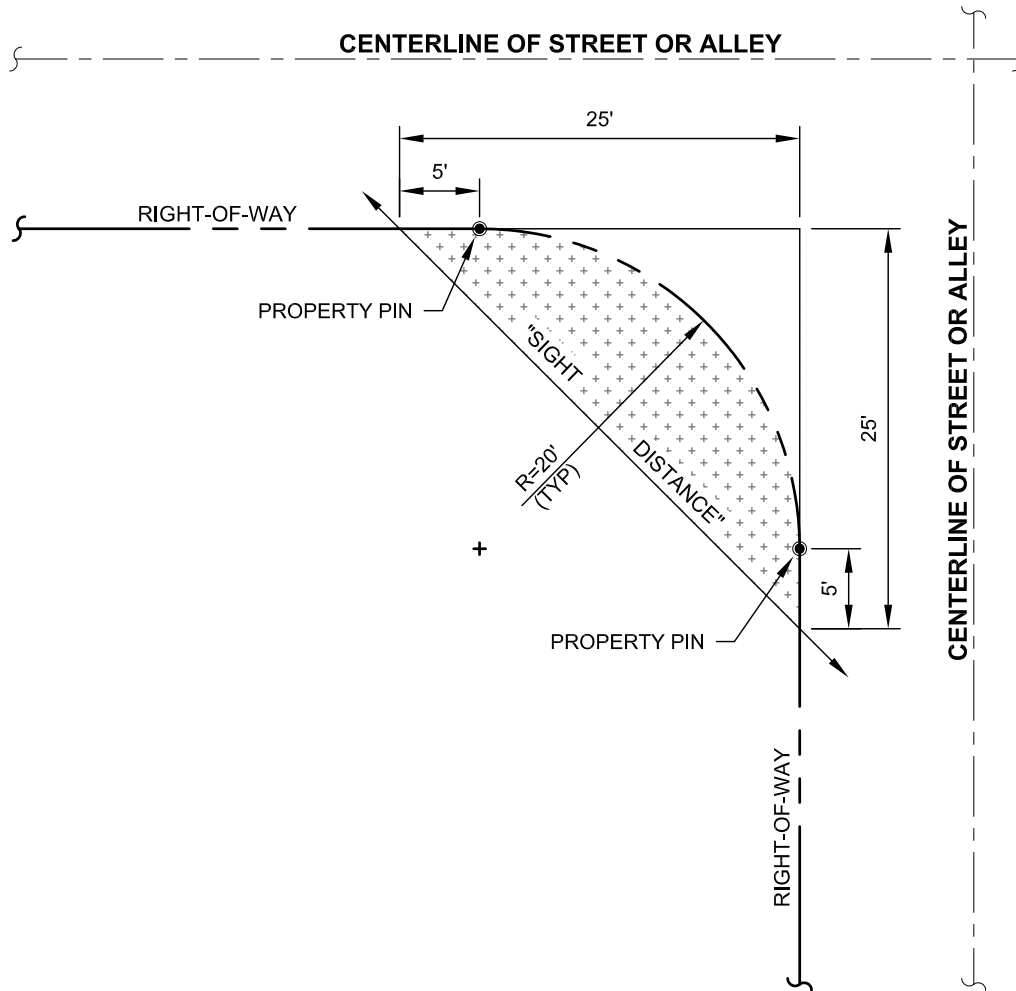

SECTION 14.04-03 D.
 NO CONSTRUCTION INTERFERING WITH SIGHT LINES BETWEEN 2 AND 8 FEET ABOVE THE ELEVATION AT THE PROPERTY LINE.

	Standard Details	Sight Distance Triangle	Scale: <u>N.T.S.</u>
	Roadway Improvements		Detail No. 217

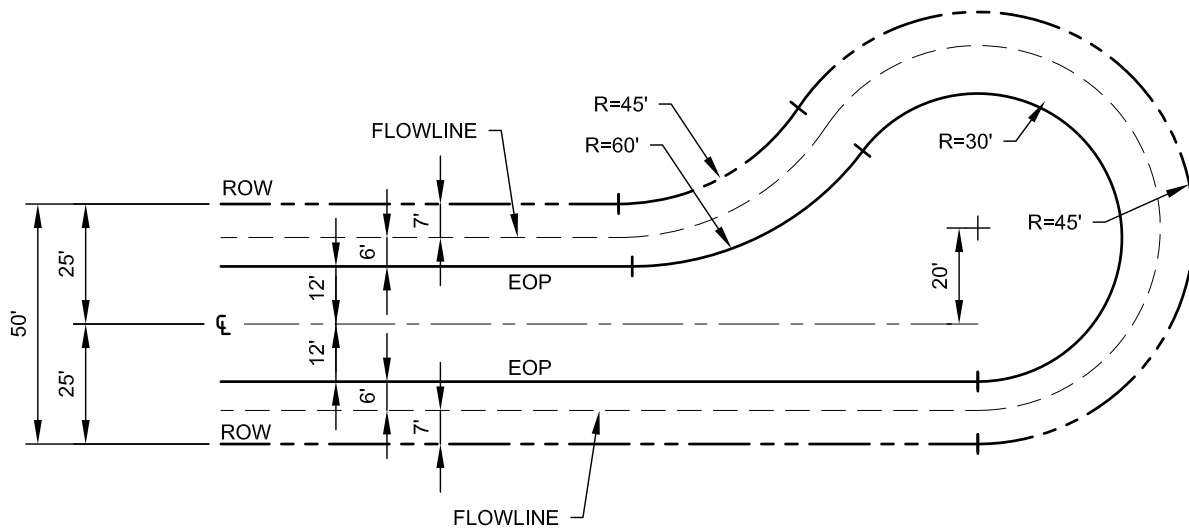
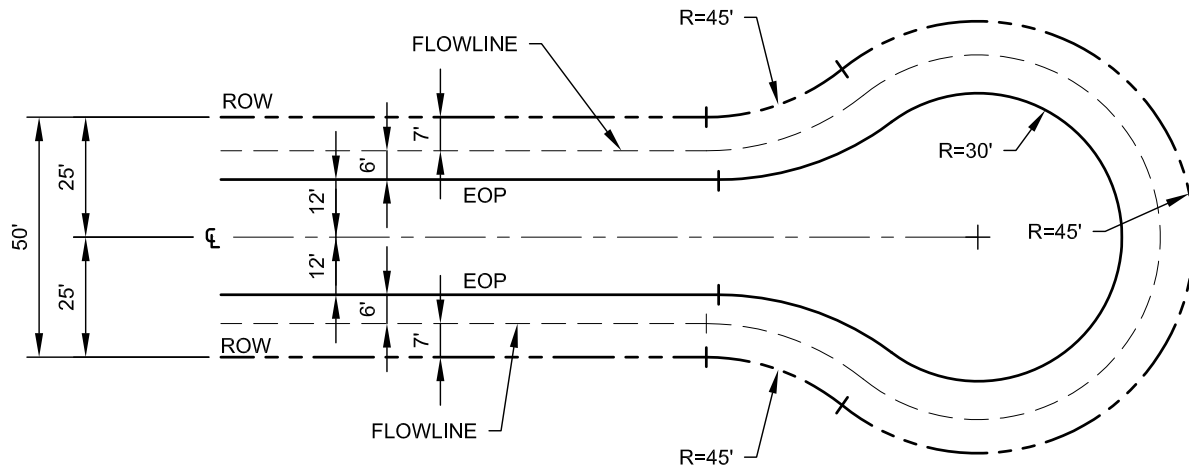

Standard Details
Roadway Improvements

CUL-DE-SAC Pavement

Scale: N.T.S.
Detail No.
218

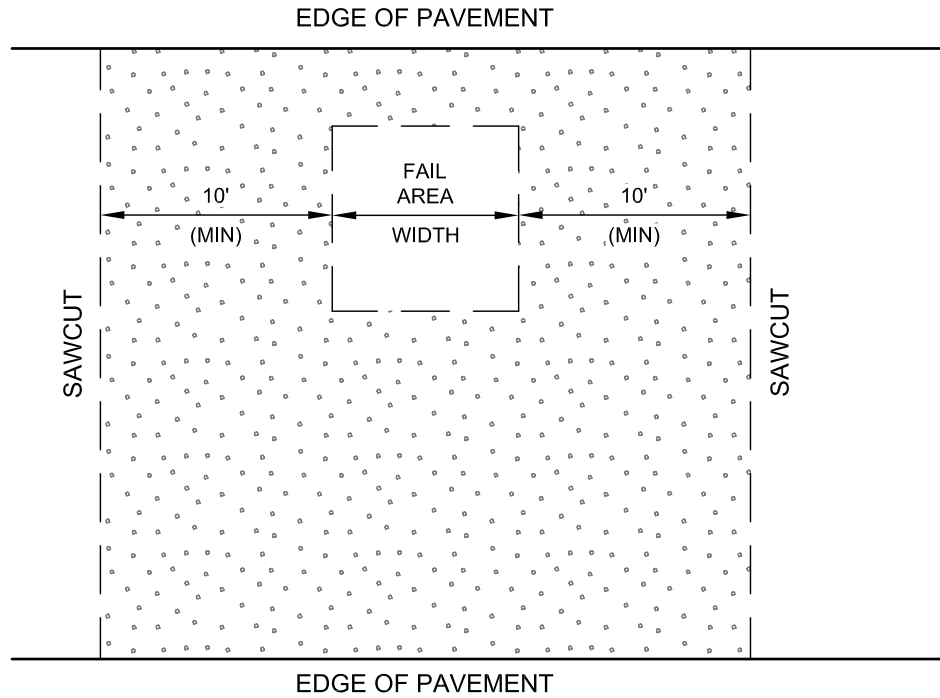

**PAVEMENT REMOVAL AND
REPLACEMENT IN EXISTING STREET**
NOT TO SCALE

NOTES:

1. IN AREAS WHERE PAVEMENT IS CRACKED, POTHOLED, FAILED, OR OTHERWISE PARTIALLY REMOVED, CONTRACTOR SHALL REPLACE PAVEMENT TO 10' EITHER SIDE OF LIMIT OF AREA. FOR THE FULL WIDTH OF THE STREET.

	Standard Details	AC Patch	Scale: <u>N.T.S.</u>
	Roadway Improvements		Detail No. 219

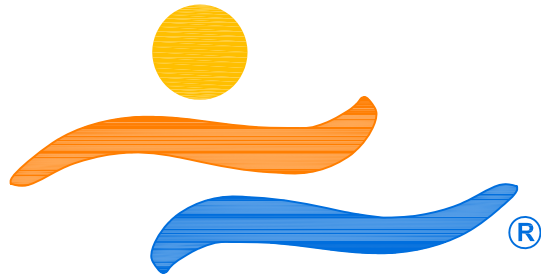

LAKE HAVASU CITY

**WATER
IMPROVEMENTS**

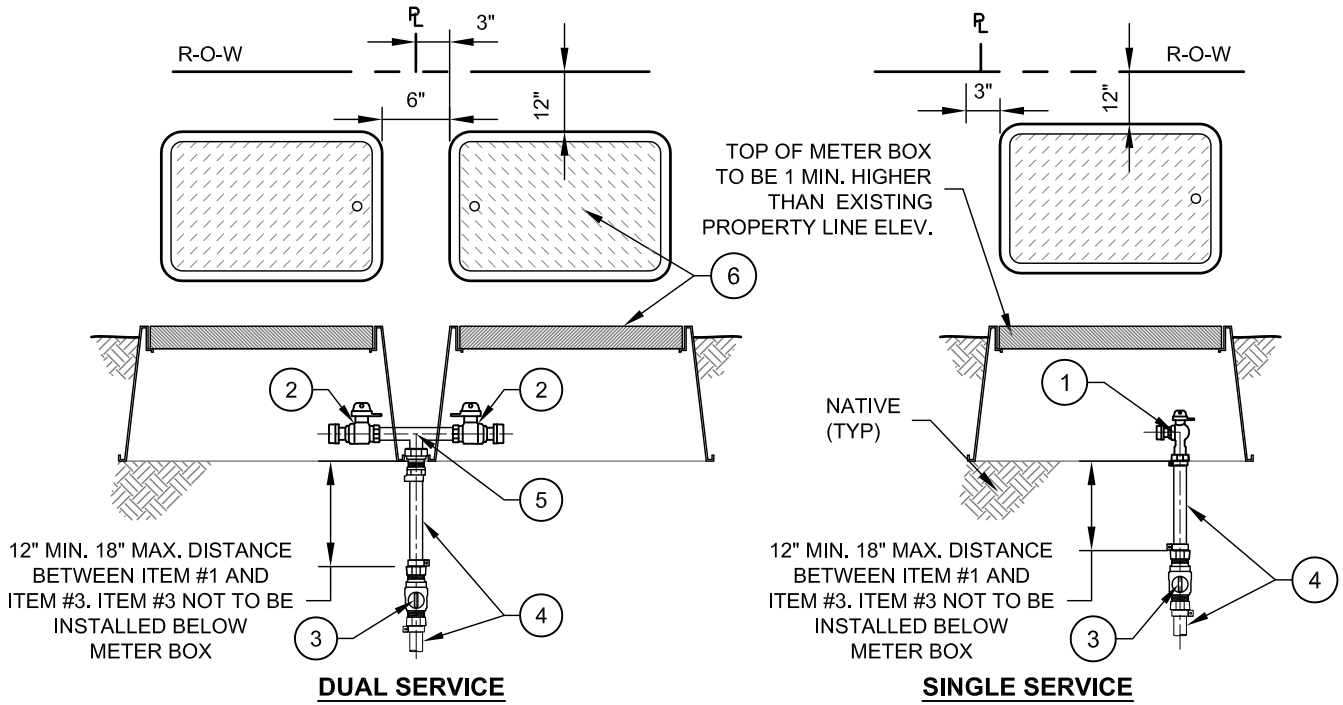

SERVICE TERMINATION DETAIL TABLE			
ITEM NO.	SIZE AND DESCRIPTION	MATERIAL SPECIFICATIONS	REMARKS
①	1" ANGLE METER STOP	FORD BA43-342W-NL	OR EQUAL
②	1" BALL METER VALVE	FORD B13-332W-NL	OR EQUAL
③	1" CURB STOP	FORD B44-444-NL	OR EQUAL
④	1" x REQUIRED LENGTH	COPPER TUBE TYPE "K"	OR EQUAL
⑤	1" SERVICE TEE	FORD T884-334-9-NL	OR EQUAL
⑥	METER BOX	CARSON METER BOX 1220 (25 3/8"x19"x12") TRAFFIC RATED BOX USE CHRISTY MAG 2 (25 1/2"x 17 3/4"x12")	OR EQUAL

SERVICE TERMINATION DETAILS

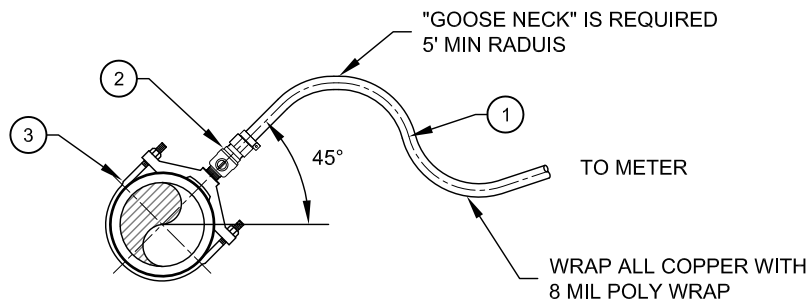

SERVICE CONNECTION DETAIL TABLE			
ITEM NO.	SIZE AND DESCRIPTION	MATERIAL SPECIFICATIONS	REMARKS
①	1" x REQUIRED LENGTH	COPPER TUBE TYPE "K"	OR EQUAL
②	1" CORP STOP	FORD 1" FB1100-4-NL	OR EQUAL
③	1" x MAIN SIZE BRASS STRAP SADDLE	FORD 202B-xxx-IP4 (AC) OR S91-xx4 (C900) SADDLE W/ 1" IP THREAD	OR EQUAL

SERVICE CONNECTION DETAILS

	Standard Details	1" Service Connection	Scale: <u>N.T.S.</u>
	Water Improvements		Detail No. 301

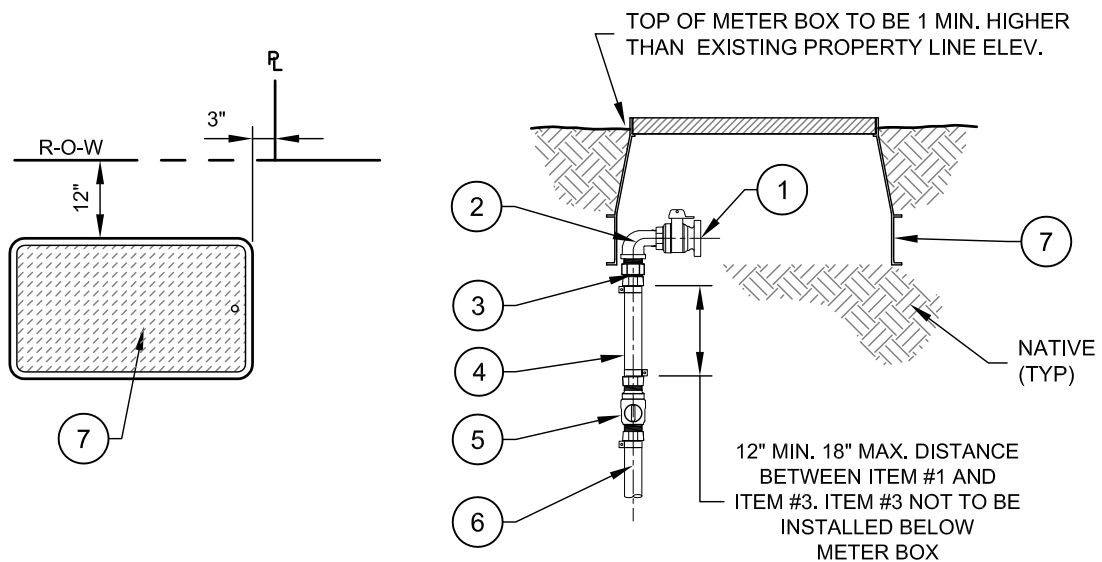

SERVICE TERMINATION DETAIL TABLE			
ITEM NO.	SIZE AND DESCRIPTION	MATERIAL SPECIFICATIONS	REMARKS
①	2" BALL METER VALVE	FORD BF13-777W-NL	OR EQUAL
②	2" 90 STREET ELL	BRASS STREET ELL	
③	2" PACK JOINT COUPLING	2" FORD C84-77-NL	OR EQUAL
④	2" COPPER TUBE	TYPE - "K" COPPER 12" TO 18" LONG	
⑤	2" CURB STOP	FORD B44-777-NL	OR EQUAL
⑥	2" POLY TUBE	POLYETHYLENE PLASTIC TUBING (CTS) (200 PSI)	
⑦	METER BOX	CHRISTY FL36 METER BOX (37"x24"x18 7/16") TRAFFIC RATED BOX USE CHRISTY MAG 2 (25 1/2"x 17 3/4"x12")	OR EQUAL

SERVICE TERMINATION DETAILS

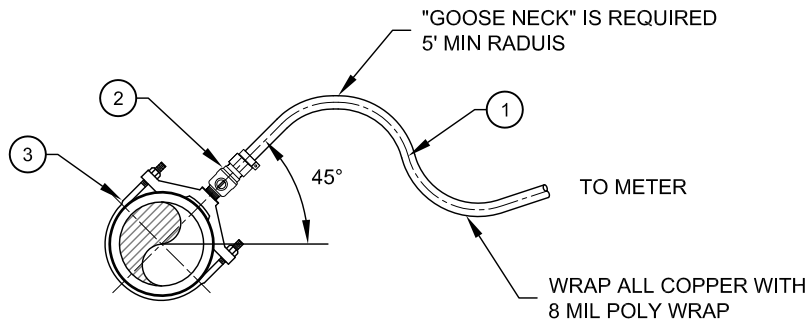

SERVICE TERMINATION DETAIL TABLE			
ITEM NO.	SIZE AND DESCRIPTION	MATERIAL SPECIFICATIONS	REMARKS
①	2" x REQUIRED LENGTH	POLYETHYLENE PLASTIC TUBING (CTS) (200 PSI)	
②	2" CORP STOP	FORD FB1100-7-NL	OR EQUAL
③	2" x MAIN SIZE BRASS SADDLE	FORD 202B-xxx-IP7 (AC) OR S91-xx7 (C900) SADDLE W/ 2" IP THREAD	OR EQUAL

SERVICE CONNECTION DETAILS

	Standard Details	2" Service Connection	Scale: <u>N.T.S.</u>
	Water Improvements		Detail No. 302

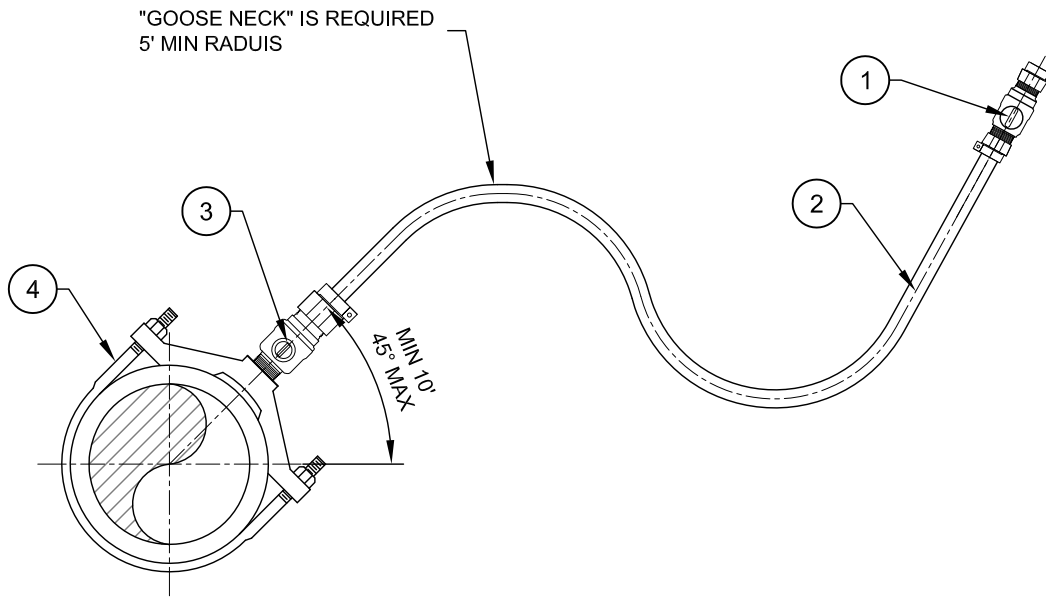

SERVICE TAP

SERVICE TAP DETAIL TABLE			
ITEM NO.	SIZE AND DESCRIPTION	MATERIAL SPECIFICATIONS	REMARKS
①	1" CURB STOP	FORD B44-444-NL	OR EQUAL
②	1" COPPER TUBE	TYPE - "K" SOFT COPPER	
③	1" CORP STOP	FORD FB1100-4-NL	OR EQUAL
④	1" x MAIN SIZE BRASS SADDLE	FORD 202B-xxx-IP4 (AC) OR S91-xx4 (C900) SADDLE W/ 1" IP THREAD	OR EQUAL

NOTE:

1. ALL PARTS ARE FROM FORD METER BOX COMPANY, EXCEPT THE COPPER PIPING.
2. ALL COPPER PIPE ENDS SHALL BE ROUNDED WITH A COPPER ROUNING TOOL AND SHALL BE REAMED WITH A COPPER REAMING TOOL.
3. ALL COPPER TUBING WILL BE SLEEVED WITH MINIMUM 8 MIL. POLYWRAP.
4. ALL ASSEMBLIES TO BE LOCATED WITHIN CITY RIGHT-OF-WAY.

	Standard Details	1" Service Tap	Scale: <u>N.T.S.</u>
	Water Improvements		Detail No. 303

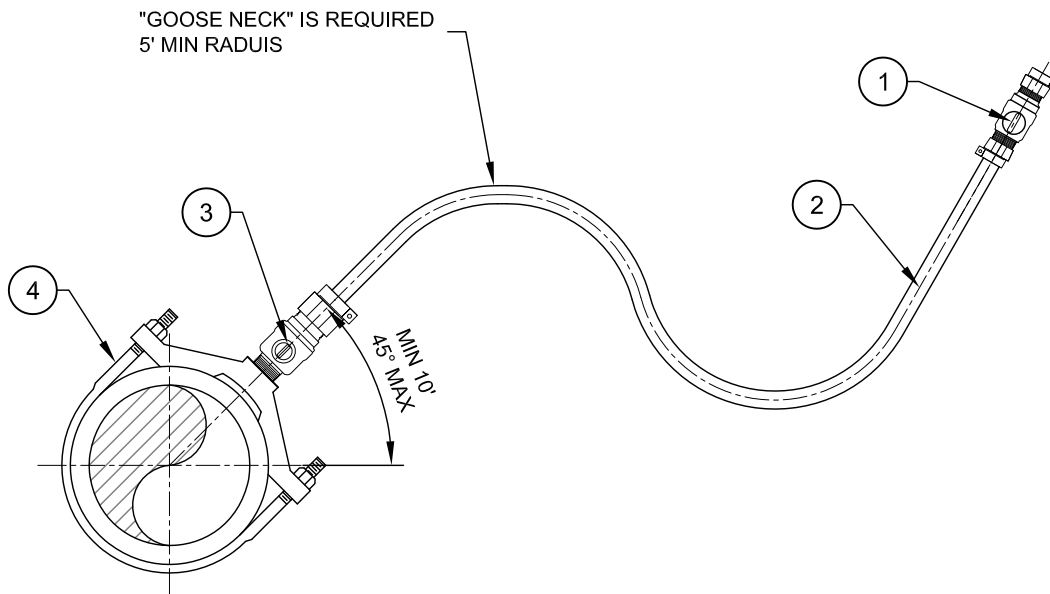

SERVICE TERMINATION DETAIL TABLE

ITEM NO.	SIZE AND DESCRIPTION	MATERIAL SPECIFICATIONS	REMARKS
①	1.5" or 2" CURB STOP	FORD 1.5" B44-666-NL - 2" B44-777-NL	OR EQUAL
②	1.5" or 2" POLY TUBING	POLYETHYLENE PLASTIC TUBING (CTS)(200 PSI) STAINLESS STEEL INSERTS MUST BE USED (1.5" FORD INSERT #54)(2" FORD INSERT #55)	
③	1.5" or 2" CORP STOP	FORD 1.5" FB1100-6-NL - 2" FB1100-7-NL	OR EQUAL
④	1.5" or 2" x MAIN SIZE BRASS SADDLE	FORD 202B-xxx-IP6 (AC) OR S91-xx6 (C900) SADDLE WITH IP THREAD FORD 202B-xxx-IP7 (AC) OR S91-xx7 (C900) SADDLE WITH IP THREAD	OR EQUAL

NOTE:

1. ALL PARTS ARE FROM FORD METER BOX COMPANY, EXCEPT THE COPPER PIPING.
2. ALL ASSEMBLIES TO BE LOCATED WITHIN CITY RIGHT-OF-WAY.

	Standard Details	1.5" - 2" Single Service Tap	Scale: <u>N.T.S.</u>
	Water Improvements		Detail No. 304

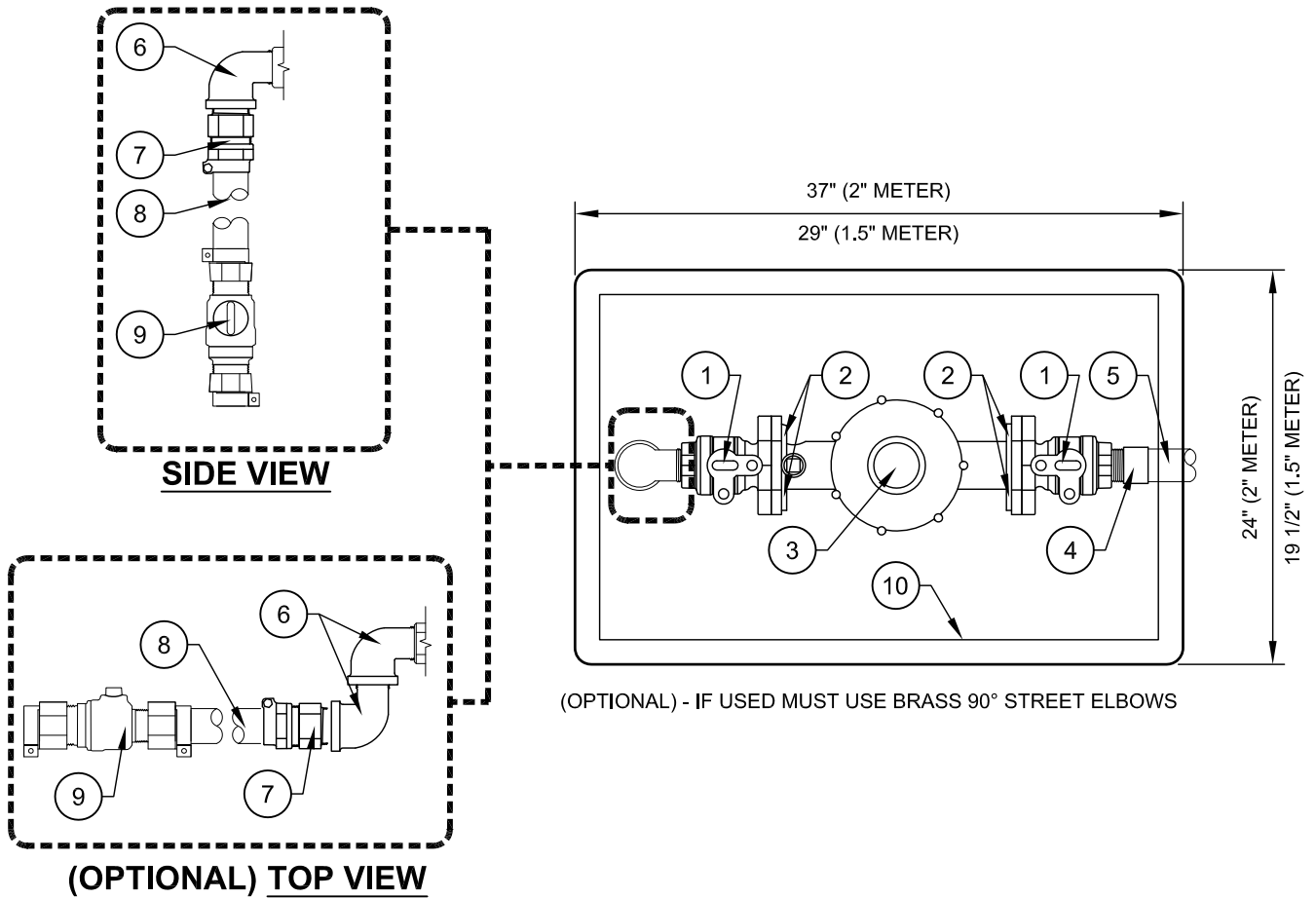

SERVICE METER DETAIL TABLE			
ITEM NO.	SIZE AND DESCRIPTION	MATERIAL SPECIFICATIONS	REMARKS
①	1.5" or 2" BALL METER VALVE	FORD 1.5" BF13-666W-NL - 2" BF13-777W-NL	OR EQUAL
②	BOLTS & NUTS	STAINLESS STEEL	
③	1.5" or 2" WATER METER	BADGER 1.5" M120-150LNSX-HL-GAXX - 2" M170-200LNSX-HL-GAXX	OR EQUAL
④	1.5" or 2" ADAPTOR	FORD C84 PACK JOINT OR PVC MALE ADAPTOR	OR EQUAL
⑤	1.5" or 2" COPPER TUBE/PVC	TYPE - "K" SOFT COPPER OR PVC (COPPER PIPE SHOULD BE USED IF BACKFLOW PREVENTOR ASSEMBLY IS INSTALLED)	
⑥	1.5" or 2" 90° STREET ELBOW	BRASS 90° STREET ELBOW	
⑦	1.5" or 2" PACK JOINT COUPLING	FORD 1.5" C84-66-NL - 2" C84-77-NL	OR EQUAL
⑧	1.5" or 2" POLY TUBING	POLYETHYLENE PLASTIC TUBING (CTS)(200 PSI) STAINLESS STEEL INSERTS MUST BE USED (1.5" FORD INSERT #54)(2" FORD INSERT #55)	
⑨	1.5" or 2" BALL CURB VALVE	FORD 1.5" B44-666-NL - 2" B44-777-NL	OR EQUAL
⑩	METER BOX	CHRISTY FL36 MODEL 17x30 (37"x24"x18 7/16")	OR EQUAL

NOTES:

1. COMMERCIAL AND IRRIGATION WATER METERS REQUIRE APPROVED BACKFLOW PREVENTED ASSEMBLIES PER LAKE HAVASU CITY SPECIFICATIONS.

	<p>Standard Details</p>	<p>1.5" & 2" Water Meter Assembly</p>	<p>Scale: <u>N.T.S.</u></p>
	<p>Water Improvements</p>		<p>Detail No.</p> <p>305</p>

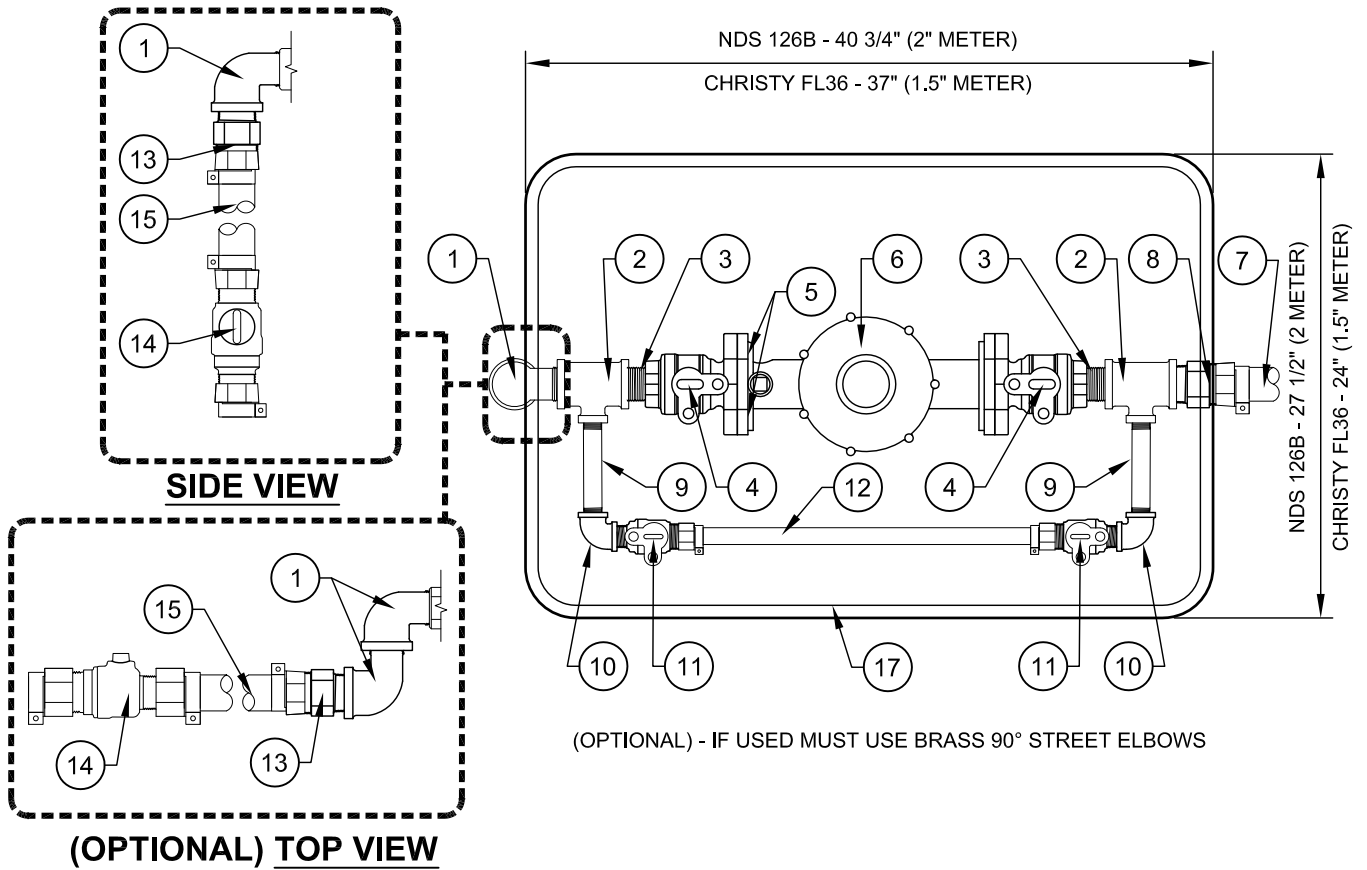

SERVICE METER DETAIL TABLE			
ITEM NO.	SIZE AND DESCRIPTION	MATERIAL SPECIFICATIONS	REMARKS
①	1.5" or 2" 90°	BRASS 90° STREET ELBOW	
②	1.5"x1" or 2"x1" TEE	BRASS REDUCING TEE	
③	1.5" or 2" NIPPLE	BRASS NIPPLE (CLOSE)	
④	1.5" or 2" BALL METER VALVE	FORD 1.5" BF13-666W-NL - 2" BF13-777W-NL	OR EQUAL
⑤	BOLTS & NUTS	STAINLESS STEEL	
⑥	1.5" or 2" WATER METER	BADGER 1.5" M120-150LNSX-HL-GAXX - 2" M170-200LNSX-HL-GAXX	
⑦	1.5" or 2" COPPER TUBE/PVC	TYPE - "K" SOFT COPPER OR PVC (COPPER PIPE SHOULD BE USED IF BACKFLOW PREVENTOR ASSEMBLY IS INSTALLED)	
⑧	1.5" or 2" ADAPTOR	FORD C84 PACK JOINT OR PVC MALE ADAPTOR	
⑨	1" NIPPLE	BRASS 6" NIPPLE	
⑩	1" 90° ELBOW	BRASS 90° ELBOW	
⑪	1" CURB STOP	FORD 1" B84-444W-NL	OR EQUAL
⑫	1" POLY TUBING	POLYETHYLENE PLASTIC TUBING (CTS)(200 PSI) STAINLESS STEEL INSERTS MUST BE USED (1" FORD INSERT #52)	
⑬	1.5" or 2" PACK JOINT	FORD 1.5" C84-66-NL - FORD 2" C84-77-NL	OR EQUAL
⑭	1.5" or 2" BALL CURB VALVE	FORD 1.5" B44-666-NL - 2" B44-777-NL	OR EQUAL
⑮	1.5" or 2" POLY TUBING	POLYETHYLENE PLASTIC TUBING (CTS)(200 PSI) STAINLESS STEEL INSERTS MUST BE USED (1.5" FORD INSERT #54)(2" FORD INSERT #55)	
⑯	METER BOX	FOR 1.5" ASSEMBLY CHRISTY FL36 MODEL 17"x30" (37"x24"x18 7/16") FOR 2" ASSEMBLY NDS 126B W/ COVER (40 3/4"x27 1/2"x18")	OR EQUAL

NOTES:

- RESIDENTIAL DOMESTIC WATER METERS REQUIRE CHECK VALVES ON OUTLET SIDE OF METER. COMMERCIAL AND IRRIGATION WATER METERS REQUIRE APPROVED BACKFLOW PREVENTED ASSEMBLIES PER L.H.C. SPECIFICATIONS.

	Standard Details	1.5" & 2" Water Meter Bypass Assembly	Scale: <u>N.T.S.</u>
	Water Improvements		Detail No. 306

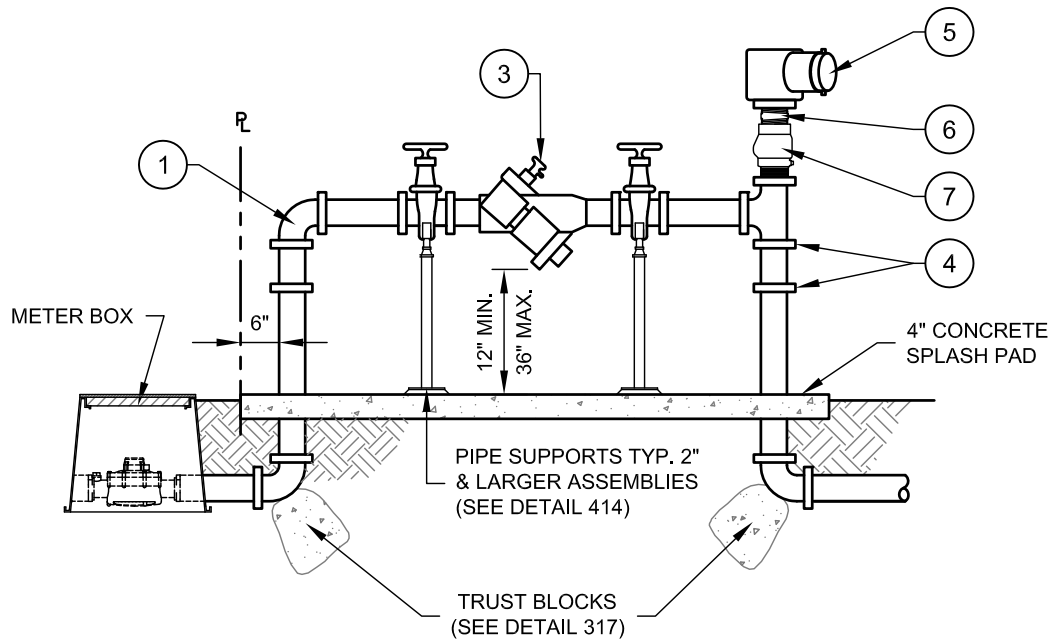
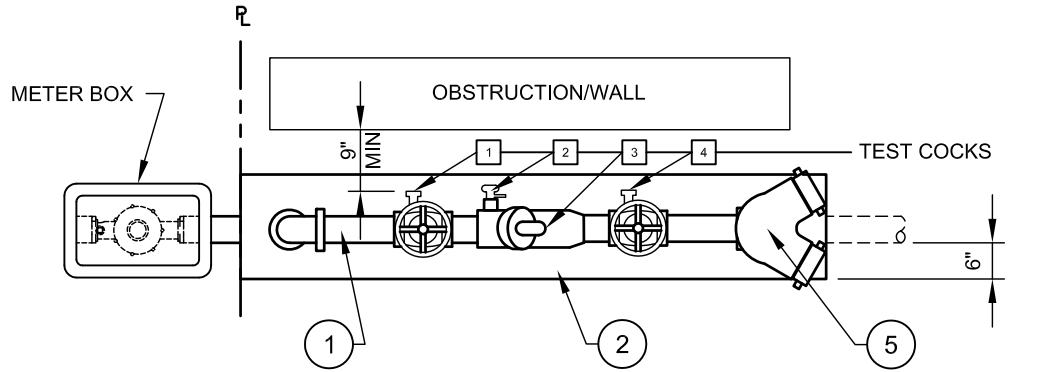

DOUBLE CHECK VALVE DETAIL TABLE

ITEM NO.	SIZE AND DESCRIPTION
①	ALL 2" OR 3" PIPING ABOVE GROUND TO BE BRASS OR COPPER (TYPE K). ASSEMBLIES 4" AND LARGER TO BE DUCTILE IRON.
②	4" THICK CONCRETE PAD TO BE 2500 PSI FOR 1 1/2 INCH ASSEMBLIES AND ABOVE; NOT REQUIRED FOR LESS THAN 1 1/2 INCH ASSEMBLIES.
③	USC-FCCCHR APPROVED ASSEMBLY.
④	UNION/FLANGE REQUIRED FOR REMOVAL.
⑤	FIRE DEPARTMENT CONNECTION DOUBLE SNOOT PER LAKE HAVASU CITY FIRE DEPARTMENT.
⑥	NIPPLE (CLOSE)
⑦	4" CHECK VALVE (UNITED BRASS WORKS MODEL 68)

NOTE: ALL ASSEMBLIES TO BE LOCATED ON PRIVATE PROPERTY.

 LAKE HAVASU CITY	Standard Details	Commercial Double Check Valve Assembly with Fire Dept. Connection	Scale: <u>N.T.S.</u>
	Water Improvements		Detail No. 307

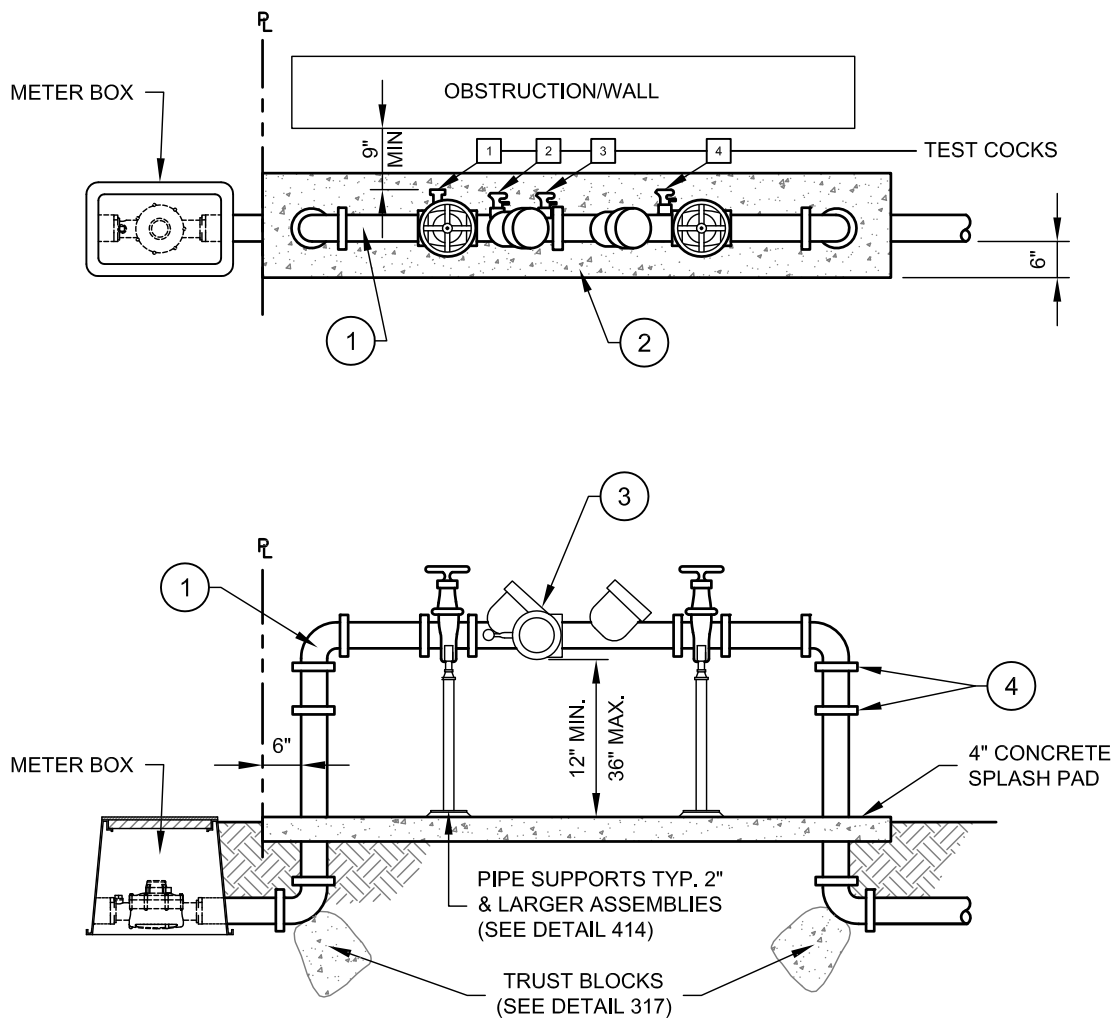

PRESSURE REDUCING ASSEMBLY DETAIL TABLE

ITEM NO.	SIZE AND DESCRIPTION
①	ALL 2" OR 3" PIPING ABOVE GROUND TO BE BRASS OR COPPER (TYPE K). ASSEMBLIES 4" AND LARGER TO BE DUCTILE IRON.
②	4" THICK CONCRETE PAD TO BE 2500 PSI FOR 1/2 INCH ASSEMBLIES AND ABOVE; NOT REQUIRED FOR LESS THAN 1/2 INCH ASSEMBLIES.
③	USC-FCCCHR APPROVED ASSEMBLY.
④	UNION/FLANGE REQUIRED FOR REMOVAL.

NOTE: ALL ASSEMBLIES TO BE LOCATED ON PRIVATE PROPERTY.

	Standard Details	Pressure Reducing Assembly	Scale: <u>N.T.S.</u>
	Water Improvements		Detail No. 308

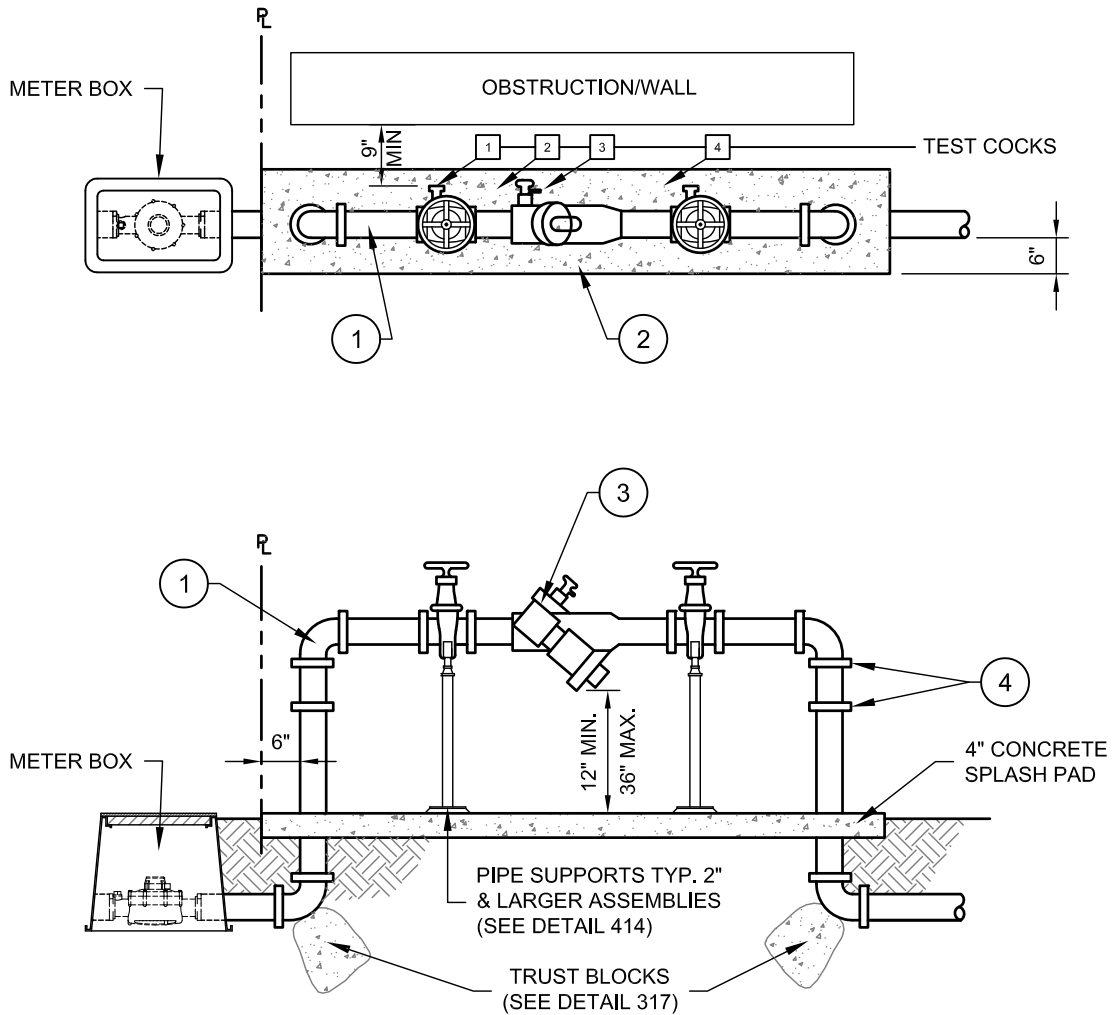

PRESSURE REDUCING ASSEMBLY DETAIL TABLE

ITEM NO.	SIZE AND DESCRIPTION
①	ALL 2" OR 3" PIPING ABOVE GROUND TO BE BRASS OR COPPER (TYPE K). ASSEMBLIES 4" AND LARGER TO BE DUCTILE IRON.
②	4" THICK CONCRETE PAD TO BE 2500 PSI FOR 1/2 INCH ASSEMBLIES AND ABOVE; NOT REQUIRED FOR LESS THAN 1/2 INCH ASSEMBLIES.
③	USC-FCCCHR APPROVED ASSEMBLY.
④	UNION/FLANGE REQUIRED FOR REMOVAL.

NOTE: ALL ASSEMBLIES TO BE LOCATED ON PRIVATE PROPERTY.



Standard Details

Water Improvements

Double Check Valve Assembly

Scale: N.T.S.

Detail No.

309

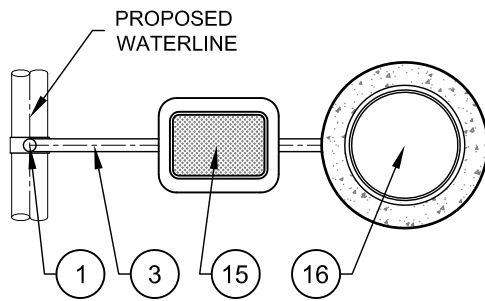

PLAN VIEW

TOP OF VALVE BOX TO BE 1" MIN. HIGHER THAN EXISTING PROPERTY LINE ELEV.
FINISH GRADE

R-O-W

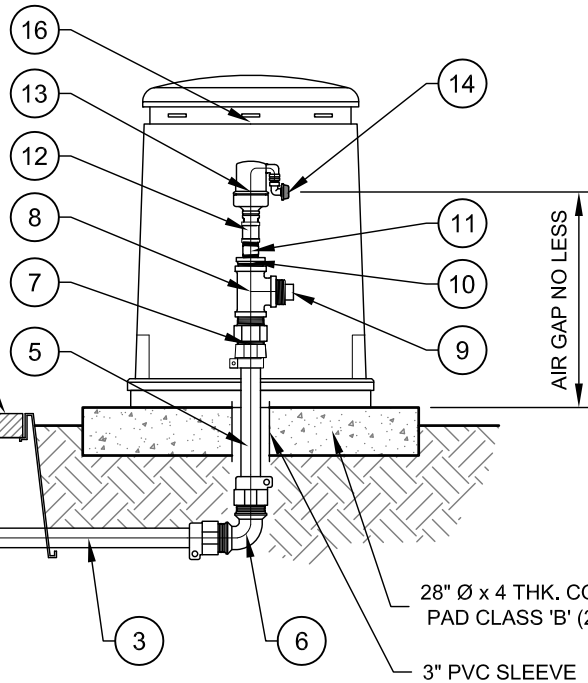

28" Ø x 4 THK. CONCRETE PAD CLASS 'B' (2500 PSI)

3" PVC SLEEVE

NOTE:

1. WRAP ALL COPPER & BRASS WITH 8 MIL POLY WRAP.
2. COMPACT SUB-GRADE UNDER VALVE & ARV ENCLOSURE PAD.
3. IF BLOWOFF IS NOT USED ELIMINATE ITEMS 8 & 9.

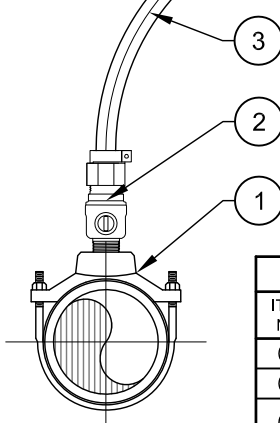

1" COMBINATION AIR/VAC - 2" BLOW OFF DETAIL TABLE

ITEM NO.	SIZE AND DESCRIPTION	MATERIAL SPECIFICATIONS
①	2" x MAIN SIZE BRASS SADDLE	FORD 202B-xxx-IP4 (AC) OR S91-xx4 (C900) SADDLE WITH IP THREAD
②	2" CORP STOP	FORD FB1100-7-NL
③	2" POLY TUBING	POLYETHYLENE PLASTIC TUBING (CTS)(200 PSI) STAINLESS STEEL INSERTS (2" FORD INSERT #55)
④	2" CURB STOP	FORD B44-777-NL
⑤	2" COPPER TUBE	COPPER TYPE "K" SLEEVED WITH 8 MIL. POLY WRAP
⑥	2" PACK JOINT ELL COUPLING	FORD L44-77-NL
⑦	2" PACK JOINT COUPLING	FORD C84-77-NL
⑧	2" TEE	BRASS TEE
⑨	2" PLUG	BRASS PLUG MIPT
⑩	2"x1" REDUCING BUSHING	BRASS REDUCING BUSHING 2" MIPT x 1" FIPT
⑪	1" NIPPLE	BRASS NIPPLE 1x2
⑫	1" COUPLING	BRASS COUPLING 1" FIPT x FIPT
⑬	1" ARV	ARI D-040 COMBINATION AIR/VACUUM RELEASE VALVE
⑭	3/8" SCREEN	BUG SCREEN 40 MESH
⑮	VALVE BOX	CARSON 1419 VALVE BOX (20 7/8"x15 3/4"x12") TRAFFIC RATED BOX USE CHRISTY MAG 2 (25 1/2"x 17 3/4"x12")
⑯	POLYETHYLENE ENCLOSURE	PIPELINE PRODUCTS ADVANTAGE SERIES ENCLOSURE (VCAS-1830)



Standard Details

Water Improvements

1" Combination Air/Vacuum Valve & 2" Blow-Off

Scale: N.T.S.

Detail No.

310

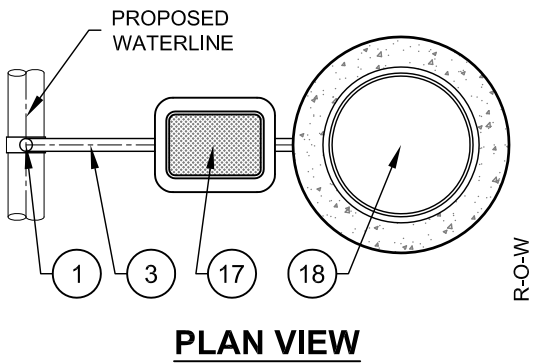

PLAN VIEW

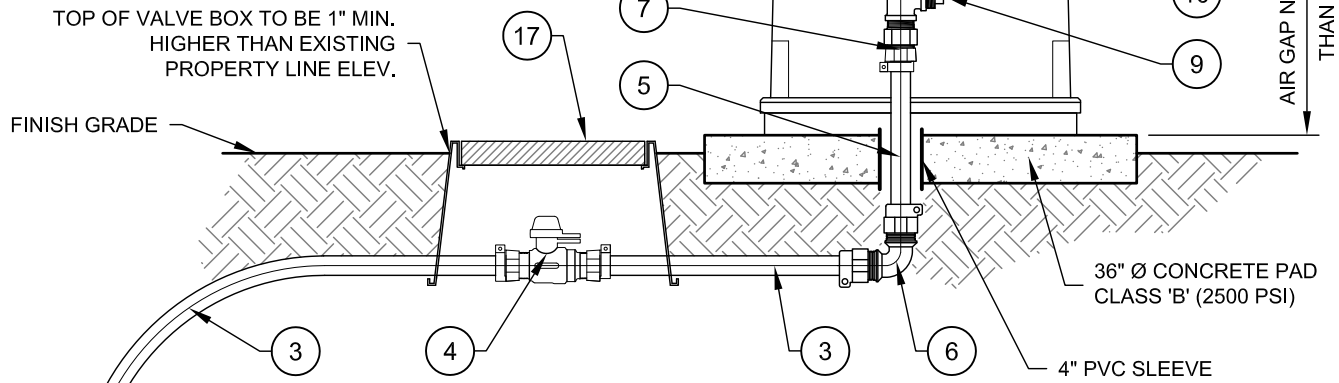

NOTE:

1. WRAP ALL COPPER & BRASS WITH 8 MIL POLY WRAP.
2. COMPACT SUB-GRADE UNDER VALVE PAD & ARV ENCLOSURE PAD.
3. IF BLOWOFF IS NOT REQUIRED USE ENCLOSURE & CONCRETE PAD FROM DETAIL 310 & ELIMINATE ITEMS 8 & 9.

2" COMBINATION AIR/VAC - 2" BLOW OFF DETAIL TABLE

ITEM NO.	SIZE AND DESCRIPTION	MATERIAL SPECIFICATIONS
①	2" x MAIN SIZE BRASS SADDLE	FORD 202B-xxx-IP4 (AC) OR S91-xx4 (C900) SADDLE WITH IP THREAD
②	2" CORP STOP	FORD FB1100-7-NL
③	2" POLY TUBING	POLYETHYLENE PLASTIC TUBING (CTS)(200 PSI) STAINLESS STEEL INSERTS (2" FORD INSERT #55)
④	2" CURB STOP	FORD B44-777-NL
⑤	2" COPPER TUBE	COPPER TYPE "K" SLEEVED WITH 8 MIL. POLY WRAP
⑥	2" PACK JOINT ELL COUPLING	FORD L44-77-NL
⑦	2" PACK JOINT COUPLING	FORD C84-77-NL
⑧	2" TEE	BRASS TEE
⑨	2" PLUG	BRASS PLUG MIPT
⑩	2" NIPPLE	BRASS NIPPLE 2"x4"
⑪	2" COUPLING	BRASS COUPLING FIPT
⑫	2" ARV	ARI D-040 COMBINATION AIR/VACUUM RELEASE VALVE
⑬	1 1/2" NIPPLE	PVC SCH 80 NIPPLE
⑭	1 1/2" 90	PVC SCH 80 90 FIPT x FIPT
⑮	1 1/2"x1" REDUCING BUSHING	PVC SCH 80 REDUCING BUSHING 1 1/2" MIPT x 1" FIPT
⑯	1" SCREEN	BUG SCREEN 40 MESH
⑰	VALVE BOX	CARSON 1419 VALVE BOX (20 7/8"x15 3/4"x12") TRAFFIC RATED BOX USE CHRISTY MAG 2 (25 1/2"x 17 3/4"x12")
⑱	POLYETHYLENE ENCLOSURE	PIPELINE PRODUCTS ADVANTAGE SERIES ENCLOSURE (VCAS-2436)



Standard Details

Water Improvements

2" Combination Air/Vacuum Valve & 2" Blow-Off

Scale: N.T.S.

Detail No.

311

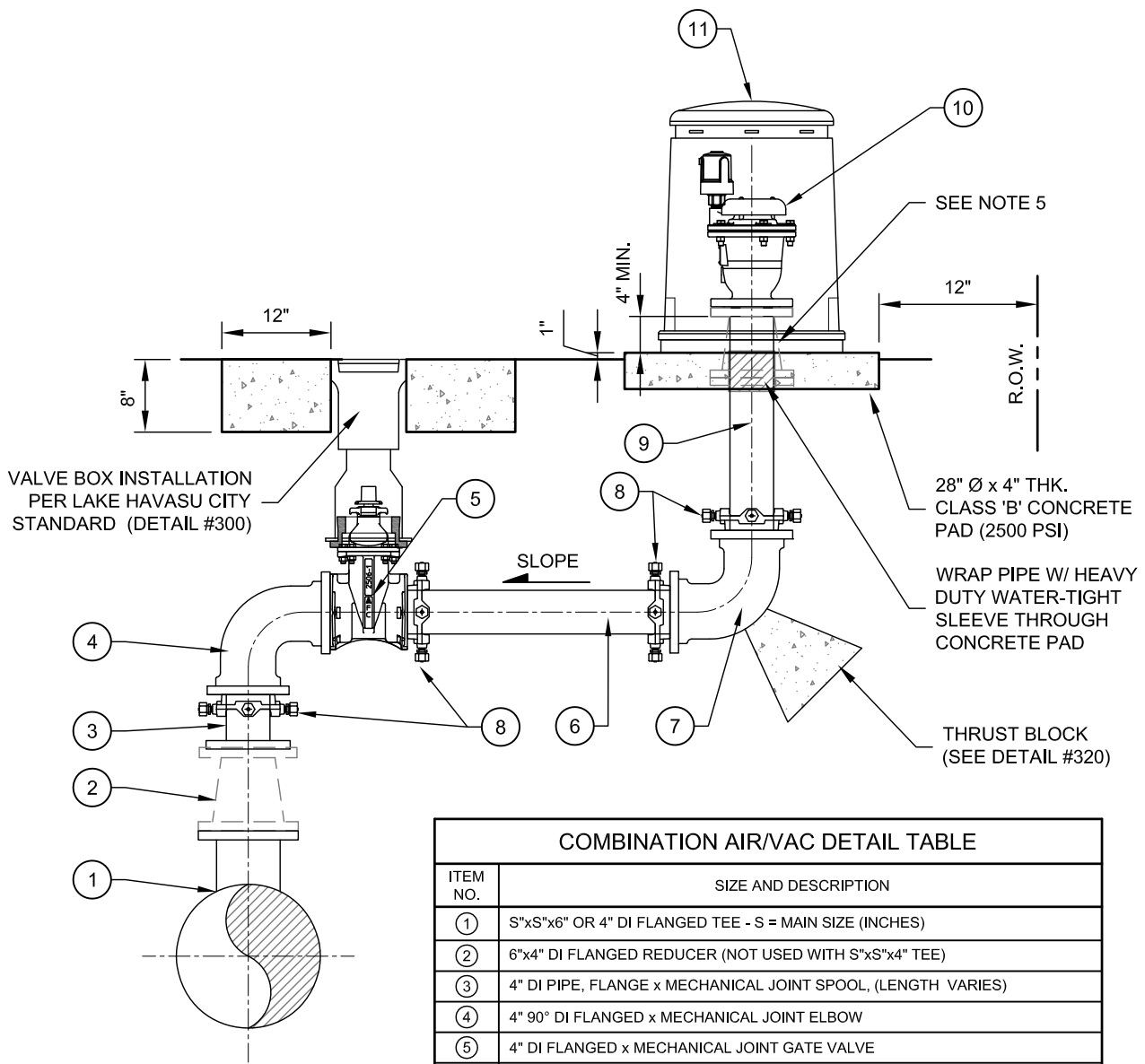

COMBINATION AIR/VAC DETAIL TABLE	
ITEM NO.	SIZE AND DESCRIPTION
①	S"xS"x6" OR 4" DI FLANGED TEE - S = MAIN SIZE (INCHES)
②	6"x4" DI FLANGED REDUCER (NOT USED WITH S"xS"x4" TEE)
③	4" DI PIPE, FLANGE x MECHANICAL JOINT SPOOL, (LENGTH VARIES)
④	4" 90° DI FLANGED x MECHANICAL JOINT ELBOW
⑤	4" DI FLANGED x MECHANICAL JOINT GATE VALVE
⑥	4" DI PIPE (LENGTH VARIES)
⑦	4" 90° DI FLANG x MECHANICAL JOINT ELBOW
⑧	4" MECHANICAL JOINT MEGALUG KIT PER PLANS & SPECIFICATIONS
⑨	4" DI PIPE FLANGE x MECHANICAL JOINT (LENGTH VARIES)
⑩	ARI D-060 COMBINATION AIR VALVE OR APPROVED EQUAL
⑪	POLYETHYLENE ENCLOSURE VCAS-1830 OR APPROVED EQUAL. (CONTRACTOR VERIFY SIZE PRIOR TO INSTALLATION)

NOTE:

1. COMBINATION AIR VALVE SHOWN RESEMBLES A SINGLE MANUFACTURER TYPE. CONTRACTOR SHALL INCLUDE ALL PARTS AND SPECIFIC CONNECTION TYPES FOR MANUFACTURER TYPE INCLUDED WITHIN BID. ADDITIONALLY, IT IS THE CONTRACTORS RESPONSIBILITY TO ENSURE SELECTED STEEL ENCLOSURE FITS THE RESPECTIVE AIR VALVE MANUFACTURER TYPE.
2. FINAL LOCATION TO BE DETERMINED IN FIELD BY OWNER AT NO ADDITIONAL COST.
3. RESTRAINT JOINTS SHALL BE USED IN LIEU OF THRUST BLOCKS WHERE APPLICABLE.
4. ALL DUCTILE IRON PIPE TO BE WRAPPED WITH 8 MIL POLY WRAP PER LAKE HAVASU CITY SPECIFICATIONS.
5. IF SMALLER ARV IS SPECIFIED. APPROPRIATE REDUCER SHALL BE PLACED WITHIN SLAB.

 <p>LAKE HAVASU CITY</p>	<p>Standard Details</p>	<p>4" Combination Air/Vacuum Valve</p>	<p>Scale: <u>N.T.S.</u></p>
	<p>Water Improvements</p>		<p>Detail No.</p> <p>312</p>

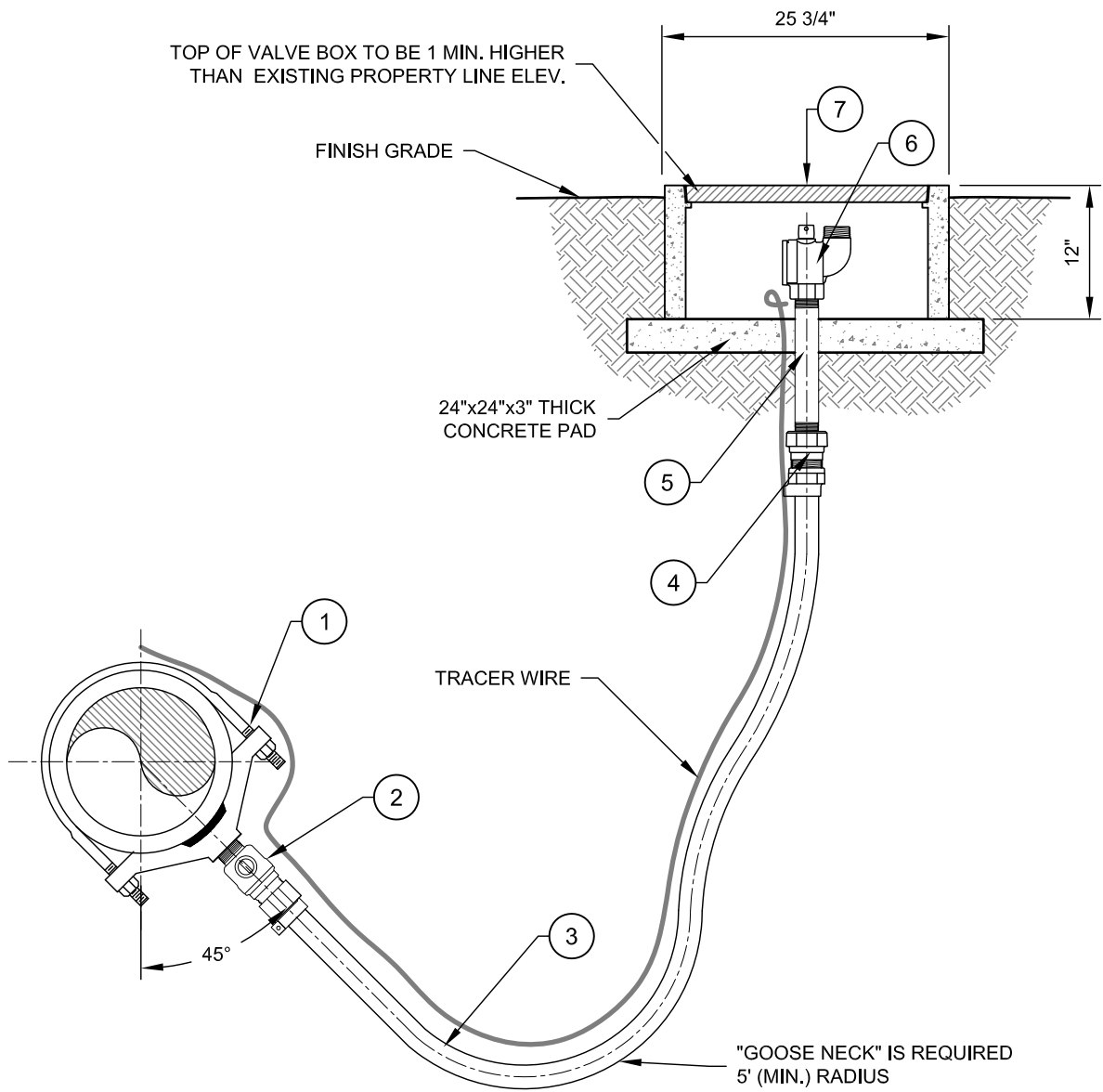

BLOW-OFF ASSEMBLY DETAIL TABLE

ITEM NO.	SIZE AND DESCRIPTION	MATERIAL SPECIFICATIONS	REMARKS
①	2" x MAIN SIZE BRASS SADDLE	FORD 202B-xxx-IP7 (AC) OR S91-xx7 (C900) SADDLE WITH IP THREAD	OR EQUAL
②	2" CORP STOP	FORD 2" FB1100-7-NL	OR EQUAL
③	2" POLY TUBING	POLYETHYLENE PLASTIC TUBING (CTS)(200 PSI) STAINLESS STEEL INSERTS (2" FORD INSERT #55)	
④	2" PACK JOINT COUPLING	FORD 2" C14-77-NL OR EQUAL	
⑤	2"x12" NIPPLE	2"x12" BRASS NIPPLE	
⑥	2" BLOW-OFF VALVE	FORD 2" BLA18-777-TA-NL	OR EQUAL
⑦	METER BOX	MAG SPEC 320 CONCRETE METER BOX (25 3/4"x18"x12")	



Standard Details

Water Improvements

2" Blow-Off Assembly In Line

Scale: N.T.S.

Detail No.

313

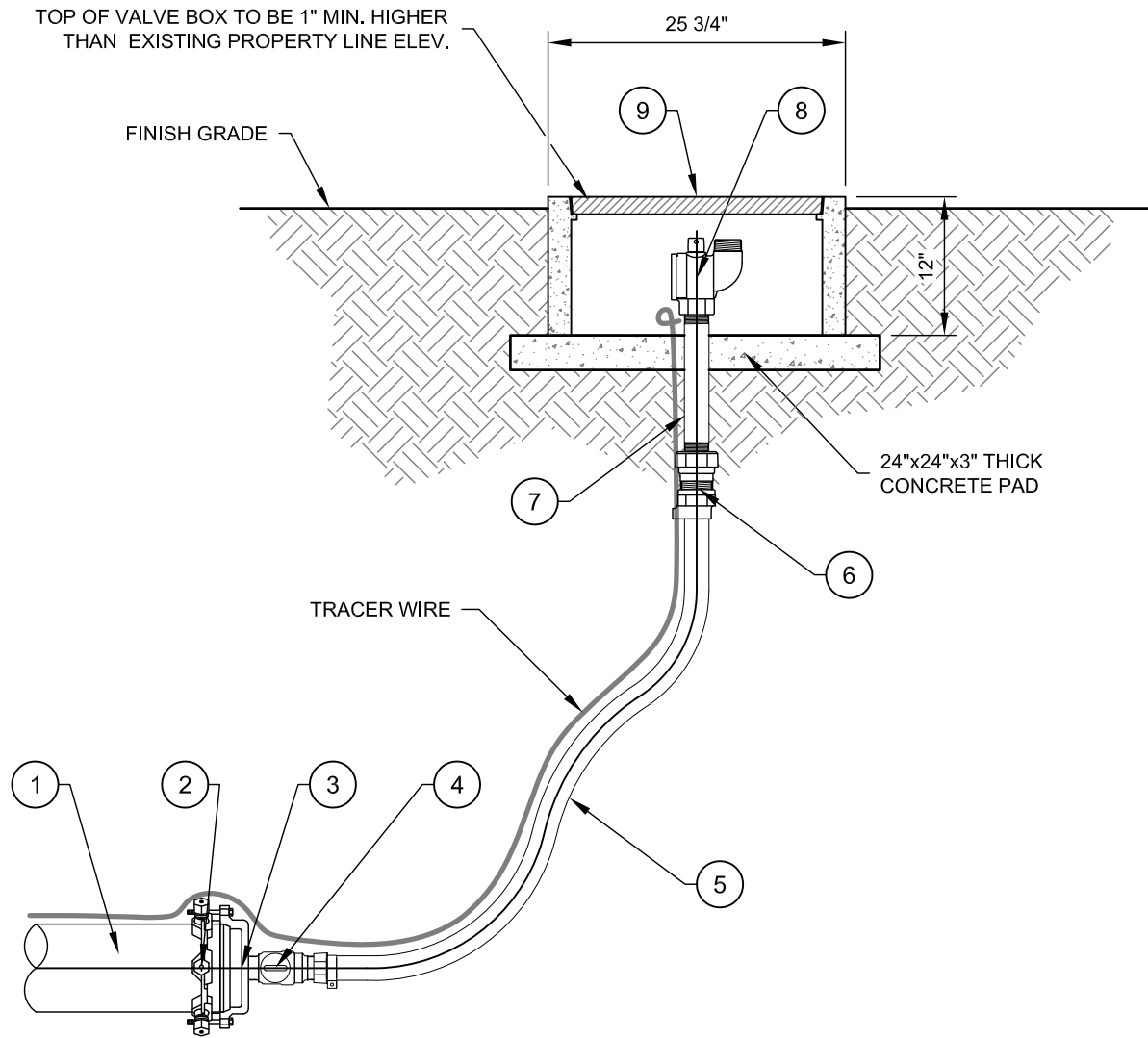

NOTE: S = SIZE IN INCHES

BLOW-OFF ASSEMBLY DETAIL TABLE		
ITEM NO.	SIZE AND DESCRIPTION	MATERIAL SPECIFICATIONS
①	S" PVC PIPE	C900 PVC PIPE (S= SIZE IN INCHES)
②	S" JOINT RESTRAINT	EBAA 2000PV JOIST RESTRAINT OR EQUAL (S= SIZE IN INCHES)
③	S" MECHANICAL JOINT CAP	US PIPE MECHANICAL JOINT CAP WITH CENTER THREADED OPENING (S= SIZE IN INCHES)
④	2" CORP STOP	FORD 2" FB1100-7-NL OR EQUAL
⑤	2" POLY TUBING	POLYETHYLENE PLASTIC TUBING (CTS)(200 PSI) STAINLESS STEEL INSERTS (2" FORD INSERT #55)
⑥	2" PACK JOINT COUPLING	2" PACK JOINT COUPLING
⑦	2"x12" NIPPLE	2"x12" BRASS NIPPLE
⑧	2" BLOW-OFF VALVE	FORD 2" BLA18-777-TA-NL OR EQUAL
⑨	METER BOX	MAG SPEC 320 CONCRETE METER BOX (25 3/4" x 18" x 12")



Standard Details
Water Improvements

2" Blow-Off Assembly End of Line

Scale: N.T.S.
Detail No.
314

TYLER ADJUSTABLE SCREW TYPE RISER
ASSEMBLY OR APPROVED EQUAL
INSTALLATION PER LAKE HAVASU CITY
STANDARD (DETAIL #300)

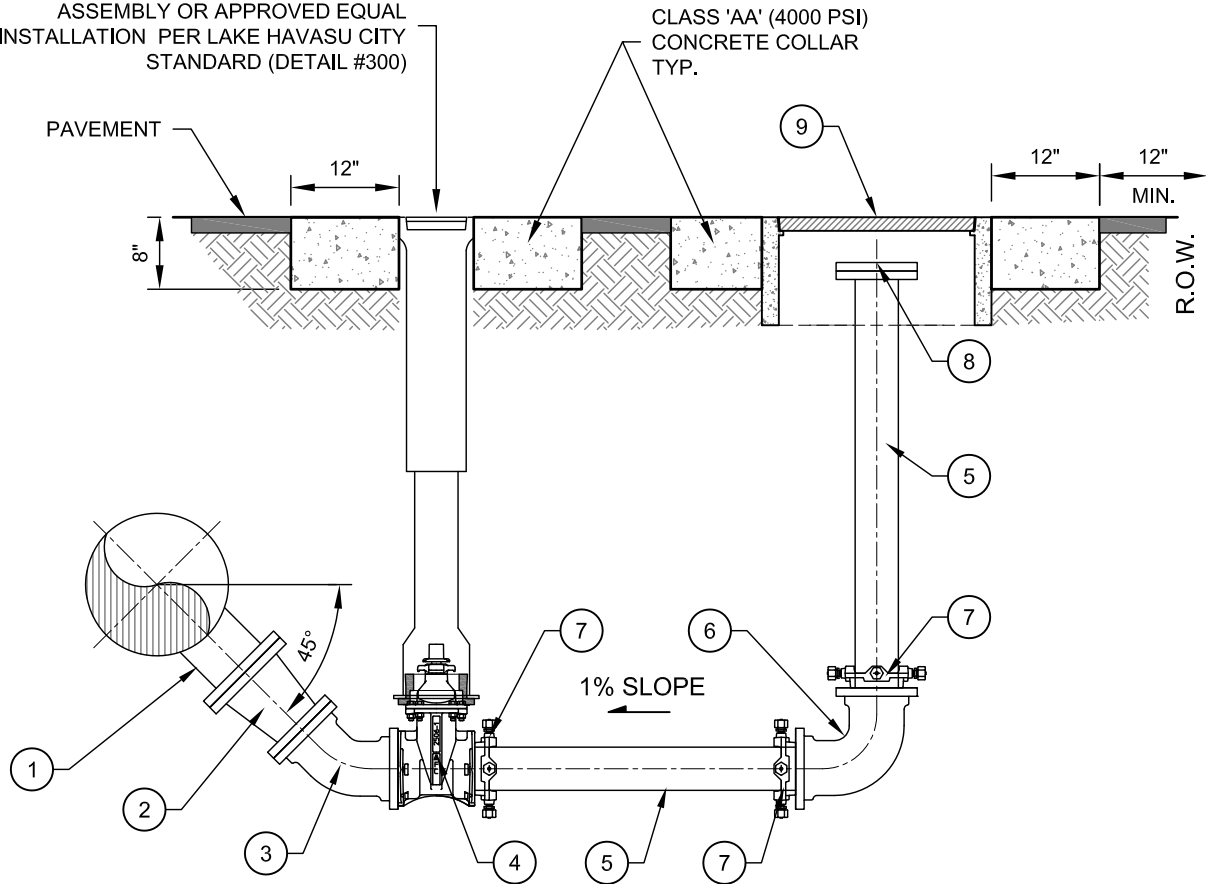

BLOW-OFF ASSEMBLY DETAIL TABLE	
ITEM NO.	SIZE AND DESCRIPTION
①	S"xS"x6" OR 4" DI FLANGED TEE
②	6"x4" DI FLANGED REDUCER (NOT USED WITH S"xS"x4" TEE)
③	4" 45° DI FLANGED ELBOW
④	4" DI FLANGED x MECHANICAL JOINT GATE VALVE
⑤	4" DI PIPE, FLANGE x MECHANICAL JOINT SPOOL, (LENGTH VARIES)
⑥	4" 90° DI MECHANICAL JOINT ELBOW
⑦	4" MECHANICAL JOINT EBAA MEGALUG KIT PER PLANS & SPECIFICATIONS OR APPROVED EQUAL
⑧	4" DI BLIND FLANGE
⑨	CHRISTY MAG #2 (25 1/2"x17 3/4"x12") VALVE BOX OR APPROVED EQUAL.

NOTE:

1. S = SIZE IN INCHES
2. ALL DUCTILE IRON PIPE TO BE WRAPPED WITH 8 MIL POLY WRAP. PER SPECIFICATIONS.

 LAKE HAVASU CITY	Standard Details	4" Blow-Off Assembly	Scale: <u>N.T.S.</u>
	Water Improvements		Detail No. 315

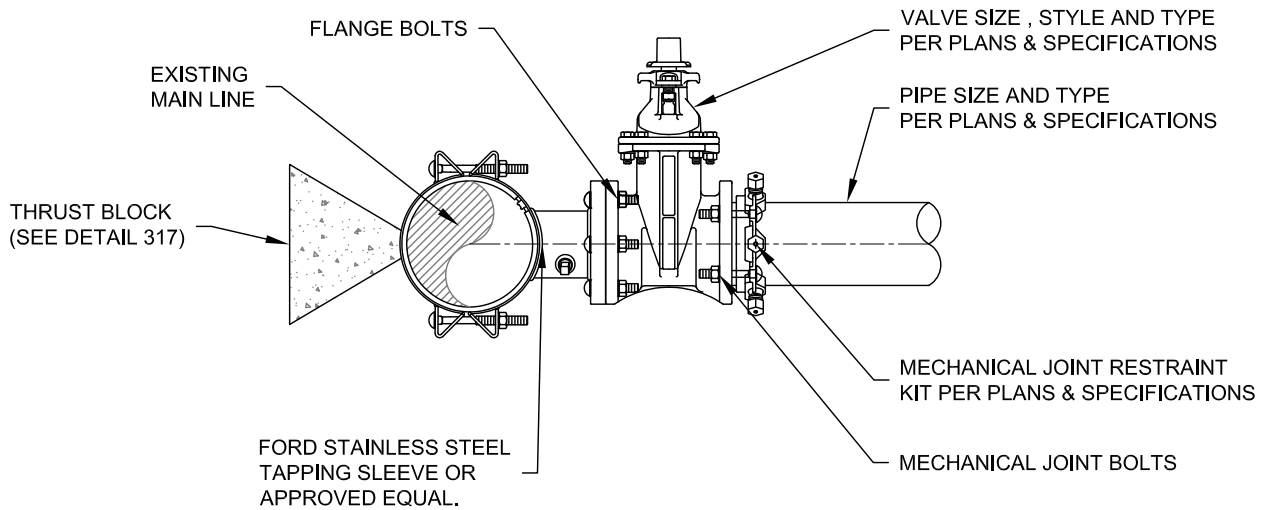

NOTES:

1. **HOT TOP WITH LAKE HAVASU CITY ENGINEERING APPROVAL ONLY.**
2. INSTALL VALVE CAN PER LAKE HAVASU CITY STANDARD DETAIL #300
3. TAPPING SLEEVE AND VALVE SHALL BE INSPECTED AND PRESSURE TESTED BY LAKE HAVASU CITY WATER DIVISION.
4. HOT TAP SHALL BE DONE BY LAKE HAVASU CITY WATER DIVISION WITH AT LEAST 48 HOUR NOTICE.
5. UNIVERSAL COUPLINGS, TAPPING SLEEVE, GATE VALVES, DUCTILE IRON FITTINGS SHALL BE DOUBLE POLY WRAPPED AND TAPED PER LAKE HAVASU CITY STANDARDS SPECIFICATIONS.

 LAKE HAVASU CITY	Standard Details	Hot Tap w/ Gate Valve	Scale: <u>N.T.S.</u>
	Water Improvements		Detail No. 316

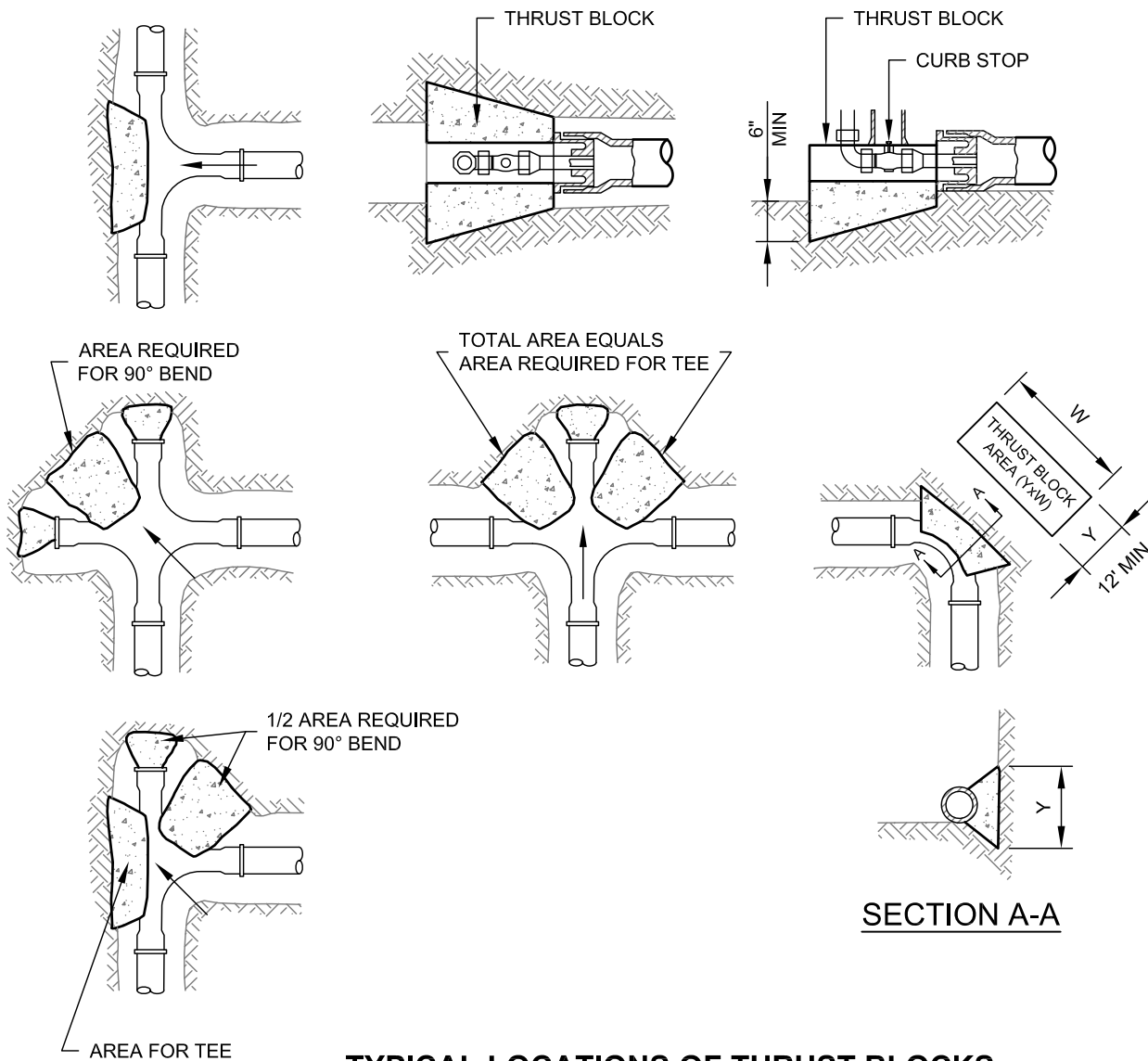

TYPICAL LOCATIONS OF THRUST BLOCKS

NOTES:

1. TABLE IS BASED ON 2,000 P.S.I. TEST PRESSURE AND 3,000 LBS/SQ FT. SOIL. IF CONDITIONS ARE FOUND TO INDICATE SOIL BEARING IS LESS, THE AREAS SHALL BE INCREASED ACCORDINGLY.
2. AREAS FOR PIPES LARGER THAN 16" SHALL BE CALCULATED FOR EACH PROJECT.
3. FORM ALL NON-BEARING VERTICAL SURFACES.
4. THRUST BLOCKS ARE TO EXTEND TO UNDISTURBED GROUND. CONCRETE TO BE CLASS 'AA' 4000 PSI. FORM AS REQUIRED TO KEEP CLEAR OF JOINTS
5. ALL DI PIPE AND FITTINGS TO BE DOUBLE POLY WRAPPED BEFORE THRUST BLOCK INSTALLATION.

MINIMUM TRUST BLOCK AREA REQUIRED (YxW) (SQ. FT.)		
PIPE SIZE	WATER PIPE	
	TEE, DEAD END, 90° BEND	45° & 22 1/2" BENDS
4" OR LESS	3	3
6"	4	3
8"	6	3
10"	10	5
12"	14	7
16"	24	12

	Standard Details	Thrust Blocks For Water Lines	Scale: <u>N.T.S.</u>
	Water Improvements		Detail No. 317

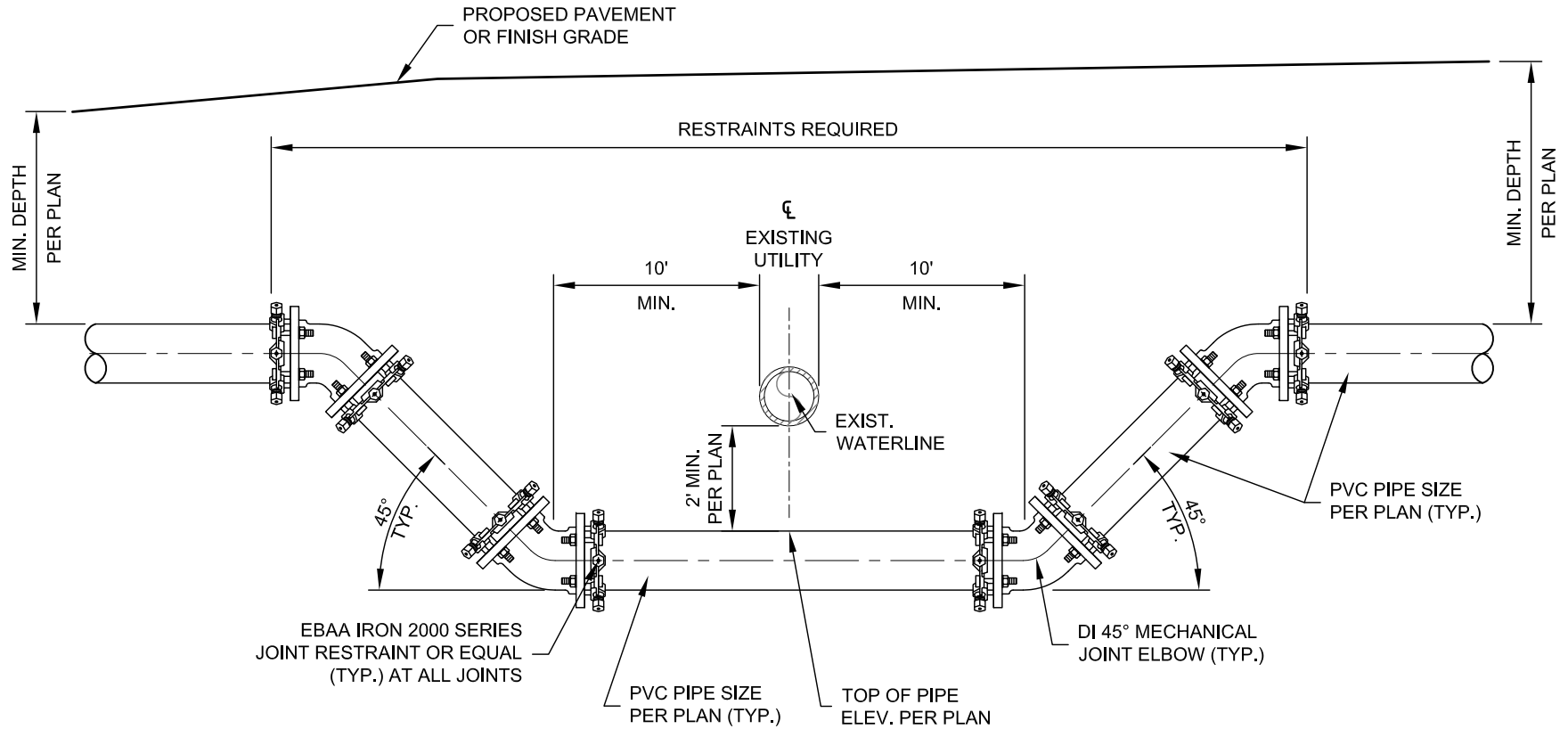

NOTES:

1. CONTRACTOR SHALL FIELD VERIFY WATERLINE LOCATION.
2. ALL PIPE FITTINGS SHALL BE PVC, SIZE TO MATCH PLANS.
3. ALL PVC PIPE SHALL BE CONSTRUCTED WITH FLANGE RESTRAINTS.
4. ELBOWS ONLY REQUIRED IF SHOWN ON PLANS.
5. S = SIZE IN INCHES.

	Standard Details	Typical Drop Under Existing Waterline	Scale: <u>N.T.S.</u>
	Water Improvements		Detail No. 318

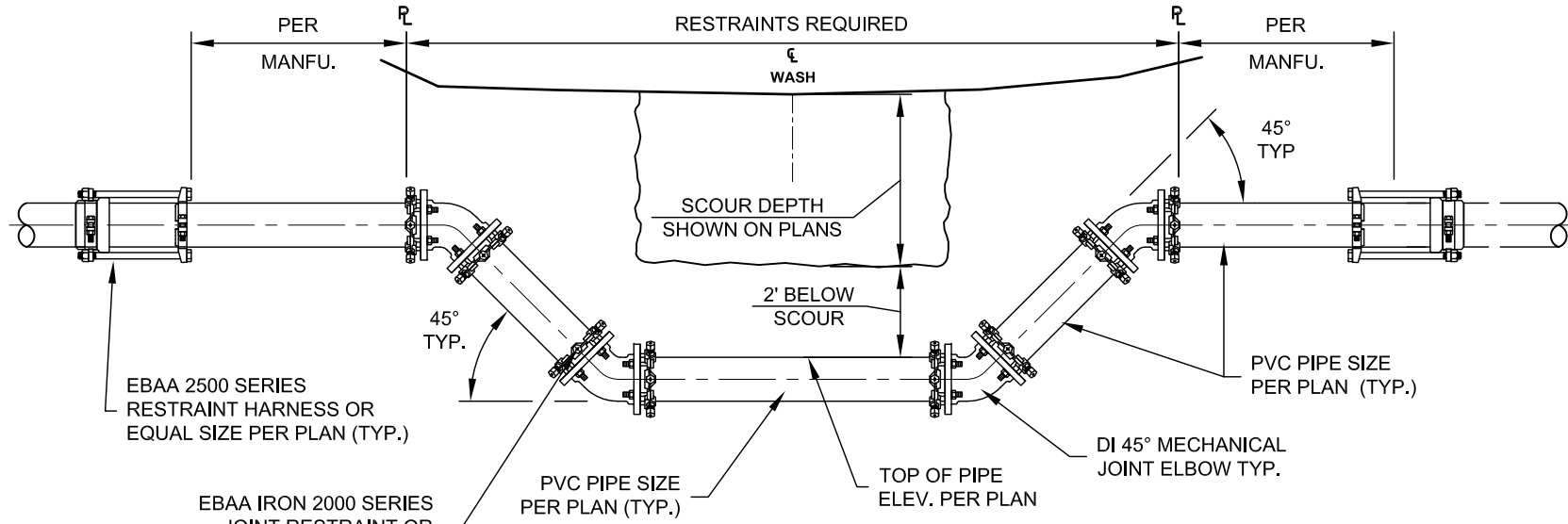

CUT-OFF WALL NOT INCLUDED

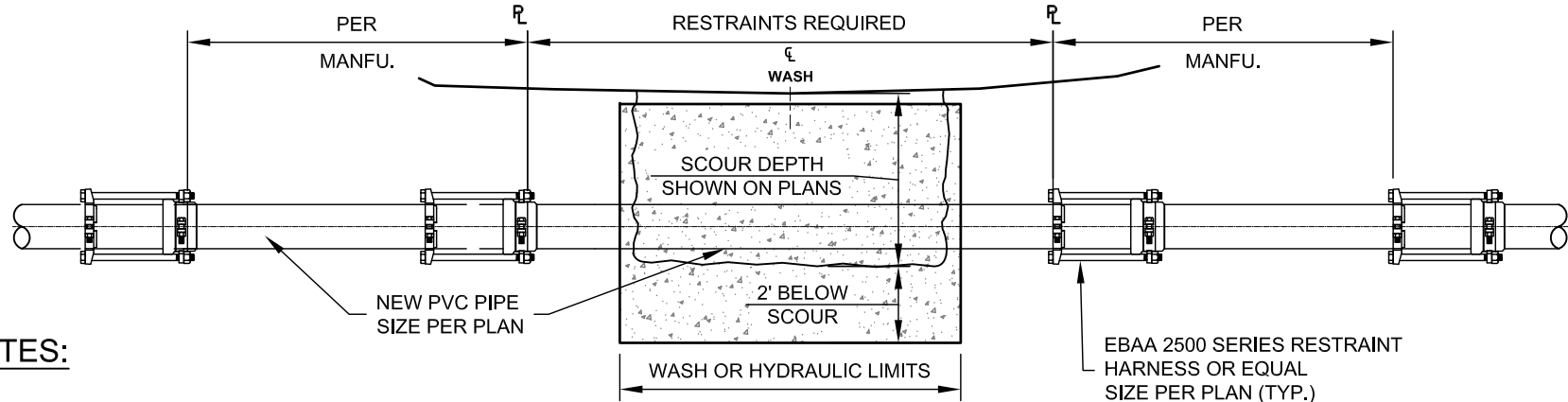

NOTES:

1. CONTRACTOR SHALL FIELD VERIFY SCOUR LOCATION.
2. ALL PIPE FITTINGS SHALL BE DUCTILE IRON, SIZE TO MATCH PLANS.
3. ALL DUCTILE IRON FITTINGS TO BE WRAPPED WITH 8 MIL POLY WRAP, PER SPECIFICATIONS.
4. ELBOWS ONLY REQUIRED IF SHOWN IN PLANS.

CUT-OFF WALL INCLUDED

	Standard Details	Typical Wash Crossing	Scale: <u>N.T.S.</u>
	Water Improvements		Detail No. 319

STREET TYPE	'D'
BOULEVARD	34'-0"
AVENUE	29'-0"
DRIVE	28'-0"
CUL-DE-SAC	23'-0"

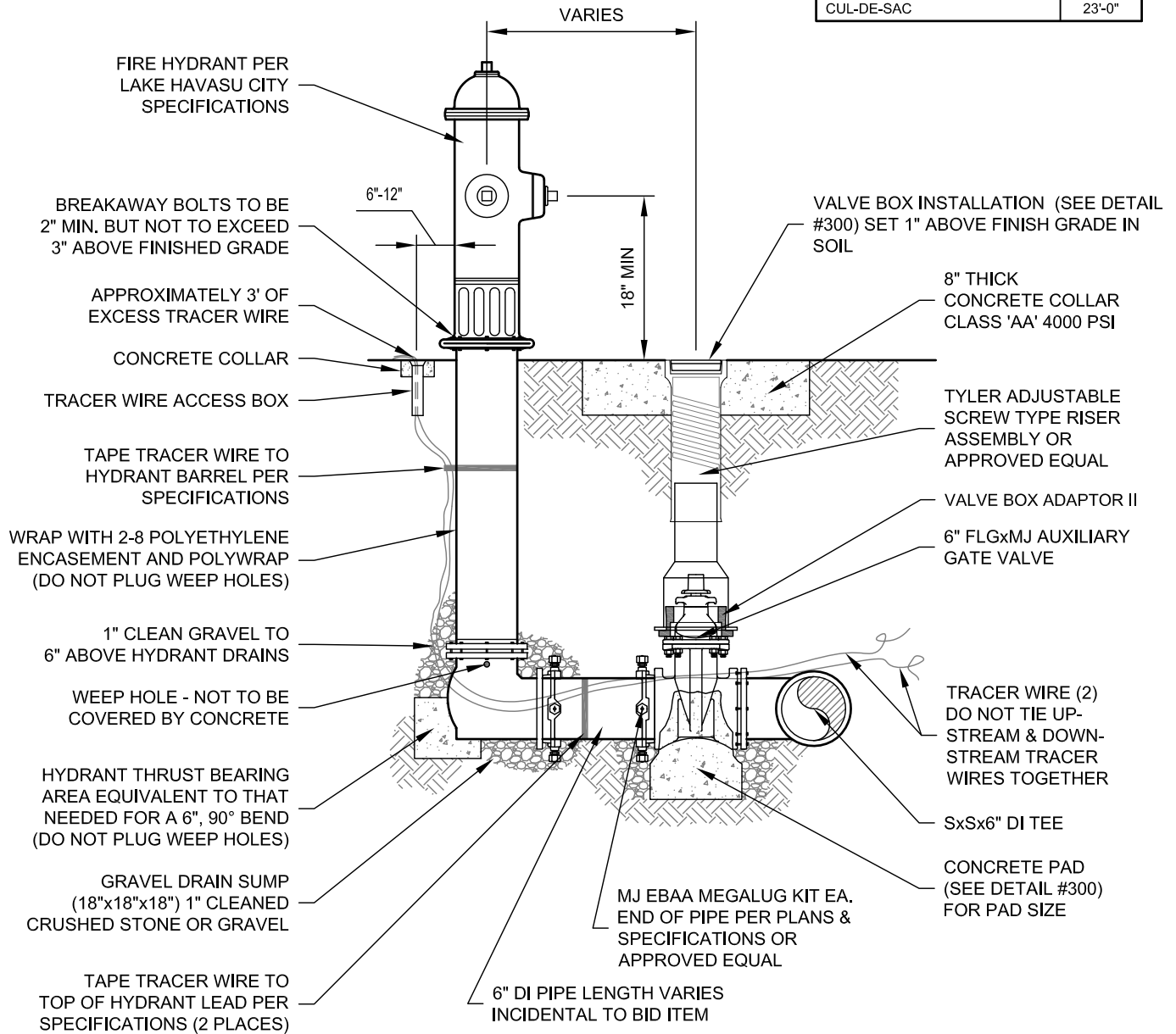

NOTE:

1. THE CONTRACTOR SHALL VERIFY FIELD CONDITIONS PRIOR TO SUBMITTAL. APPROVAL SHALL BE OBTAINED PRIOR TO ORDERING OF PARTS. CONTRACTOR IS RESPONSIBLE FOR APPROPRIATE BARREL LENGTH TO ACCOMMODATE ANY CHANGE IN GRADE OR PIPE ELEVATION.
2. PUMPER CONNECTIONS TO FACE BUILDINGS OR STREET.
3. S = MAIN SIZE.

 <p>LAKE HAVASU CITY</p>	Standard Details	6" Fire Hydrant	Scale: <u>N.T.S.</u>
	Water Improvements		Detail No.
			320

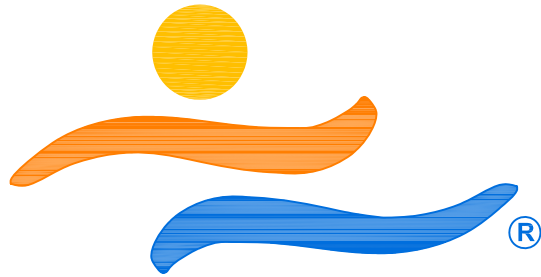

LAKE HAVASU CITY

**WASTEWATER
IMPROVEMENTS**

SCHEDULE 40 SMOOTH
STEEL PIPE CASING
WITH STANDARD WALL
THICKNESS (SEE TABLE)

GLASS REINFORCE
PLASTIC SKIDS OR
APPROVED EQUAL

STEEL CASING
INSULATOR

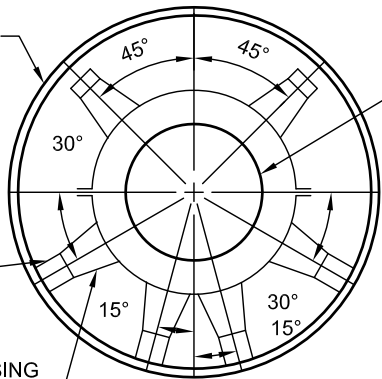

**CARRIER PIPE SIZES
15" THROUGH 24"**

SCHEDULE 40 SMOOTH
STEEL PIPE CASING
WITH STANDARD WALL
THICKNESS (SEE TABLE)

SDR 35 PVC
RESTRAINED JOINT
(ROMAC STYLE 517
OR EQUAL)

GLASS REINFORCE
PLASTIC SKIDS OR
APPROVED EQUAL

STEEL CASING
INSULATOR

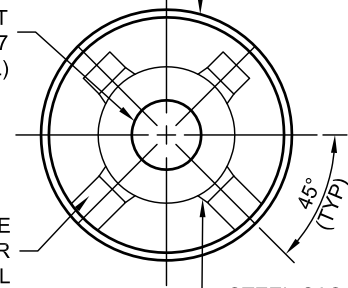

**CARRIER PIPE
SIZES 4" THROUGH 12"**

RESTAIN ALL JOINTS
WITH "ROMAC STYLE 517" BRAND OR APPROVED EQUAL

RUBBER CASING
END SEAL OR
APPROVED EQUAL

SDR 35 PVC
RESTRAINED JOINT
(ROMAC STYLE 517
BELL JOINT LEAK
CLAMPS OR EQUAL)

FLEX COUPLING OR
JOINT PIPE

STAINLESS STEEL
BANDS (TYPICAL)

INSTALL STEEL CASING
INSULATOR WITH GLASS
REINFORCED PLASTIC
SKIDS
(NO REDWOOD ALLOWED)

SCHEDULE 40 SMOOTH
STEEL PIPE CASING.
SHALL BE 2-LAYER
POLYWRAPPED

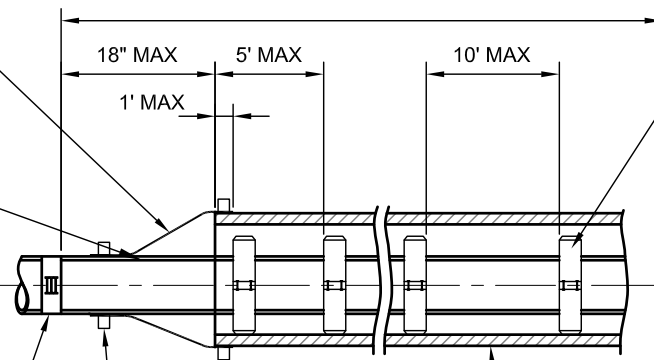

INSTALL STEEL CASING,
INSULATOR WITH GLASS
REINFORCED PLASTIC
SKIDS
OR APPROVED EQUAL

SDR 35 PVC
RESTRAINED JOINT
(ROMAC STYLE 517
OR EQUAL)

BUTT WELD PER
ASME, SECTION 9

SCHEDULE 40 SMOOTH
STEEL PIPE CASING WITH
STANDARD WALL THICKNESS
OR AS OTHERWISE SPECIFIED

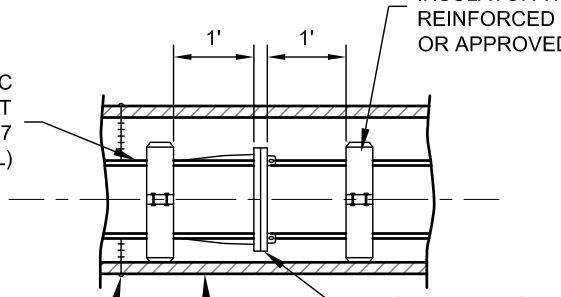

MATERIAL

CARRIER PIPE SIZE (IN)	SCHEDULE 40 SMOOTH STEEL PIPE CASING	
	PIPE WALL THICKNESS (IN)	MIN. CASING SIZE (IN)
6	3/16	16
8	1/4	20
10	1/4	54
12	9/32	54
15	9/32	28



LAKE HAVASU CITY

Standard Details

**Wastewater
Improvements**

**Casing Pipe
and End Seal**

Scale: **N.T.S.**

Detail No.

400

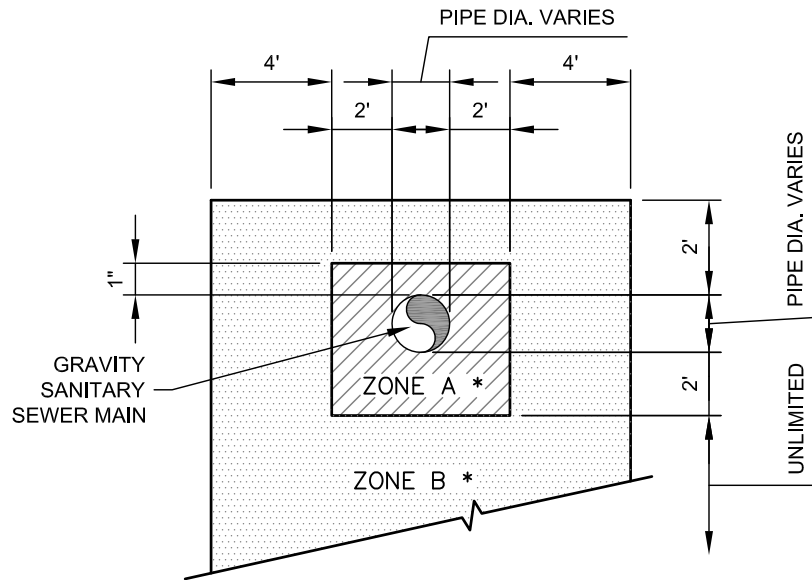

GRAVITY SANITARY SEWER MAIN

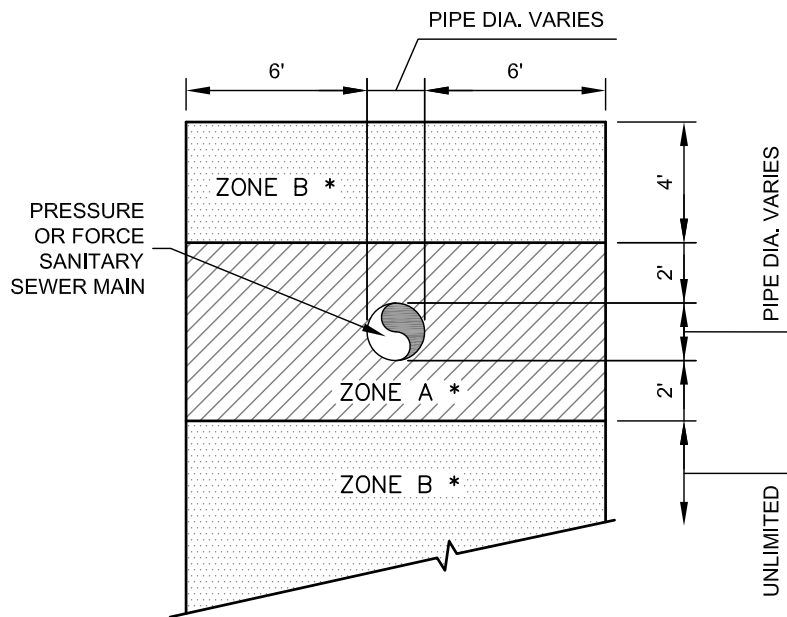

PRESSURE OR FORCE SANITARY SEWER MAIN

	<p>Standard Details</p>	<p>Water/Sewer Zone Separation</p>	<p>Scale: <u>N.T.S.</u></p>
	<p>Wastewater Improvements</p>		<p>Detail No. 401A</p>

NOTES:

1. CONTRACTOR SHALL MAINTAIN SEPARATION DISTANCES OR PROVIDE OTHER EXTRA PROTECTION TO PROTECT WATER MAINS FROM CONTAMINATION BY SANITARY SEWER MAINS.
2. CRITERIA FOR SEPARATION AND/OR EXTRA PROTECTION APPLIES TO PARALLEL MAINS AS WELL AS CROSSINGS WITHIN ZONE B. (SEE DETAIL 401A)
3. SEE CROSS SECTION STANDARD DETAIL 401A FOR LIMITS OF SEPARATION/EXTRA PROTECTION. ALL DISTANCES ARE MEASURED PERPENDICULARLY FROM THE OUTSIDE OF THE PIPES.
 - A. NO WATER MAINS SHALL FALL WITHIN ZONE A. (SEE DETAIL 401A)
 - B. EXTRA PROTECTION WILL BE REQUIRED WHEN THE WATER MAIN FALLS WITHIN ZONE B EXTRA PROTECTION SHALL CONSIST OF CONSTRUCTING THE SANITARY SEWER MAIN WITH MECHANICAL JOINT OR RESTRAINED JOINT DUCTILE IRON PIPE FOR A DISTANCE OF TEN FEET EITHER SIDE OF THE WATER MAIN. THE DUCTILE IRON PIPE SHALL COMPLY WITH THE AGENCY'S REQUIREMENTS FOR SEWER INSTALLATION. IN THE CASE OF A CROSSING, THE NUMBER OF JOINTS SHALL BE HELD TO A MINIMUM, WITH ONE FULL JOINT OF PIPE CENTERED OVER/UNDER THE OTHER. AN ALTERNATE PROTECTION MAY CONSIST OF ENCASING BOTH PIPES IN CONCRETE AS SHOWN IN STANDARD DETAIL 401A.
 - C. NO ADDITIONAL PROTECTION WILL BE REQUIRED OUTSIDE ZONES A AND B. (SEE DETAIL 401A)
4. SEPARATION REQUIREMENTS FOR 4" OR 6" INDIVIDUAL SERVICE CONNECTIONS SHALL COMPLY WITH THE UNIFORM PLUMBING CODE.
5. RECLAIMED WATER SHALL BE CONSIDERED AS POTABLE WATER WHEN PLACED NEXT TO A SANITARY SEWER AND CONSIDERED A SANITARY SEWER WHEN PLACED NEXT TO A POTABLE WATER MAIN UNLESS APPROVED IN WRITING BY THE CITY ENGINEER.

	Standard Details	Water/Sewer Zone Separation Notes	Scale: <u>N.T.S.</u>
	Wastewater Improvements		Detail No. 401B

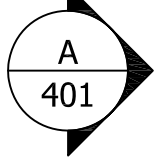
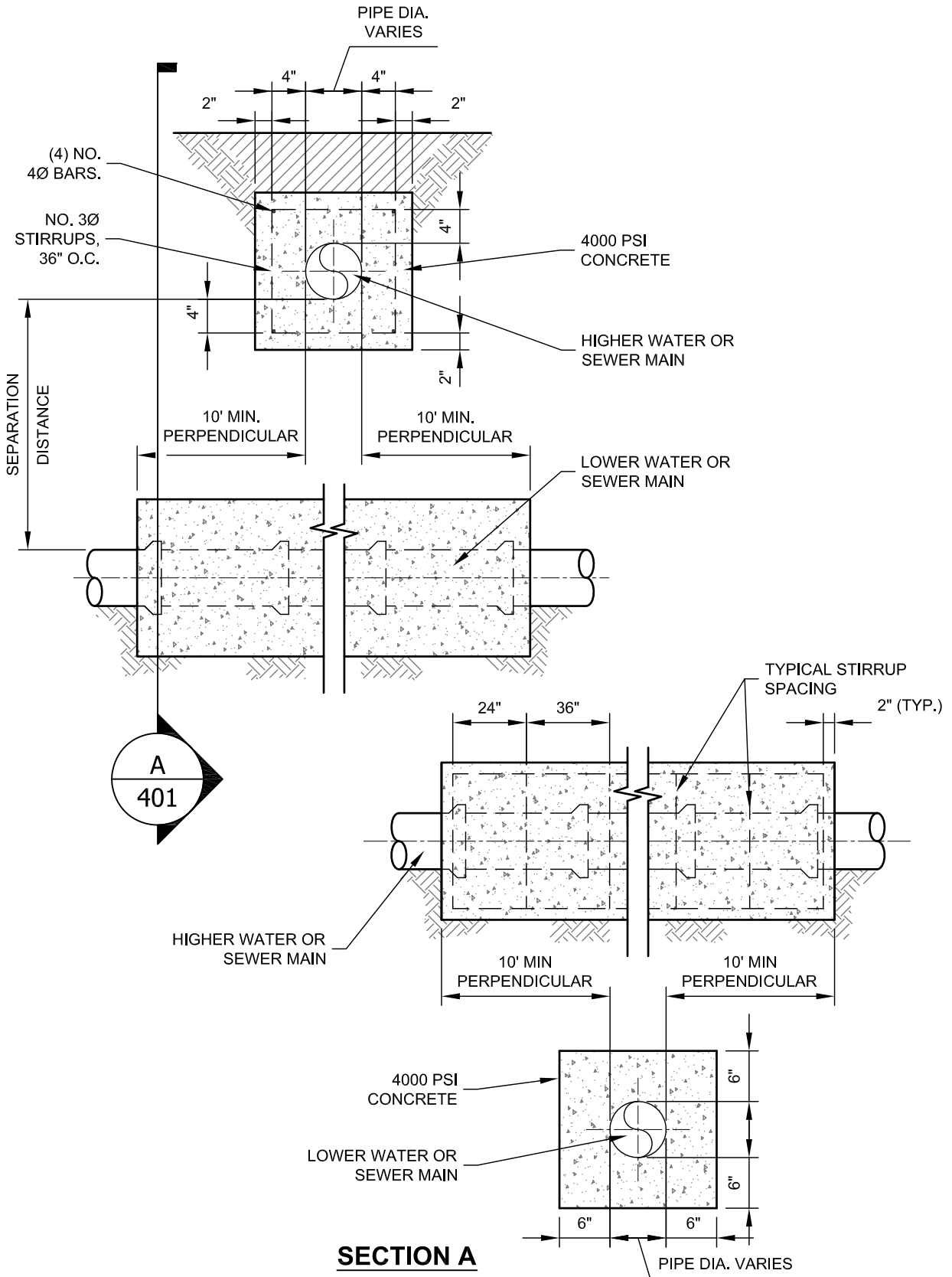

Standard Details

Wastewater Improvements

Water/Sewer Separation & Encasement for Pipe Crossing

Scale: N.T.S.

Detail No.

401C

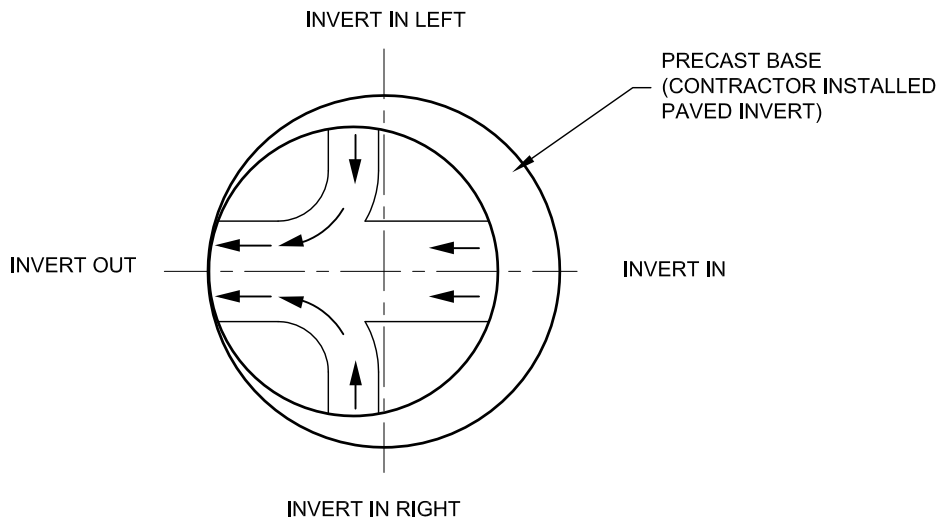

FLOW PLAN

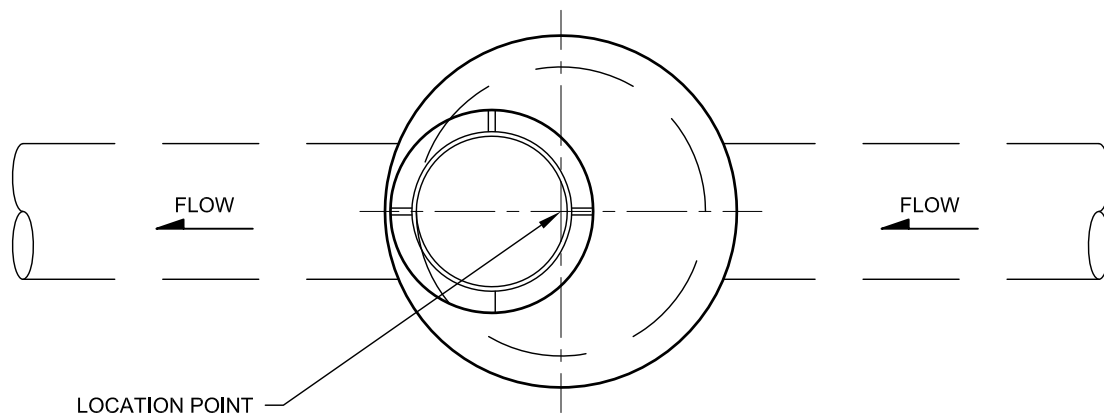

PLAN VIEW

MANHOLE GENERAL NOTES:

1. WATERSTOPS, RAM-NEK SEALS, OR AN APPROVED EQUAL SHALL BE USED ON ALL PIPE PENETRATIONS.
2. INTERIOR SURFACE OF THE MANHOLE SHALL BE SMOOTH, UNIFORM AND SELF-CLEANING. PRECAST CONCRETE MANHOLES SHALL HAVE AN INTERIOR COATING SYSTEM OF PPC AS MANUFACTURED BY POLYMORPHIC POLYMERS CORPORATION; LIFE LAST COATING SYSTEM, OR CITY APPROVED EQUAL AS LISTED.
 DROP MANHOLES,
 INTERCEPTORS.
 FIRST MANHOLES DOWNSTREAM OF A DROP MANHOLE.
 ANY MANHOLE WITH MORE THAN ONE INLET AND MORE THAN ONE OUTLET.
 ANY MANHOLE WHERE SEVERE CHANGES IN DIRECTION OCCUR, AS DEEMED NECESSARY BY CITY.
 FIRST MANHOLE DOWNSTREAM OF FORCE MAIN.
3. MINIMUM OF 0.2 FT DROP BETWEEN INVERTS SLOPE OR PIPE SLOPE SHALL MATCH WHICHEVER IS STEEPER.

	Standard Details	Manhole Invert	Scale: <u>N.T.S.</u>
	Wastewater Improvements		Detail No. 402

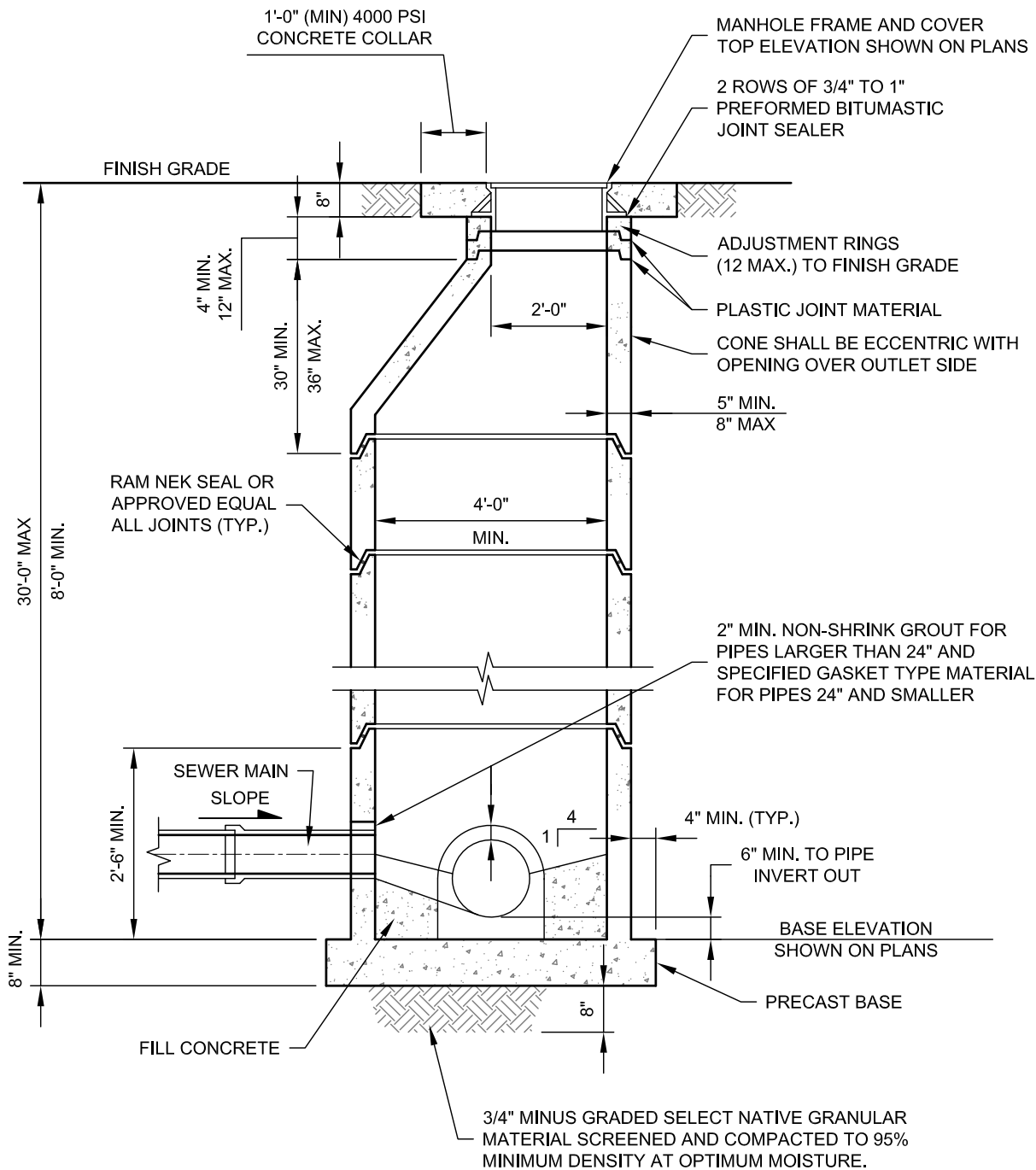

Standard Details

Wastewater Improvements

Precast Concrete Manhole

Scale: N.T.S.

Detail No.

403

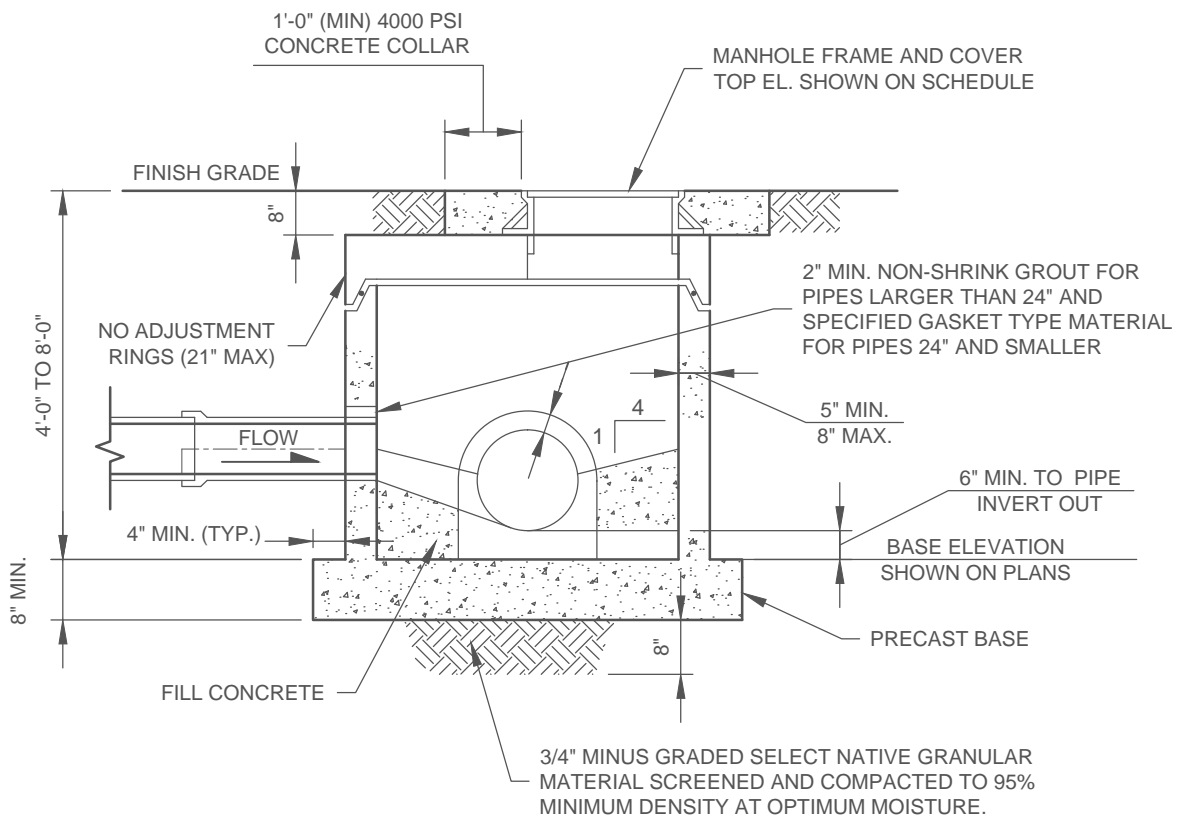

Standard Details
Wastewater Improvements

Shallow Precast Concrete Manhole

Scale: N.T.S.
Detail No.
405



Standard Details
Wastewater Improvements

Manhole Casting Cover

Scale: <u>N.T.S.</u>
Detail No.
406

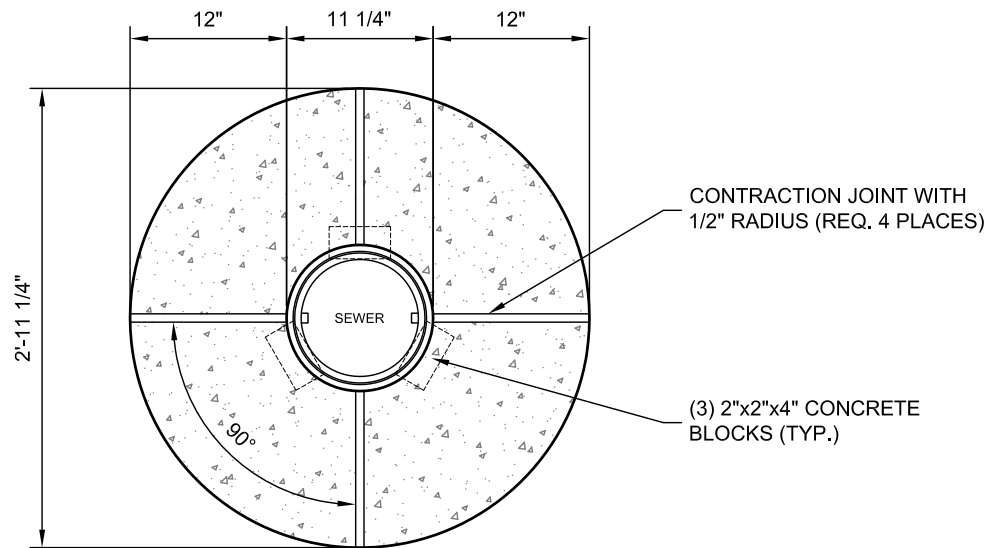

PLAN VIEW

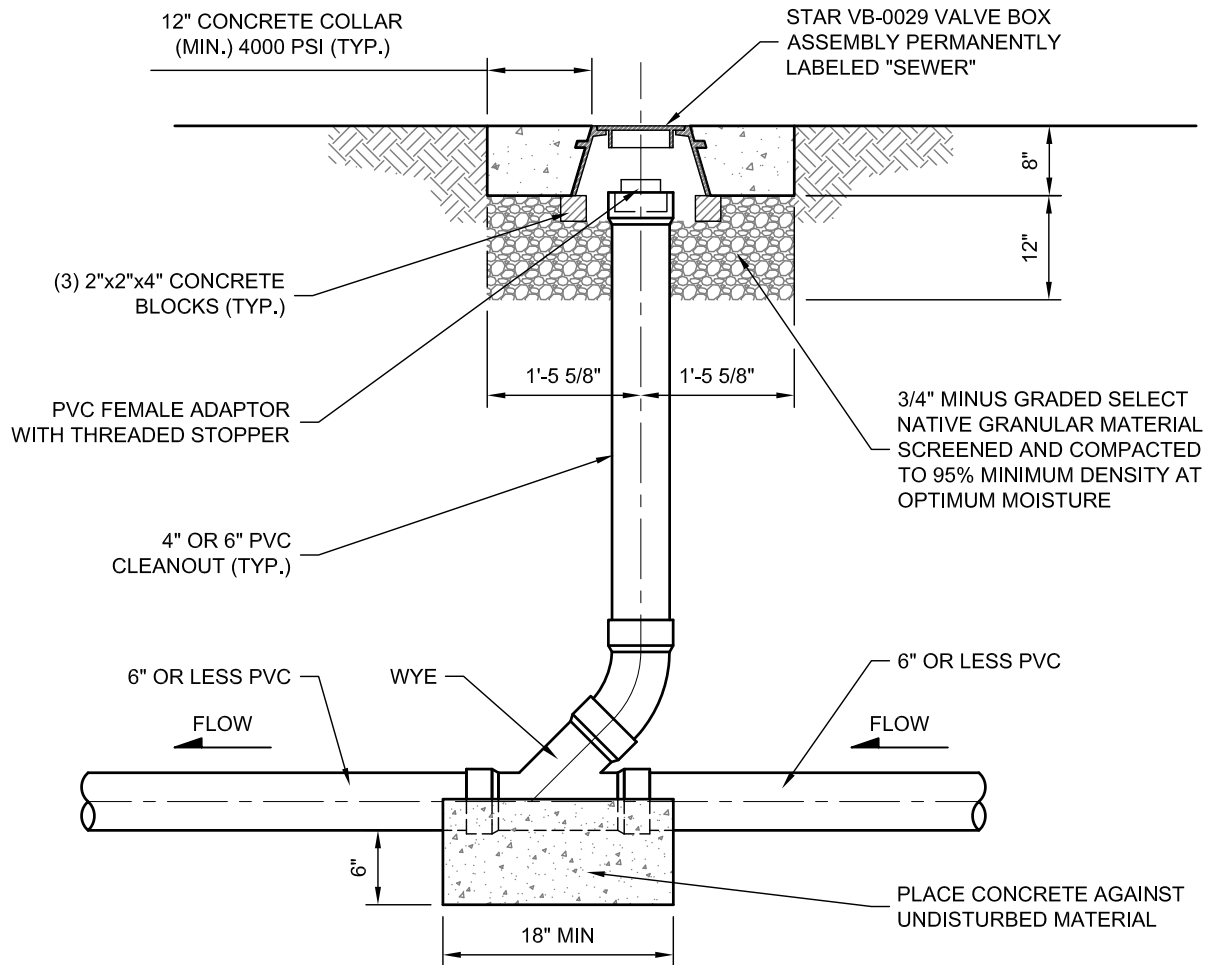

SECTION

	Standard Details	Inline Cleanout	Scale: <u>N.T.S.</u>
	Wastewater Improvements		Detail No. 407

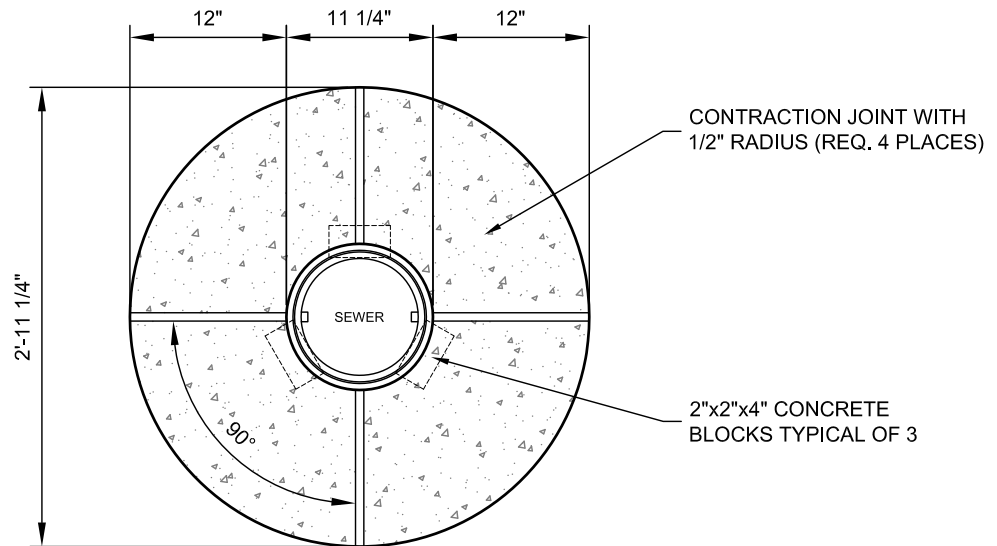

PLAN VIEW

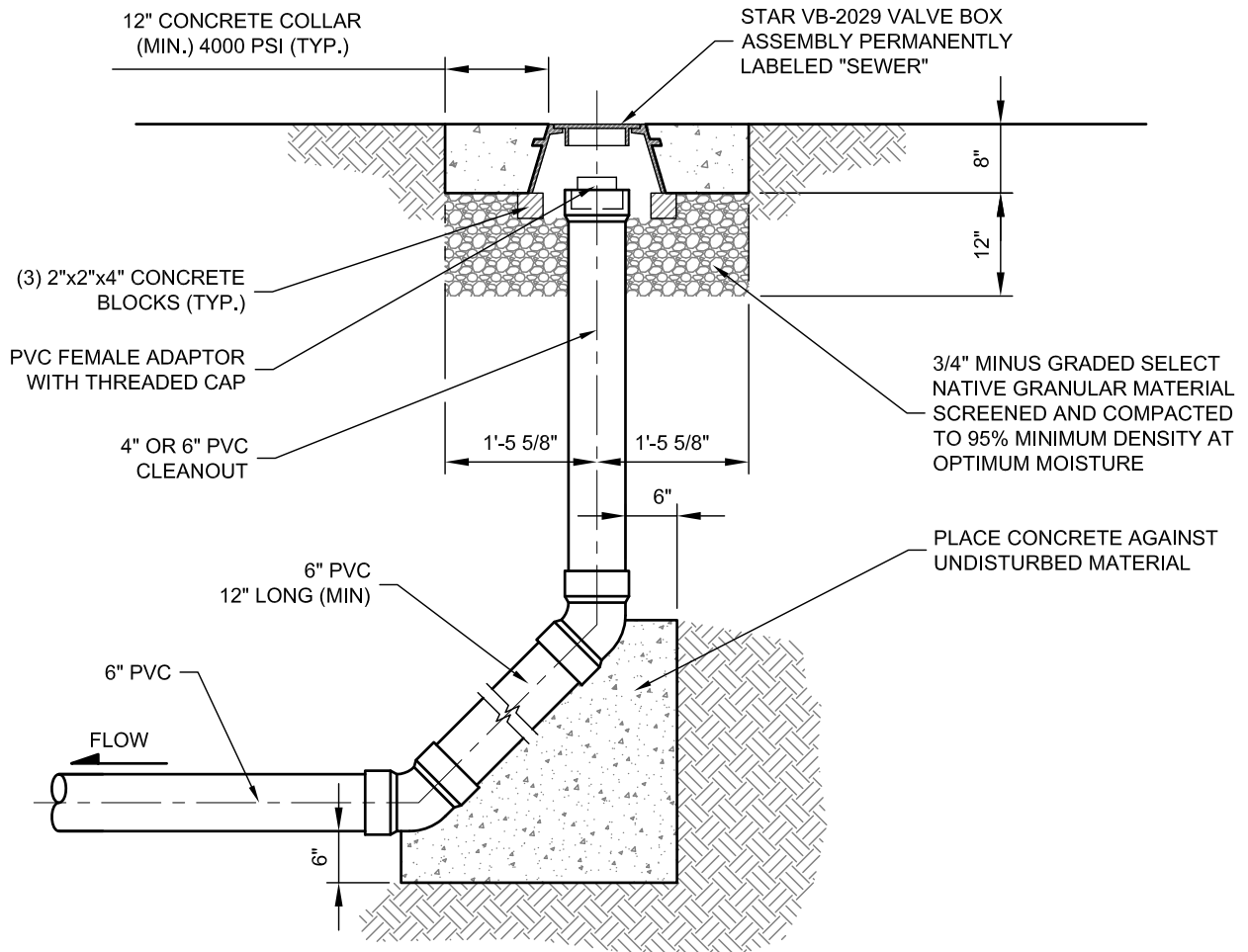

SECTION

	Standard Details	Typical End of Main Cleanout	Scale: <u>N.T.S.</u>
	Wastewater Improvements		Detail No. 408

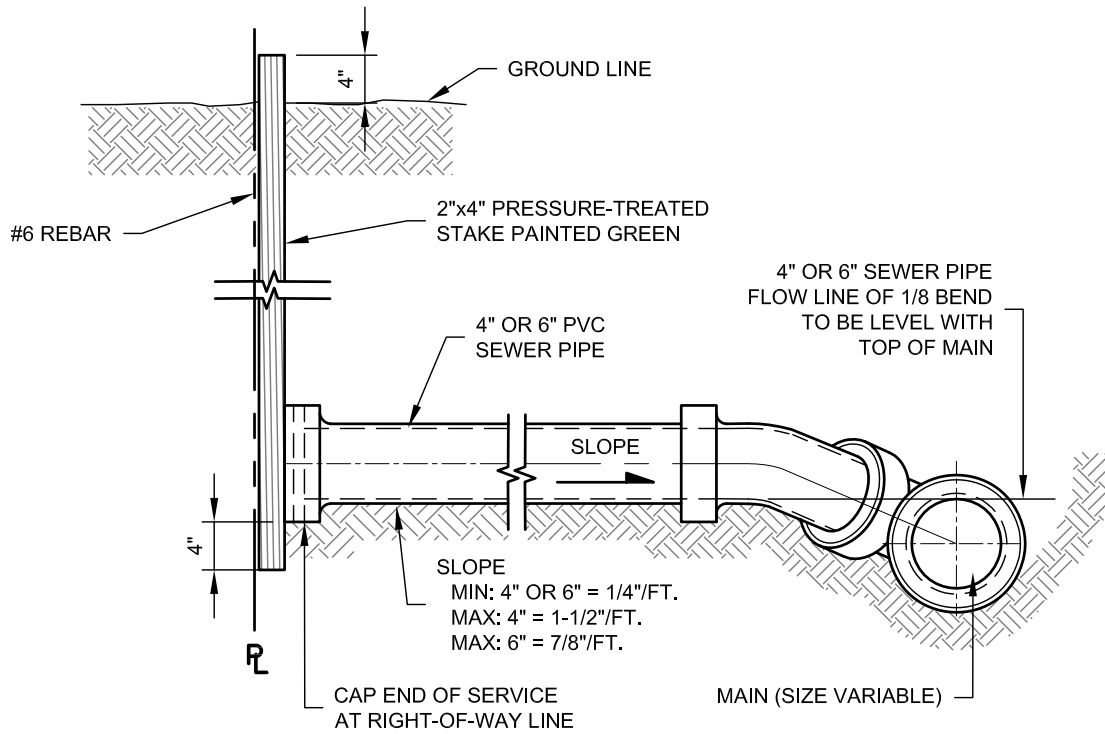

SECTION VIEW

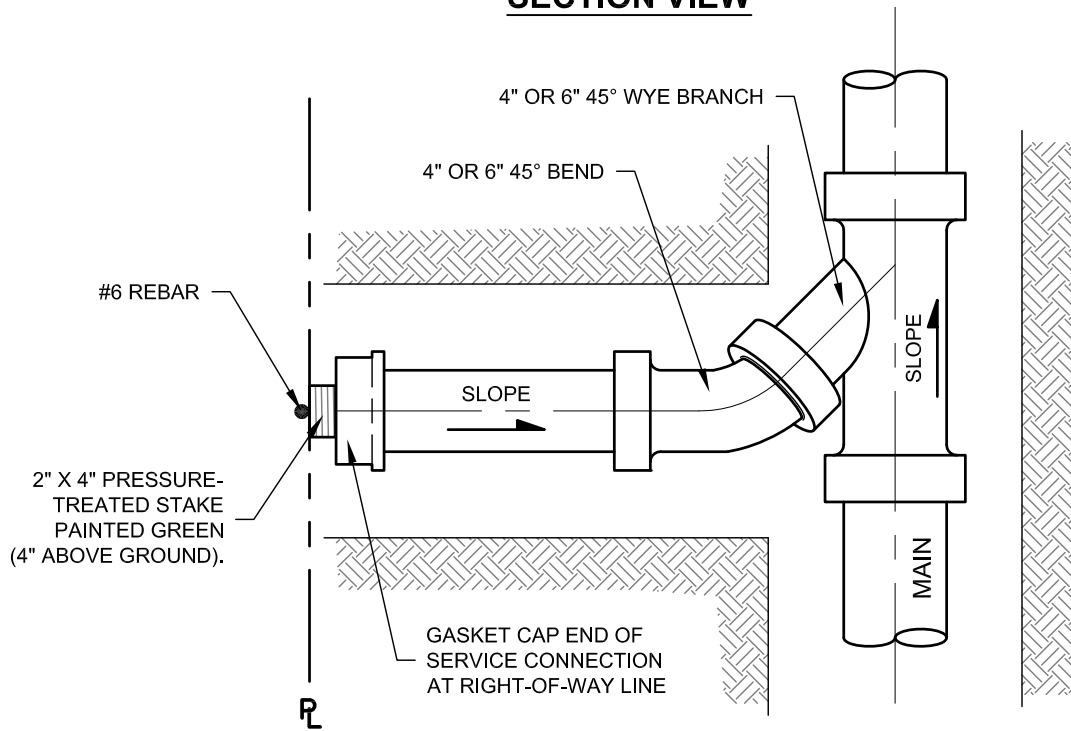

PLAN VIEW

NOTE: USE FOR CONNECTION TO NEW SEWERS

	<p>Standard Details</p>	<p>Sewer Service Connection Vacant Lot</p>	<p>Scale: <u>N.T.S.</u></p>
	<p>Wastewater Improvements</p>		<p>Detail No.</p> <p>409</p>

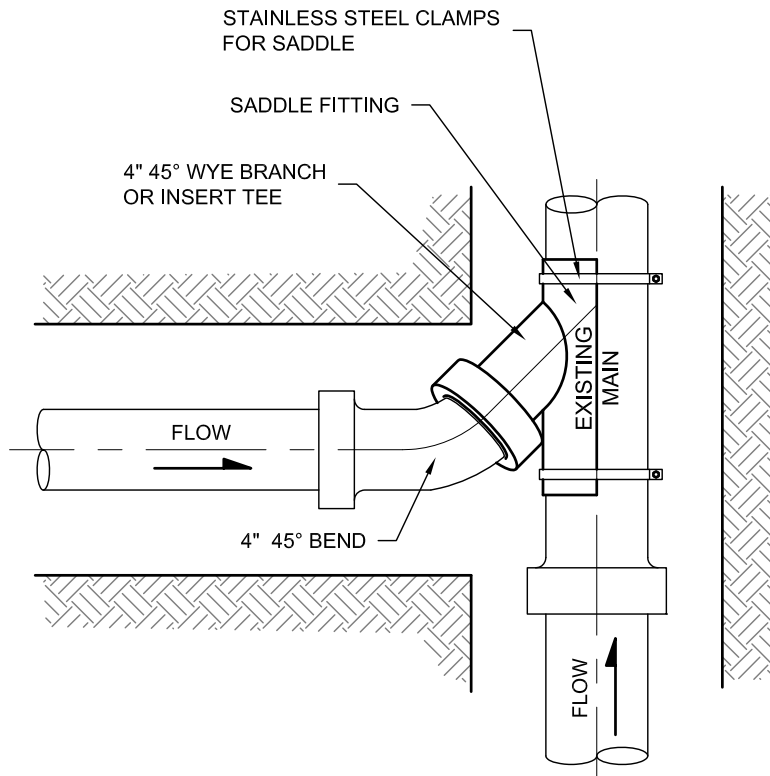

NOTE:

USE ONLY FOR SERVICES CONNECTING TO EXISTING SEWERS.

SERVICE LINE CONNECTION NOTES:

1. CONSTRUCTION DETAIL APPLIES WHERE CONTRACTOR BUILDS HOUSE CONNECTION. TAP EXTENDS TO PROPERTY LINE IN ALLEYS OR STREETS OR TO EASEMENT LINE.
2. SIZE OF SERVICE LINE SHALL BE 4" UNLESS INDICATED OTHERWISE ON PLANS.
3. CONSTRUCT SERVICE LINE AT MINIMUM SLOPE OF 1/4" PER FOOT.
4. FOR DEEPER LATERAL OR TRUNK SEWER CONDITION, THE WYE AND 1/8 BEND OR THE TEE AND 1/16 BEND SHALL BE ROTATED TOWARD THE VERTICAL POSITION AS REQUIRED TO OBTAIN 5'-0" COVER AT PROPERTY LINE OR EASEMENT LINE.
5. END OF SERVICE LINE TO BE CAPPED WITH GASKET CAP AND MARKED WITH 2" X 4" PRESSURE-TREATED STAKE PAINTED GREEN.
6. ROTATE WYE AND 45° ELBOW TO ALIGN FOR CONNECTION

	Standard Details	Sewer Service Connection to Existing Sewer	Scale: <u>N.T.S.</u>
	Wastewater Improvements		Detail No. 410

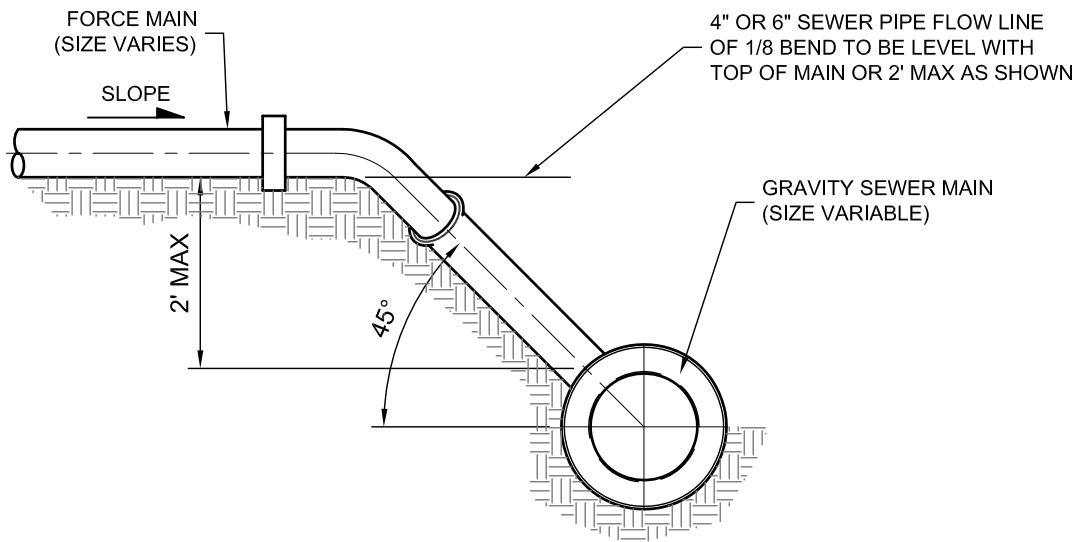

SECTION A

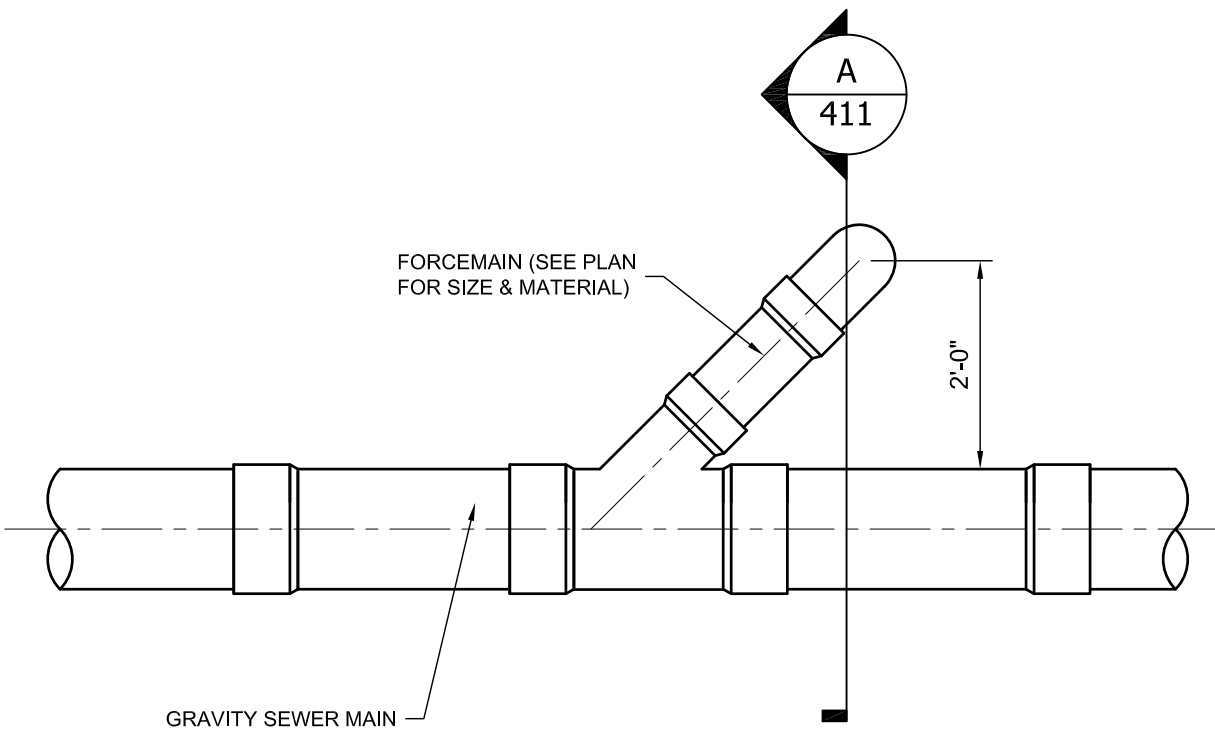

	Standard Details	Force Main Connection	Scale: <u>N.T.S.</u>
	Wastewater Improvements		Detail No. 411

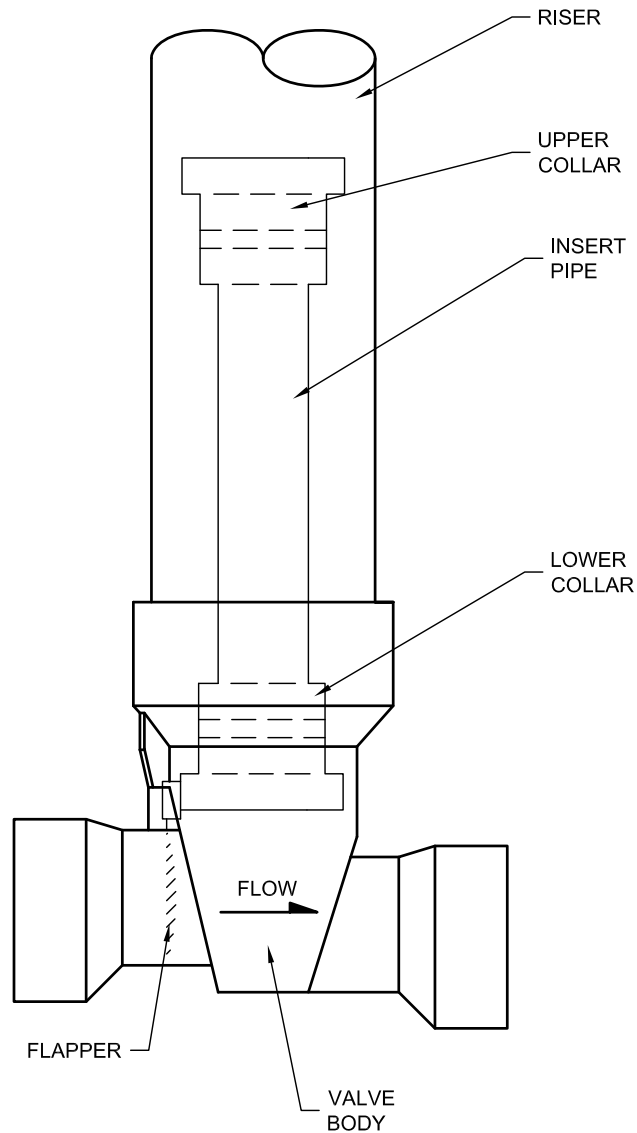

CONSTRUCTION NOTES:

1. CONTRACTOR SHALL INSTALL NEW PVC BACKWATER VALVE PER DETAIL AT A MAXIMUM SLOPE OF 1/4" PER FOOT. THE BACKWATER VALVE LOCATION MAY BE ADJUSTED TO ENSURE MAXIMUM SLOPE IS NOT EXCEEDED.
2. CONTRACTOR SHALL INSTALL 4" PVC CLEAN CHECK EXTENDABLE BACKWATER VALVE OR EQUAL.

	Standard Details	Backwater Valve	Scale: <u>N.T.S.</u>
	Wastewater Improvements		Detail No. 412

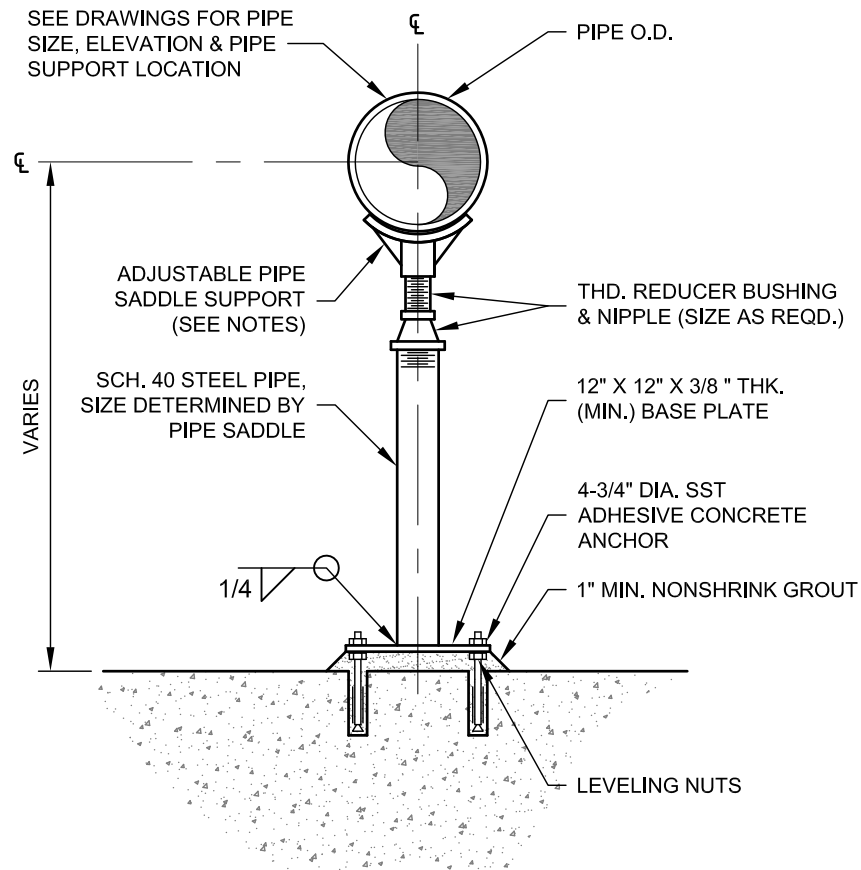

NOTES:

1. WHERE PIPE SUPPORT IS INDICATED, LOCATED UNDER VALVE, PROVIDE ADJUSTABLE PLATE SUPPORT IN LIEU OF SADDLE SUPPORT.
2. COAT PIPE SYSTEM AS SPECIFIED.

	Standard Details	Pipe Support Saddle	Scale: <u>N.T.S.</u>
	Wastewater Improvements		Detail No. 413

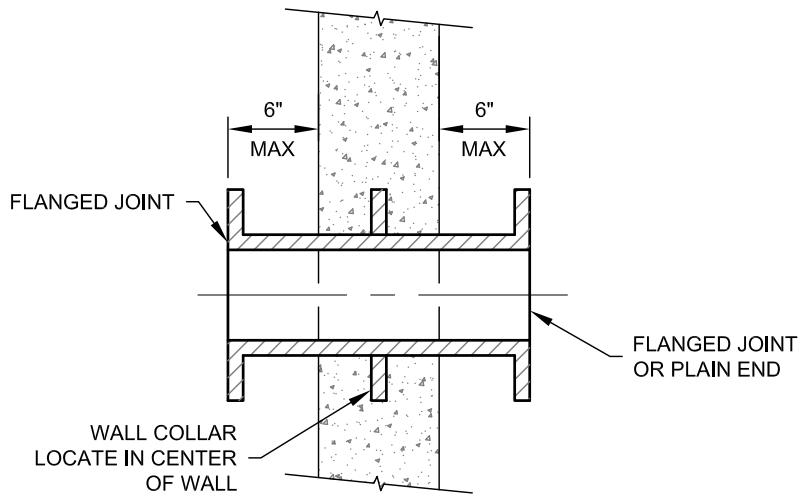

INTERIOR WALL

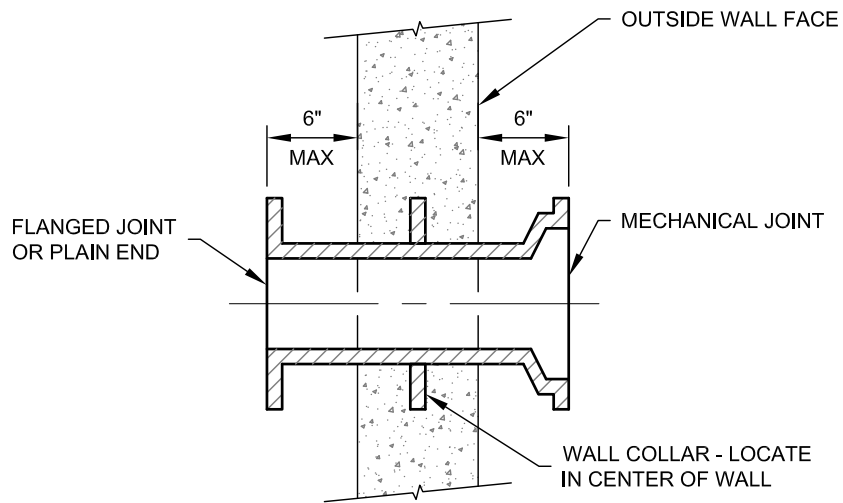

EXTERIOR WALL

NOTES:

1. UNLESS OTHERWISE NOTED, WALL PIPE MATERIALS SHALL BE THE SAME SIZE AS PIPING SYSTEM DESIGN.

	Standard Details	Typical Wall Pipe	Scale: <u>N.T.S.</u>
	Wastewater Improvements		Detail No. 414

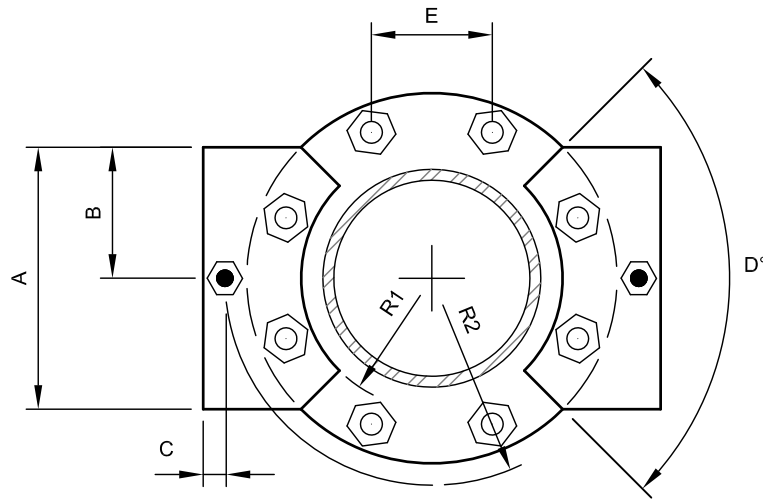



PIPE DIA.	PLATE THICKNESS	A	B	C	D°	E	R1	R2	NO. OF TIE RODS REQUIRED	(A-36) DIA. OF THE RODS	TEST PRESSURE PSI
4"	.375"	6.5"	3.25"	.75"	92.50	2.87"	2.875"	5.1875"	2	.375"	200
6"	.375"	8.0"	4.00"	.75"	93.33	3.64"	3.875"	6.1875"	2	.50"	200
8"	.375"	9.5"	4.75"	.75"	89.50	4.49"	4.875"	7.4375"	2	.75"	200

NOTE:

DIMENSIONS INDICATED IN TABLE ARE IN INCHES EXCEPT FOR COLUMN D, WHICH INDICATES DEGREES.

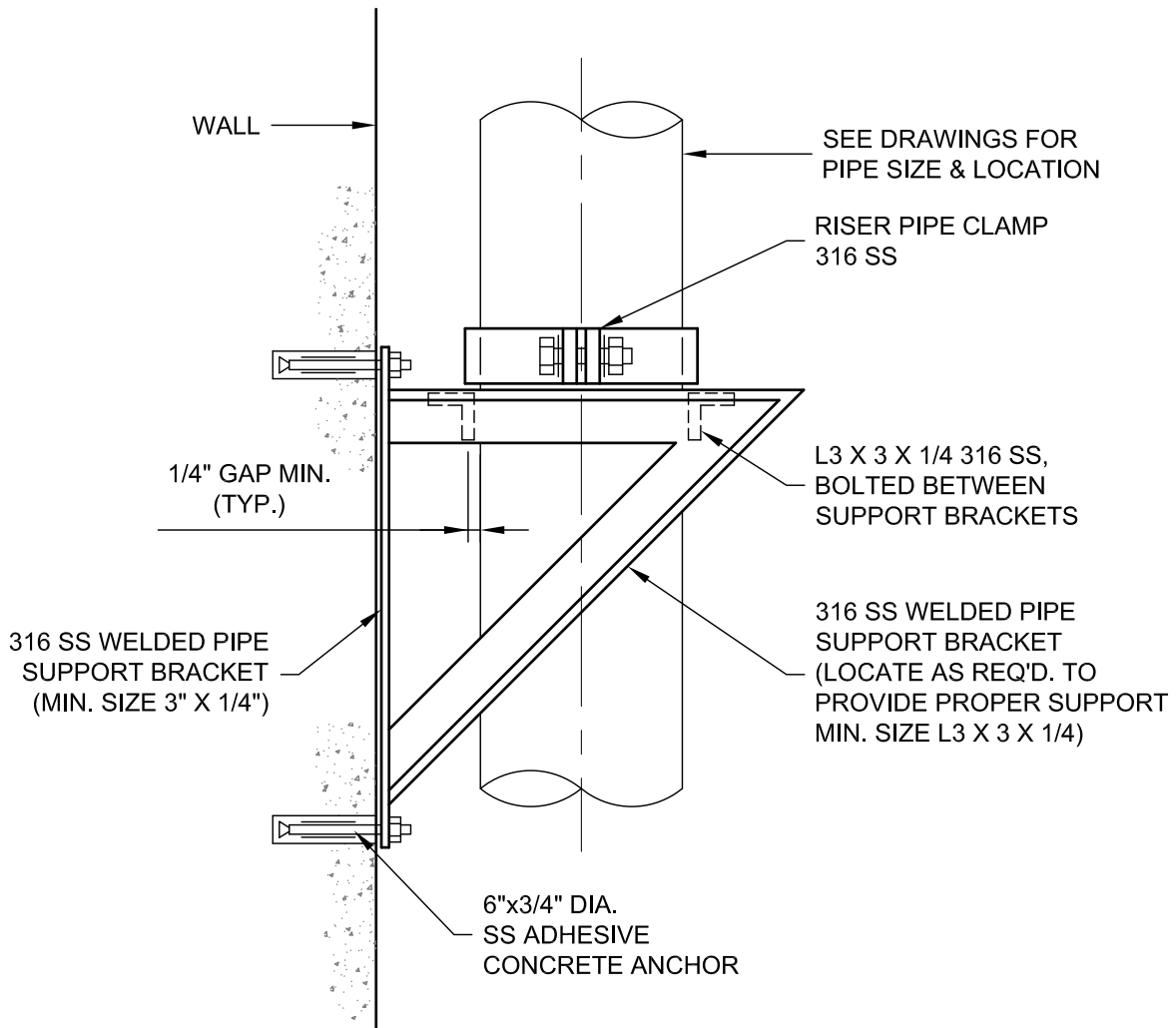
	Standard Details	Harnessed Sleeve Coupling Tied-Rod	Scale: <u>N.T.S.</u>
	Wastewater Improvements		Detail No. 415



	Standard Details	Wall Pipe Support	Scale: <u>N.T.S.</u>
	Wastewater Improvements		Detail No. 416

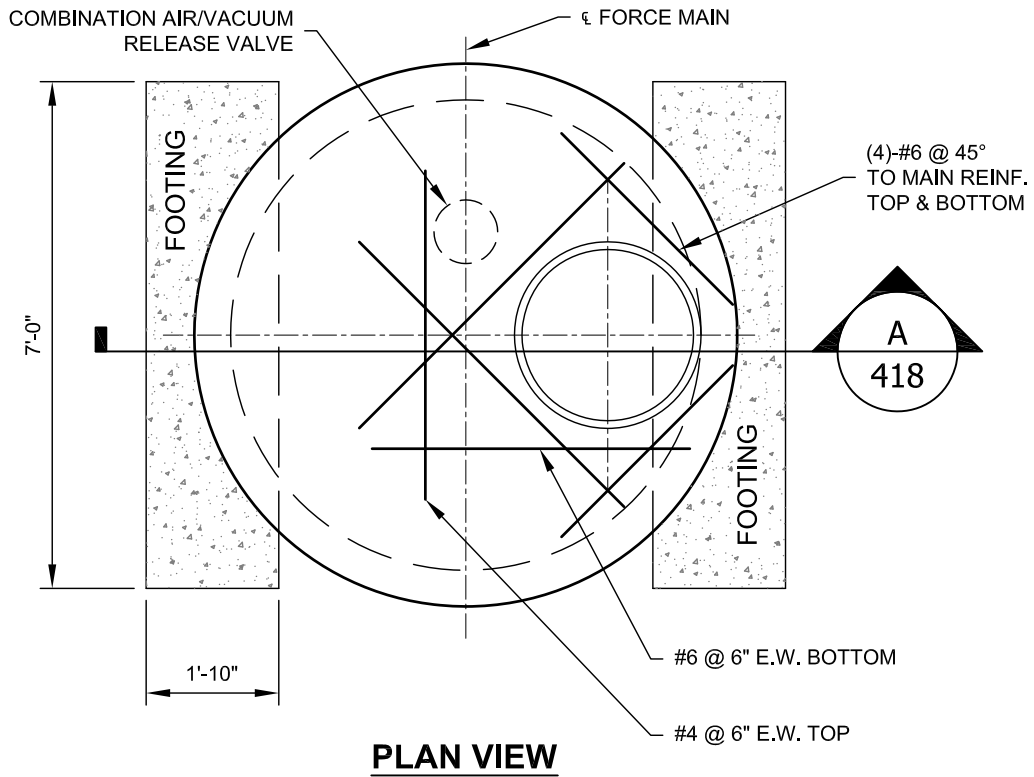

PLAN VIEW

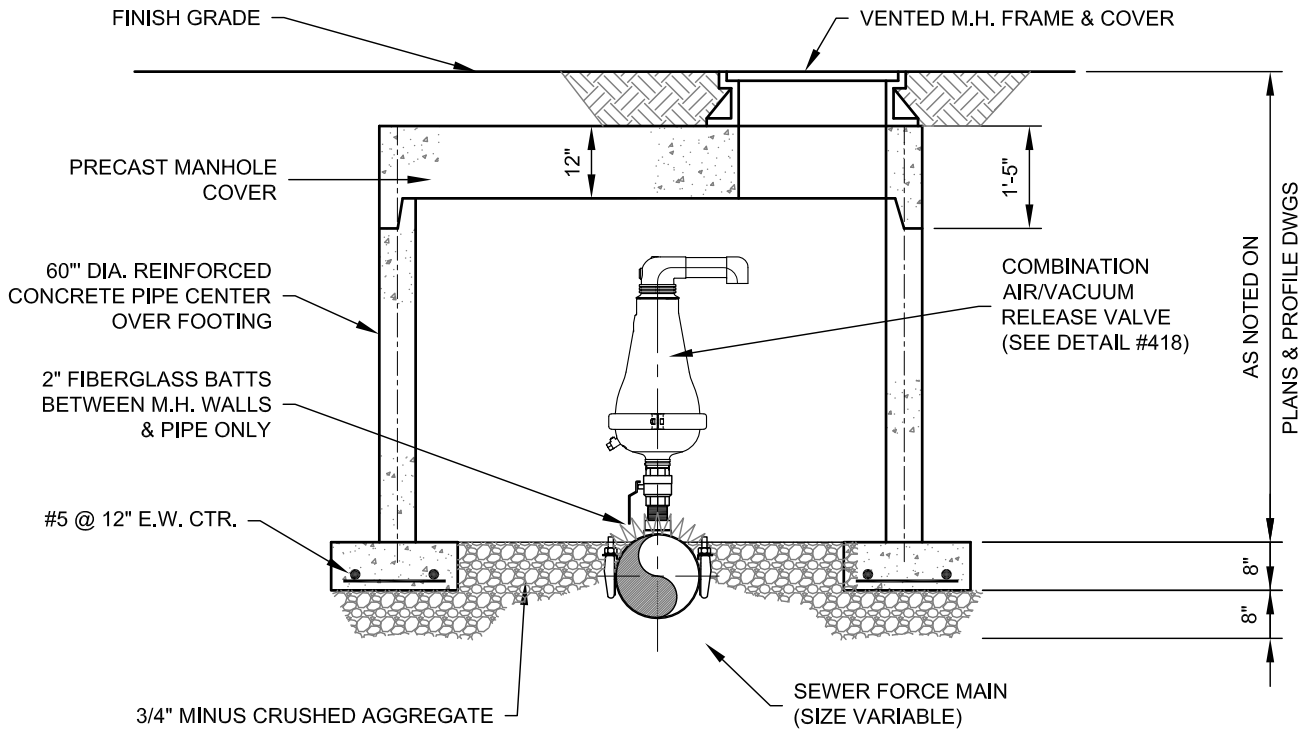

SECTION A

	Standard Details	Combination Air/Vaccum Sewer Release Valve Manhole	Scale: <u>N.T.S.</u>
	Wastewater Improvements		Detail No. 417

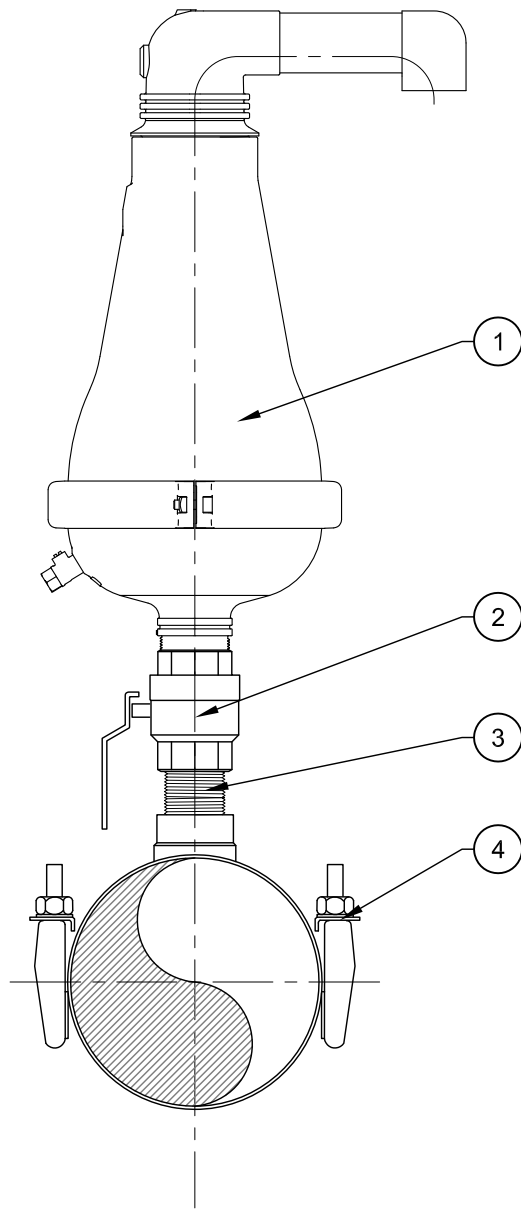

COMBINATION AIR/VACCUUM VALVE DETAIL TABLE		
ITEM NO.	SIZE AND DESCRIPTION	MATERIAL SPECIFICATIONS
①	COMBINATION AIR/VACCUUM VALVE	A.R.I. D-025 OR ENGINEERED APPROVED EQUAL.
②	2" BALL VALVE	2" 316 STAINLESS STEEL THREADED BALL VALVE.
③	2" NIPPLE	2" 316 STAINLESS STEEL NIPPLE. USE TEFLON TAPE.
④	2" x MAIN SIZE SADDLE	FORD FS323-***-IP7 STAINLESS STEEL SADDLE OR ENGINEER APPROVED EQUAL. DIP PIPE MAIN TO BE TAPPED AND THREADED.



Standard Details
Wastewater Improvements

Combination Air/Vacuum Sewer Release Valve

Scale: N.T.S.
Detail No.
418

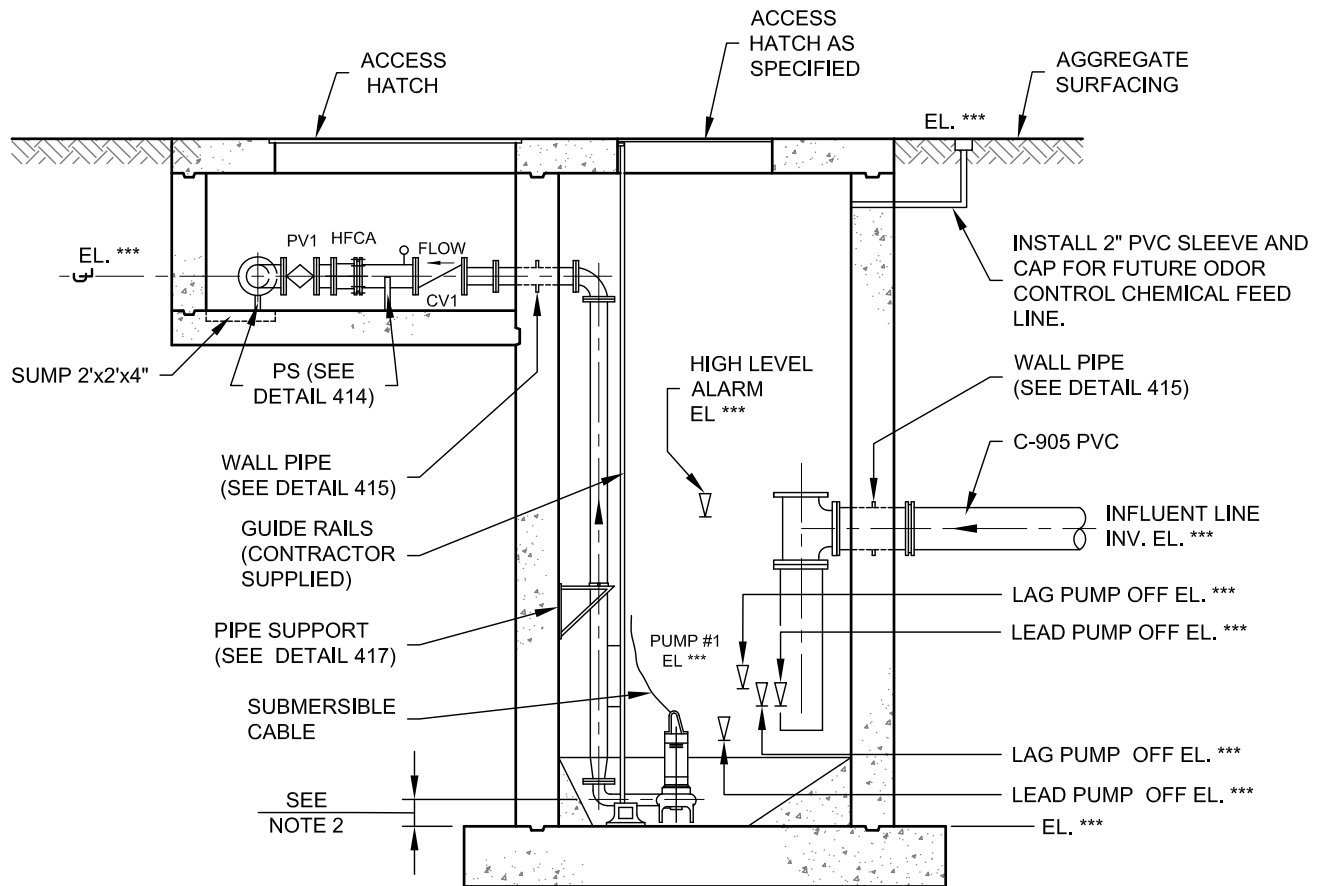

SECTION A

NOTES:

1. COATING SHALL BE APPLIED TO INTERIOR OF WET WELL AS PER LAKE HAVASU CITY STANDARD SPECIFICATIONS.
2. PROVIDE CLEARANCE BETWEEN FLOOR AND PUMP SUCTION AS RECOMMENDED BY MANUFACTURER.

ABBREVIATIONS:

- | | |
|------|------------------------------------|
| PV1 | PLUG VALVE |
| CV1 | CHECK VALVE |
| PS | PIPE SUPPORT |
| EL | ELEVATION |
| HFCA | HARNESSED FLANGED COUPLING ADAPTER |

	Standard Details	Pump Station Section	Scale: <u>N.T.S.</u>
	Wastewater Improvements		Detail No. 419

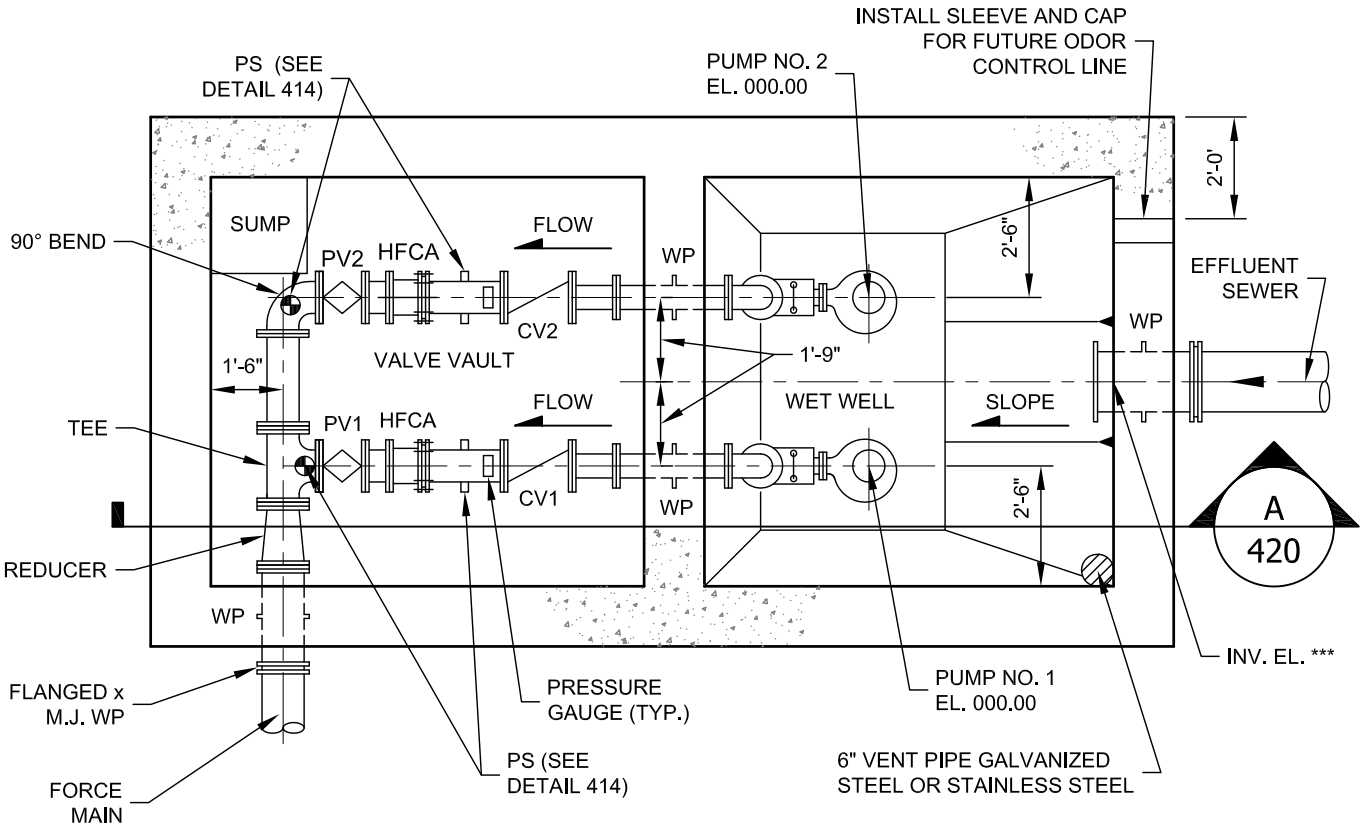

PLAN VIEW

NOTES:

1. COATING SHALL BE APPLIED TO INTERIOR OF WET WELL AS PER LAKE HAVASU CITY STANDARD SPECIFICATIONS.
2. PROVIDE CLEARANCE BETWEEN FLOOR AND PUMP SUCTION AS RECOMMENDED BY MANUFACTURER.

ABBREVIATIONS:

- | | |
|------|------------------------------------|
| PV1 | PLUG VALVE |
| CV1 | CHECK VALVE |
| PS | PIPE SUPPORT |
| EL | ELEVATION |
| HFCA | HARNESSED FLANGED COUPLING ADAPTER |
| WP | WALL PIPE |

 LAKE HAVASU CITY	Standard Details	Pump Station Plan View	Scale: <u>N.T.S.</u>
	Wastewater Improvements		Detail No. 420

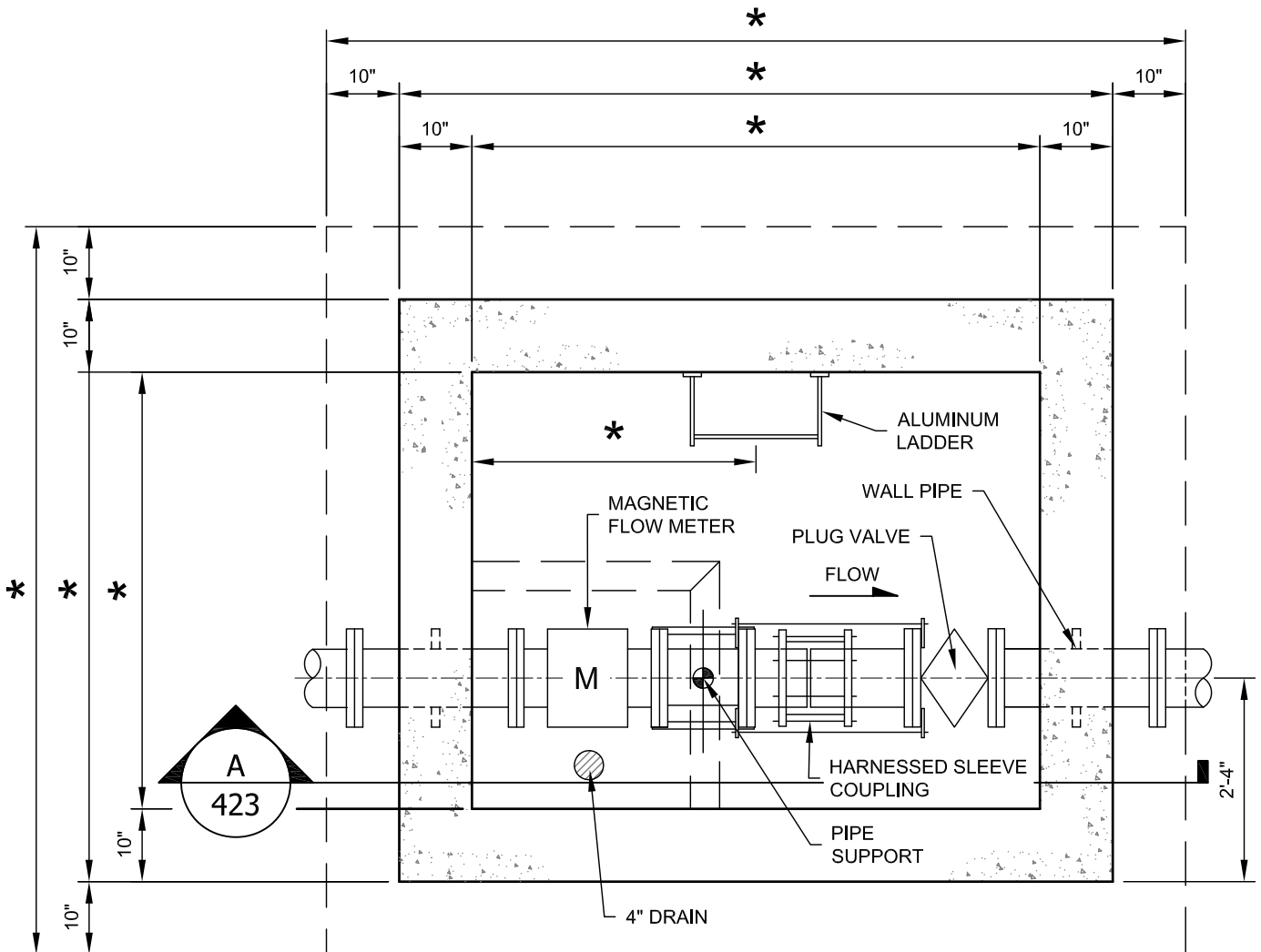

BASE SLAB PLAN

NOTE:

* DIMENSION TO BE PROJECT SPECIFIC.

	Standard Details	Force Main Meter Vault Base Slab Plan	Scale: <u>N.T.S.</u>
	Wastewater Improvements		Detail No. 421

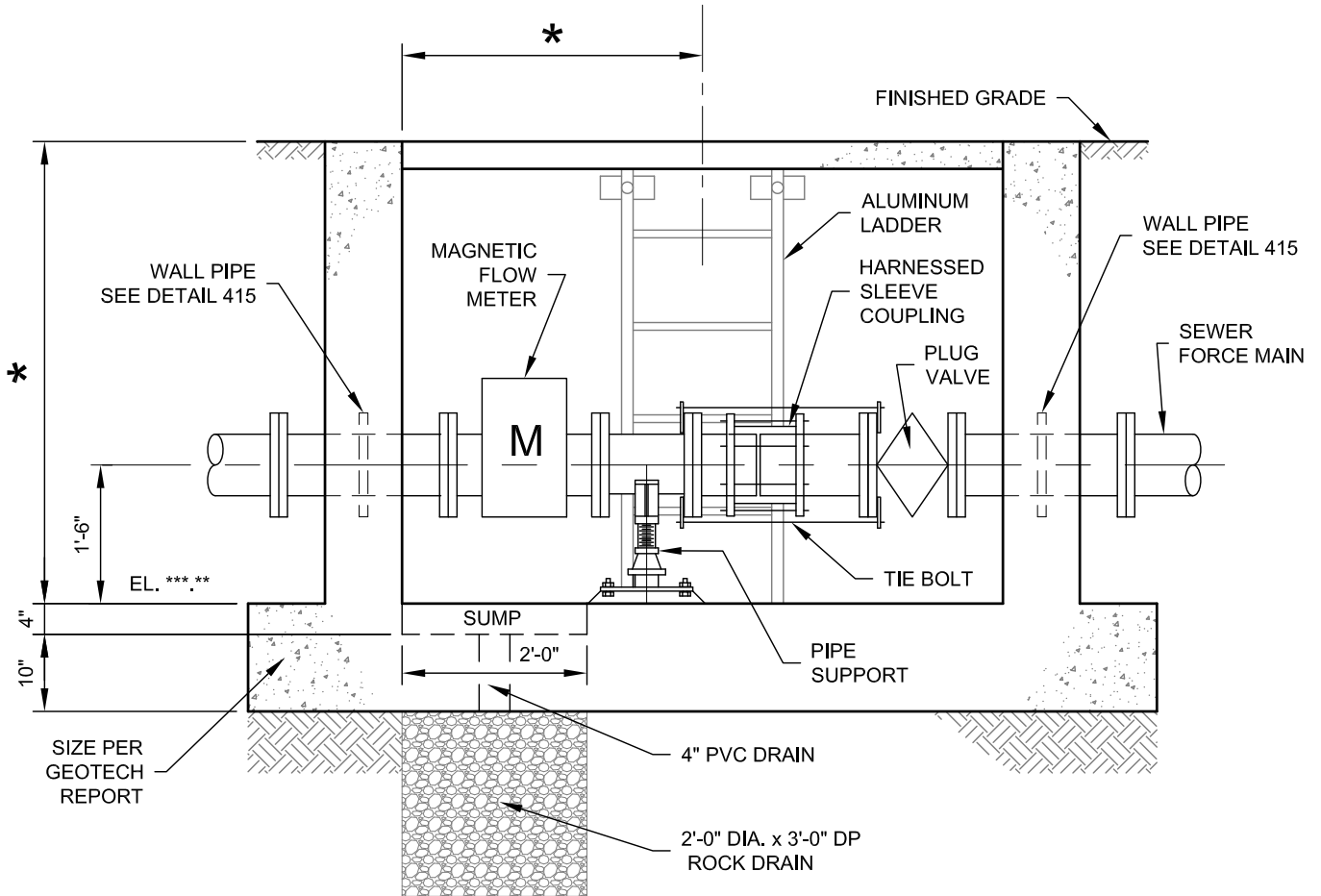

SECTION A

NOTE:

* DIMENSION TO BE PROJECT SPECIFIC.

	Standard Details	Force Main Meter Vault Section	Scale: <u>N.T.S.</u>
	Wastewater Improvements		Detail No. 422

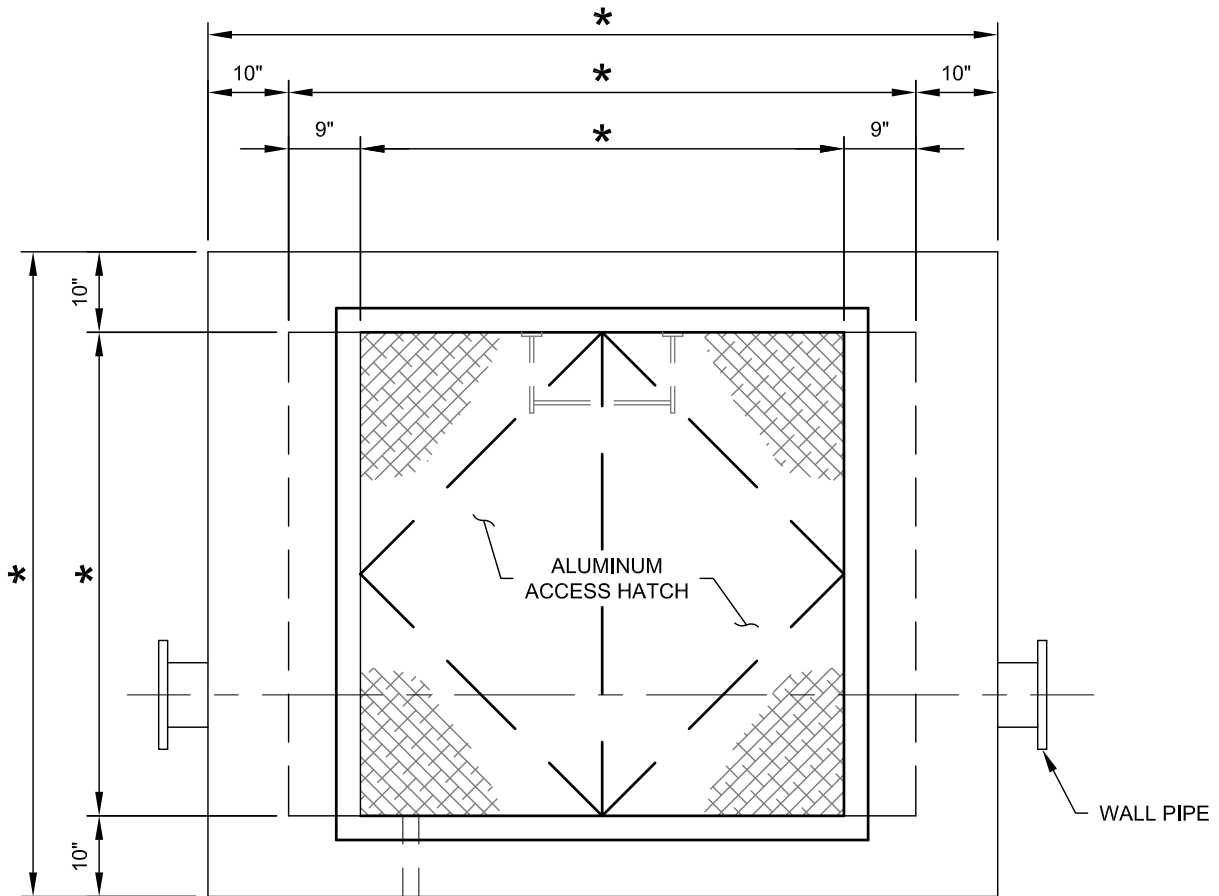

TOP SLAB PLAN

NOTE:

* DIMENSION TO BE PROJECT SPECIFIC.

	<p>Standard Details</p>	<p>Force Main Meter Vault Top Slab Plan</p>	<p>Scale: <u>N.T.S.</u></p>
	<p>Wastewater Improvements</p>		<p>Detail No. 423</p>

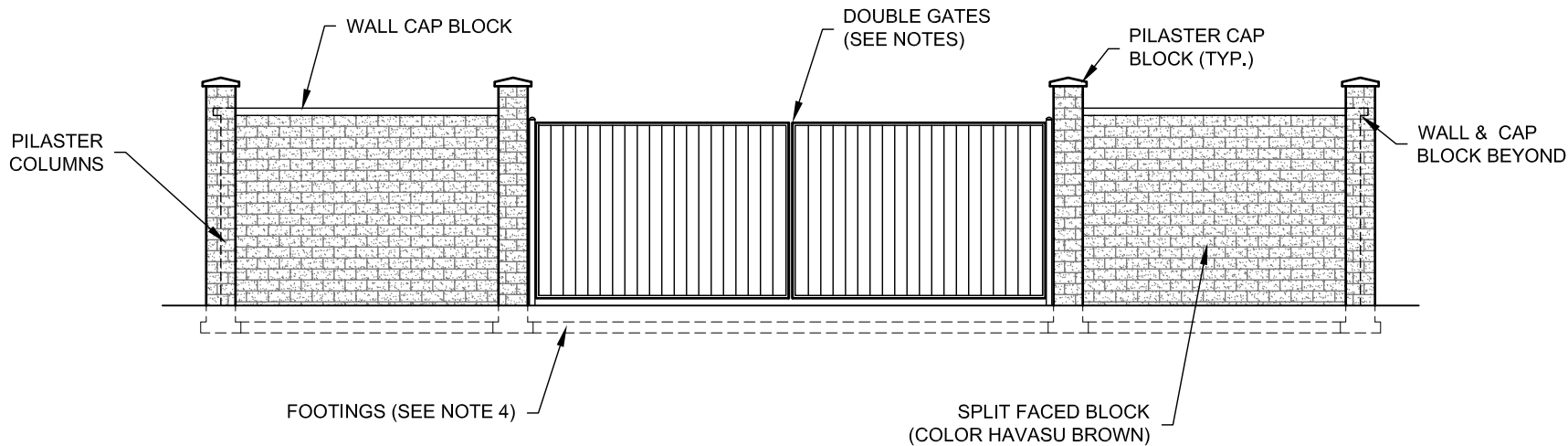

NOTES:

1. PROVIDE TWO SWINGING GATE SECTIONS, EACH 8' HIGH GATE SECTIONS TO BE ROHN PRIVACY PANELING @ 1-800-447-2264. PANELS TO BE VERTICAL ROLL-FORMED .017 GRADE E STEEL. HORIZONTAL RAILS ARE 1 1/4" x 1 1/2", .074 MINIMUM STEEL. SIZE POSTS AS REQUIRED.
2. PROVIDE LOCKING SYSTEM AS STANDARD OF MANUFACTURER. ALL MATERIALS TO BE FINISHED WITH G-60 & G-90 GALVANIZING (AS STANDARD OF MANUFACTURER) AND DURANAR HIGH PERFORMANCE FLUOROCARBON OVEN-BAKED COLOR COATING GALVANIZED SURFACES.
3. REPRESENTATIVE FROM MANUFACTURER'S STANDARD COLORS. MANUFACTURER TO PROVIDE FIELD TOUCH-UP PAINT AND ALL ACCESSORIES REQUIRED.
4. ALL FOOTINGS TO BE ENGINEERED BY OTHERS.

	Standard Details	Typical Pump Station CMU Screened Wall	Scale: <u>N.T.S.</u>
	Wastewater Improvements		Detail No. 424

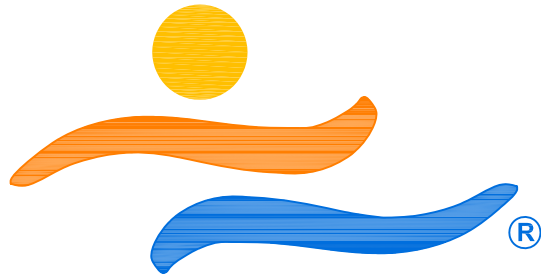

LAKE HAVASU CITY

**STORMWATER
IMPROVEMENTS**

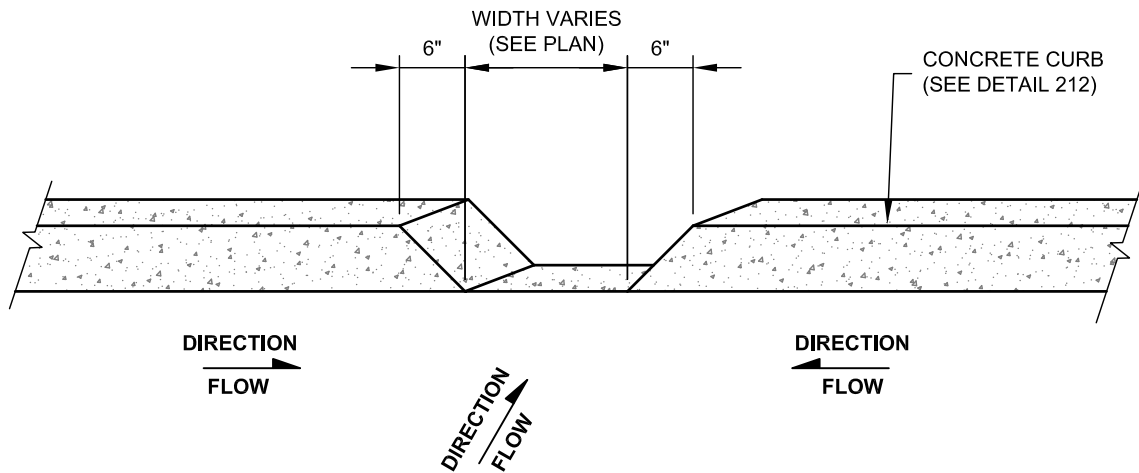

Standard Details

Stormwater Improvements

Depressed Curb Opening

Scale: N.T.S.

Detail No.

500

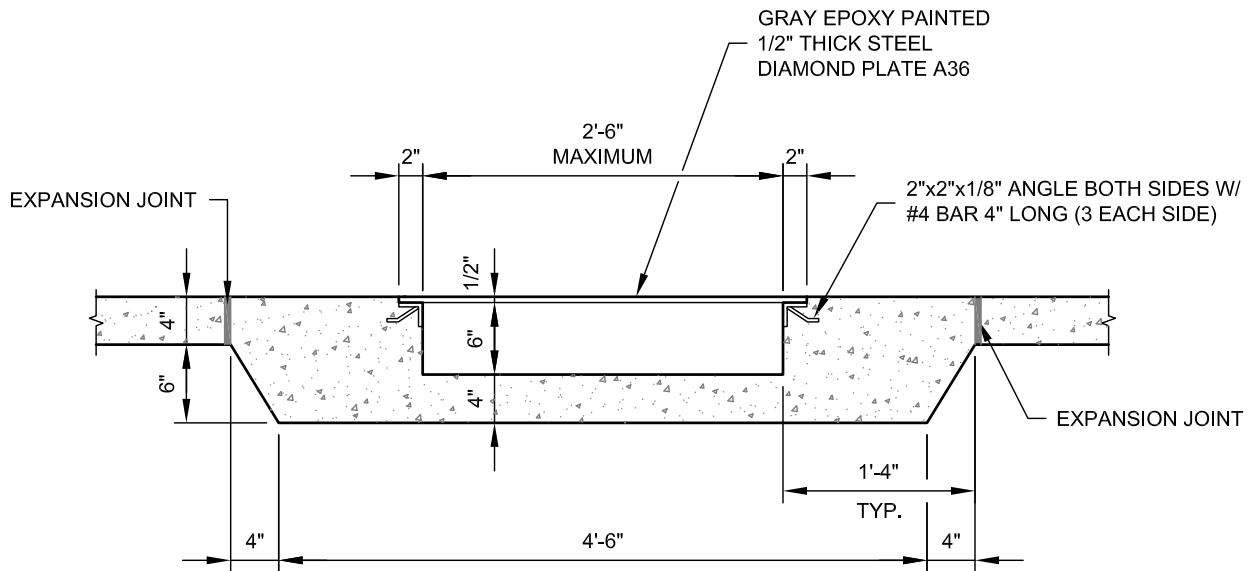

NOTE:

1. CONCRETE TO BE CLASS 'AA' (4000 PSI).

	Standard Details	Scuppers	Scale: <u>N.T.S.</u>
	Stormwater Improvements		Detail No. 501

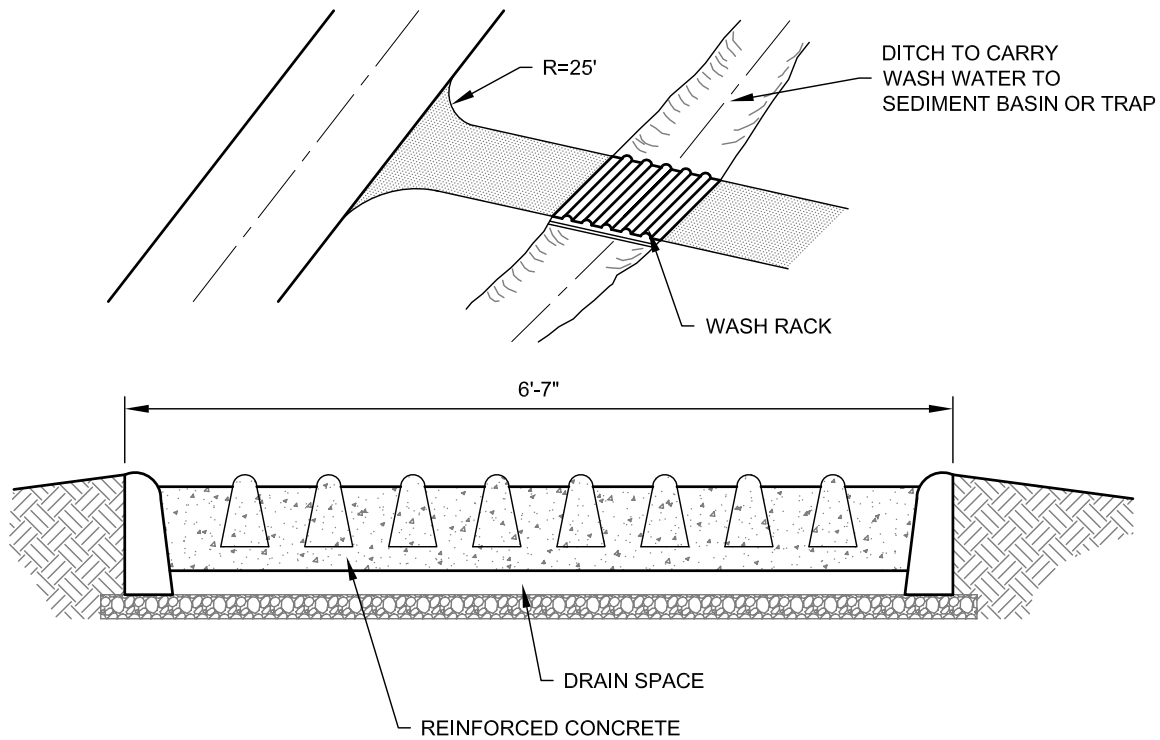

WASH RACK

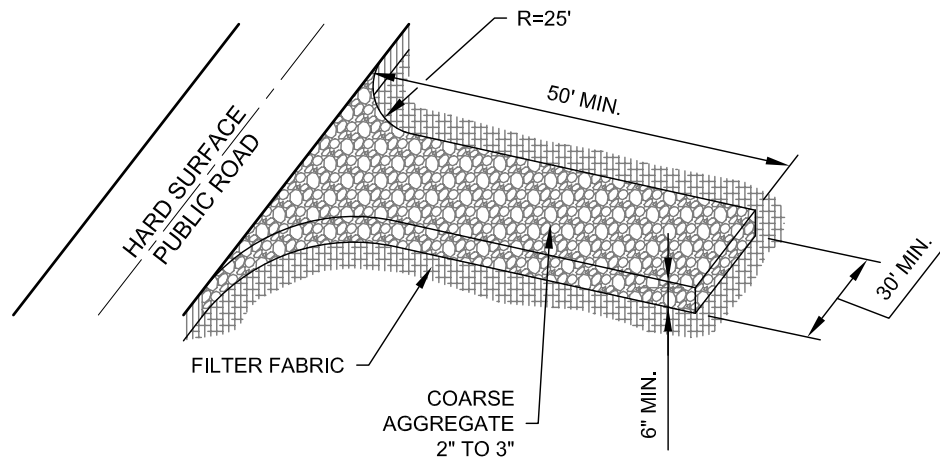

STABILIZED CONSTRUCTION ENTRANCE

NOTES:

1. PUT SILT FENCE OR TREE PROTECTION FENCE UP TO ENSURE CONSTRUCTION ENTRANCE IS USED.
2. IF CONSTRUCTION ON THE SITES ARE SUCH THAT THE MUD IS NOT REMOVED BY THE VEHICLE TRAVELING OVER THE STONE, THEN THE TIRES OF THE VEHICLE MUST BE WASHED BEFORE ENTERING THE PUBLIC ROAD.
3. IF A PROJECT CONTINUES TO PULL MUD AND DEBRIS ON TO THE PUBLIC ROAD, THE GOVERNING AUTHORITY WILL CLEAN THE AREA AND INVOICE THE FINANCIALLY RESPONSIBLE PERSON AS INDICATED ON THE FINANCIAL RESPONSIBILITY FORM.

	Standard Details	Stabilized Construction Entrance (Commercial)	Scale: <u>N.T.S.</u>
	Stormwater Improvements		Detail No. 502A

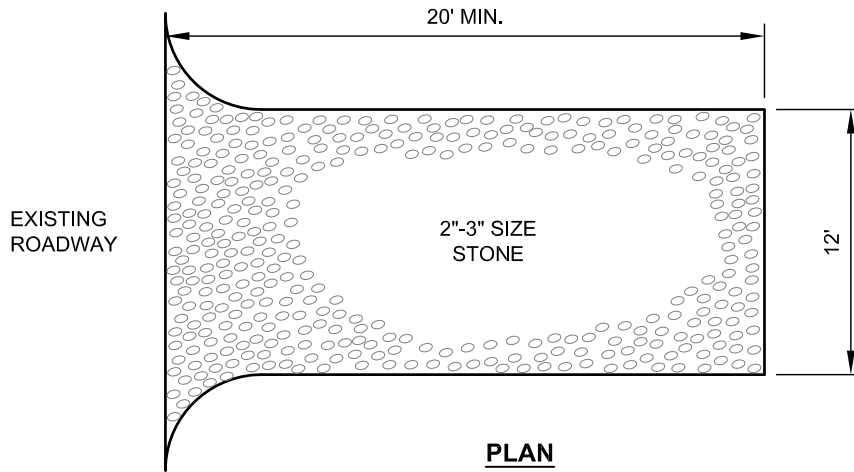

FABRIC MAY BE ADDED UNDER THE STONE WHICH WOULD ADD TOTAL LIFE TO THE CONSTRUCTION ENTRANCE.

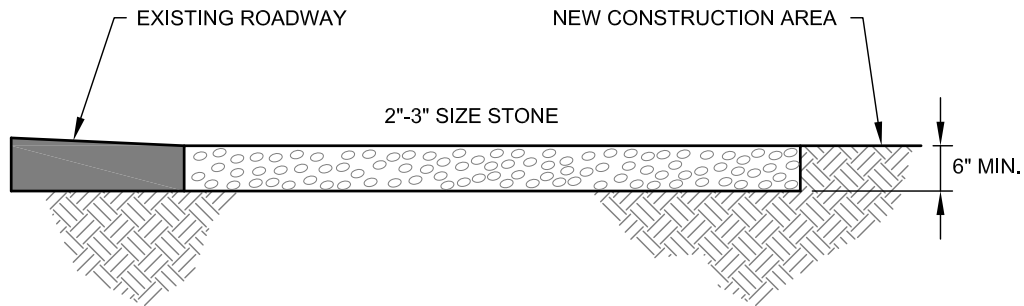

CROSS SECTION

NOTE:

1. THIS ENTRANCE APPLIES ONLY TO ENTRANCES OF INDIVIDUAL SINGLE FAMILY RESIDENTIAL UNITS.
2. PUT SILT FENCE OR WATTLE PROTECTION UP TO ENSURE CONSTRUCTION ENTRANCE IS USED.
3. CONSTRUCTION ENTRANCES SHOULD BE LOCATED ON THE SIDE OF THE PROPERTY WHERE FUTURE DRIVEWAYS ARE TO BE LOCATED. PROTECT ALL CURBS FROM DAMAGE WITH CURB RAMPS.
4. IF CONSTRUCTION ON THE SITES ARE SUCH THAT THE MUD IS NOT REMOVED BY THE VEHICLE TRAVELING OVER THE STONE, THEN THE TIRES OF THE VEHICLE MUST BE WASHED BEFORE ENTERING THE PUBLIC ROAD.
5. IF A PROJECT CONTINUES TO PULL MUD AND DEBRIS ON TO THE PUBLIC ROAD, THE GOVERNING AUTHORITY WILL CLEAN THE AREA AND INVOICE THE FINANCIALLY RESPONSIBLE PARTY.

	Standard Details	Stabilized Construction Entrance (Residential)	Scale: <u>N.T.S.</u>
	Stormwater Improvements		Detail No. 502B

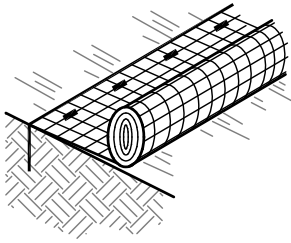

ANCHOR SLOT: BURY THE UP-CHANNEL END OF THE NET IN A 12" DEEP TRENCH. TAMP THE SOIL FIRMLY. STAPLE AT 12" INTERVALS ACROSS THE NET.

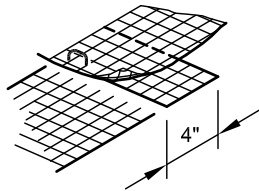

OVERLAP: OVERLAP EDGES OF THE STRIPS AT LEAST 4". STAPLE EVERY 12" DOWN THE CENTER OF THE STRIP.

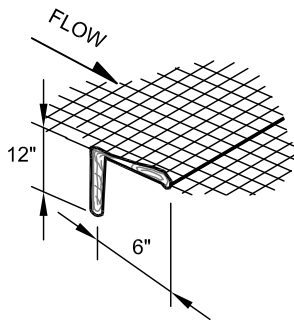

JOINING STRIPS: INSERT THE NEW ROLL OR NET IN A TRENCH, AS WITH THE ANCHOR SLOT. OVERLAP THE UP-CHANNEL END OF THE PREVIOUS ROLL 18" AND TURN THE END OF THE PREVIOUS ROLL, JUST BELOW THE ANCHOR SLOT, LEAVING 6" OVERLAP.

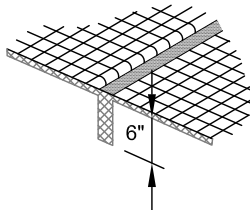

CHECK SLOTS: ON ERODIBLE SOILS OR STEEP SLOPES, CHECK SLOTS SHOULD BE MADE EVERY 15 FEET. INSERT A FOLD OF THE NET INTO A 6" TRENCH AND TRAMP FIRMLY. STAPLE AT 12" INTERVALS ACROSS THE NET. LAY THE NET SMOOTHLY ON THE SURFACE OF THE SOIL - DO NOT STRETCH THE NET, AND DO NOT ALLOW WRINKLES.

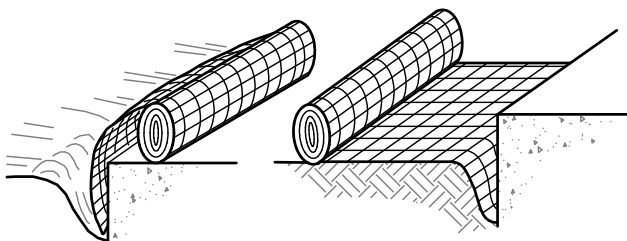

ANCHORING ENDS AT STRUCTURES: PLACE THE END OF THE NET IN A 12" SLOT ON THE UP-CHANNEL SIDE OF THE STRUCTURE. FILL THE TRENCH AND TAMP FIRMLY. ROLL THE NET UP THE CHANNEL. PLACE STAPLES AT 12" INTERVALS ALONG THE ANCHOR END OF THE NET.

	Standard Details	Installation of Erosion Control Mats	Scale: <u>N.T.S.</u>
	Stormwater Improvements		Detail No. 503

NOTES:

1. INSTALL SEDIMENT WATTLES AS SLOPES ARE CONSTRUCTED TO GRADE OR AS DIRECTED BY ENGINEER. SELECT, INSTALL AND MAINTAIN IN CONFORMANCE WITH MFG'S SPECIFICATIONS TO MEET SITE CONDITIONS FOR SLOPE PROTECTION AND IN ACCORDANCE WITH GOOD ENGINEERING PRACTICES. NO SEDIMENT WATTLES SHALL BE INSTALLED IN URBAN FREEWAY MEDIANS, NOR WHERE CABLE BARRIER SYSTEMS ARE INSTALLED.
2. SEDIMENT WATTLES SHALL BE IN CONTINUOUS CONTACT WITH TRENCH BOTTOM AND SIDES. DO NOT OVERLAP WATTLES ENDS ON TOP OF EACH OTHER. A 20" DIA. WATTLE MAY BE MADE FROM 2-3 ROLLED EXCELSIOR OR STRAW BLANKETS.
3. BUTT ADJOINING WATTLES TIGHTLY AGAINST EACH OTHER. DRIVE FIRST END STAKE OF THE SECOND WATTLE AT THE ANGLE TOWARD THE FIRST WATTLE TO HELP ABUT THEM TIGHTLY.
4. REPAIR ANY RILLS OR GULLIES PROMPTLY. FIELD ADJUST AND CORRECT WATTLE BMP IMMEDIATELY IF IT IS CAUSING FLOODING, EROSION, AND/OR AFFECTING ROADWAY SAFETY.
5. CONSTRUCTION OF CUT SLOPES 2:1 AND STEEPER IN SOIL AND ROCK MATERIALS THAT CAN BE RIPPED SHALL BE CONSTRUCTED, WHENEVER POSSIBLE, BY MINIBENCHING. REFER TO SLOPE MINIBENCHING DETAIL.
6. LOOSENING SURFACE SOIL IS NOT REQUIRED WHERE MINIBENCHES ARE USED. FOR SEEDED AREAS, TILLAGE SHALL BE PERFORMED TO FORM MINOR RIDGES AND FURROWS PARALLEL TO NEW SLOPES CONTOURS AND AS SPECIFIED IN SECTION 805 OF THE STANDARDS SPECIFICATIONS.
7. DIVERT AND DIRECT RUN-ON WATER FROM OUTSIDE OF THE SLOPES TO THE SPILLWAYS AND/OR ROCK RIPRAP/ROCK MULCH. DIVERSION DIKES AND/OR DITCHES ARE NECESSARY ON NATURAL UNDISTURBED SLOPES BEYOND THE TOP LIMITS OF NEW SLOPES TO DIVERT RUN-ON WATER.
8. INSTALLATION AND MAINTENANCE OF SEDIMENT WATTLE BMP'S SHALL NOT NEGATIVELY IMPACT TRAFFIC SAFETY, NOR THE DESIGNED FUNCTION OF THE ROADWAY OR BRIDGE DRAINAGE FACILITIES.
9. INSTALL AND MAINTAIN SEDIMENT WATTLE BMP'S TO CARRY THE STORMWATER OF AT LEAST 2-YEA, 24 HOUR EVENTS.
10. THE SEDIMENT WATTLE BMP'S PAY/BID ITEM SHALL INCLUDE ALL MATERIALS USED FOR THIS BMP: ALL GROUND PREPARATION, FURNISHING, INSTALLING, MAINTENANCE, FINAL REMOVAL, AND DISPOSAL OF THIS TEMPORARY BMP, AS WELL AS RETURNING THE AREA TO AN ACCEPTABLE CONDITION AS APPROVED BY THE ENGINEER.
11. REFER TO STANDARD SPECIFICATION SECTION 810-2.06(C) FOR SEDIMENT WATTLE MATERIAL SPECIFICATIONS.
12. MAKE FIELD ADJUSTMENTS AND CORRECTIONS TO ENSURE NO SENSITIVE BIOLOGICAL RESOURCE (NATIVE SPECIES/ HABITATS) WILL BE ADVERSELY IMPACTED.

	Standard Details	Wattle Notes	Scale: <u>N.T.S.</u>
	Stormwater Improvements		Detail No. 504A

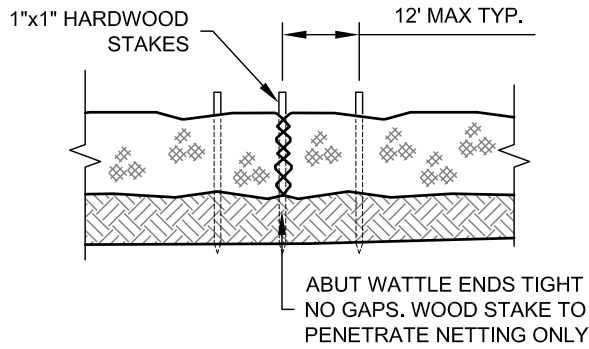

SEDIMENT WATTLE OVERLAP

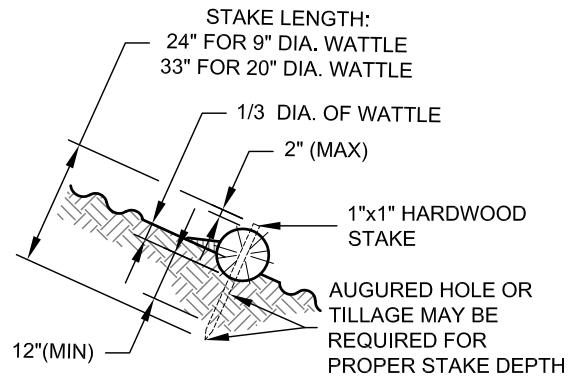

SEDIMENT WATTLE STAKING

EXCAVATED MATERIAL TO BE TAMPED AGAINST UPSTREAM SIDE OF THE SEDIMENT WATTLES TO PREVENT UNDERMINING. THE THICKNESS SHOULD BE NO MORE THAN 2" TO AVOID DRAMATIC REDUCTION OF THE SEDIMENT LOADING CAPACITY.

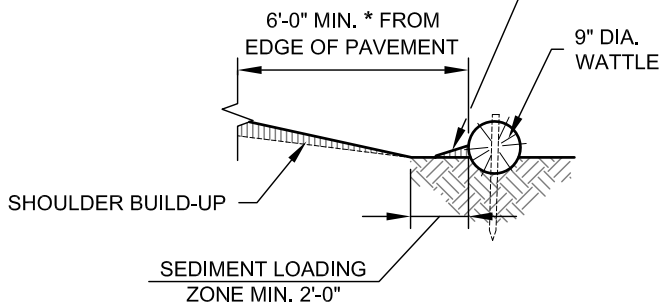

NEW SHOULDER ** BUILDUP PROTECTION

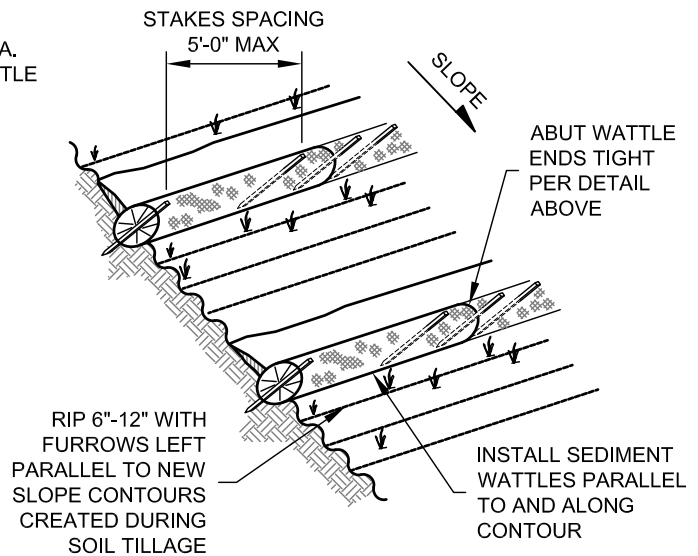

SEDIMENT WATTLE LAYOUT

**** NOTE:**
 APPLICABLE ONLY IN THE AREAS OF CONCENTRATED FLOW - TO INCLUDE BUT NOT BE LIMITED TO ROADWAY SAG SPOTS AND DROP-OFF REPAIR LOCATIONS AS PER THE DIRECTION OF THE ENGINEER.

	Standard Details	Wattle Detail	Scale: <u>N.T.S.</u>
	Stormwater Improvements		Detail No. 504B

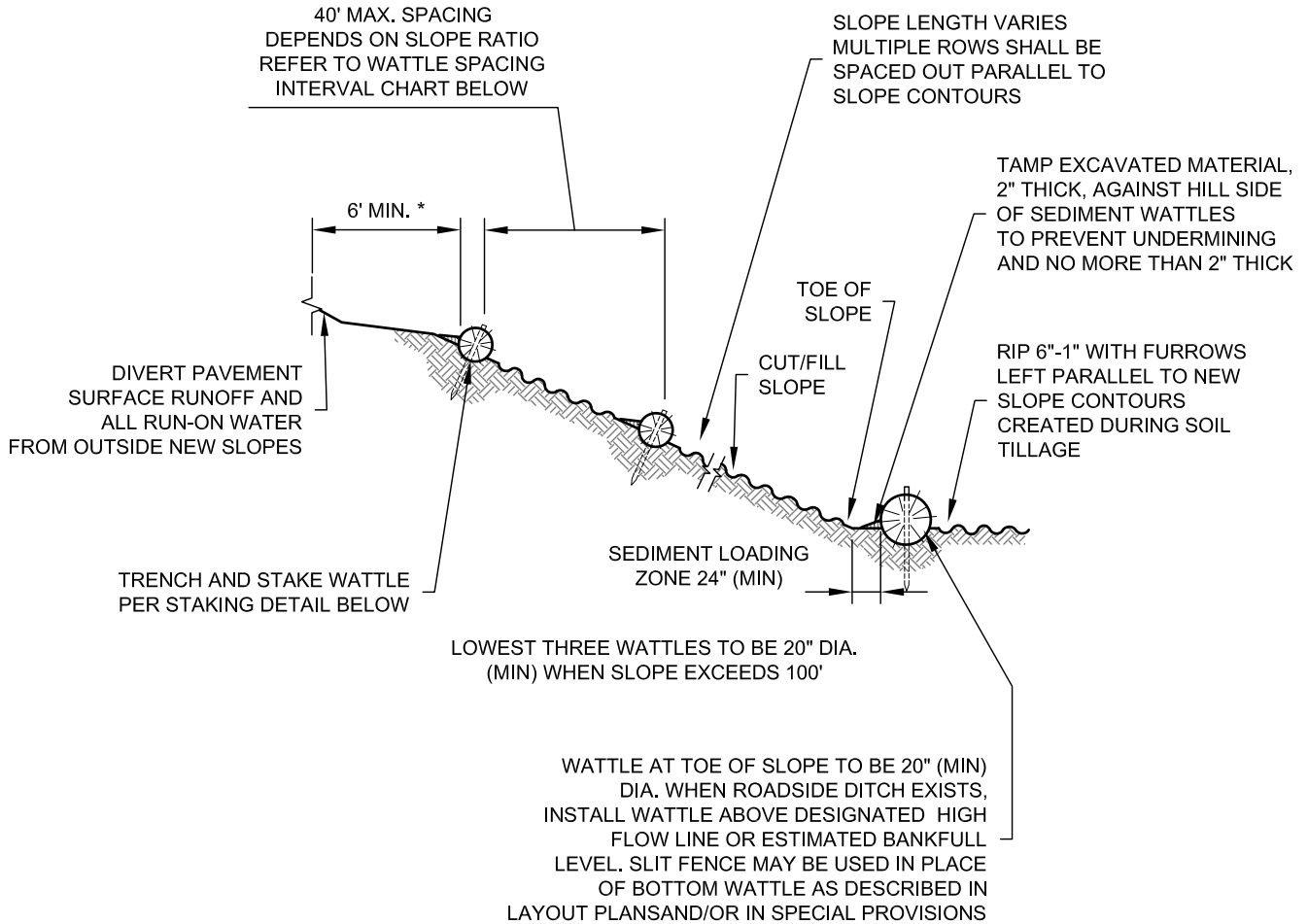

SEDIMENT WATTLE SECTION

*** NOTE:**

TOP ROW SHALL NOT BE PLACED WITHIN 6'-0" OF EDGE OF PAVEMENT AND 9'-0" FROM OUTSIDE SURFACE OF BARRIER.

WATTLE SPACING INTERVALS	
SLOPE RATIO (H:V)	MAXIMUM SPACING INTERVALS
2:1	10'
3:1	20'
4:1	30'
5:1	40'
6:1	40'

	Standard Details	Wattle Section	Scale: <u>N.T.S.</u>
	Stormwater Improvements		Detail No. 504C

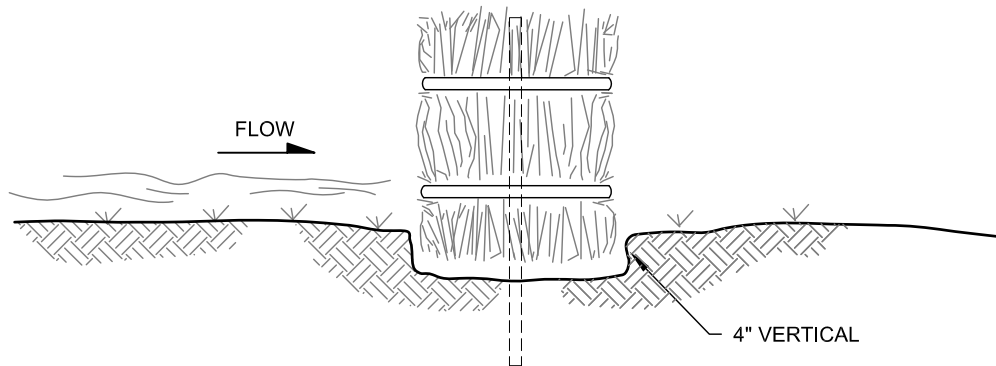

* PROMOTES ON SITE SEDIMENTATION
BY CREATING A TEMPORARY POND.

BEDDING DETAIL

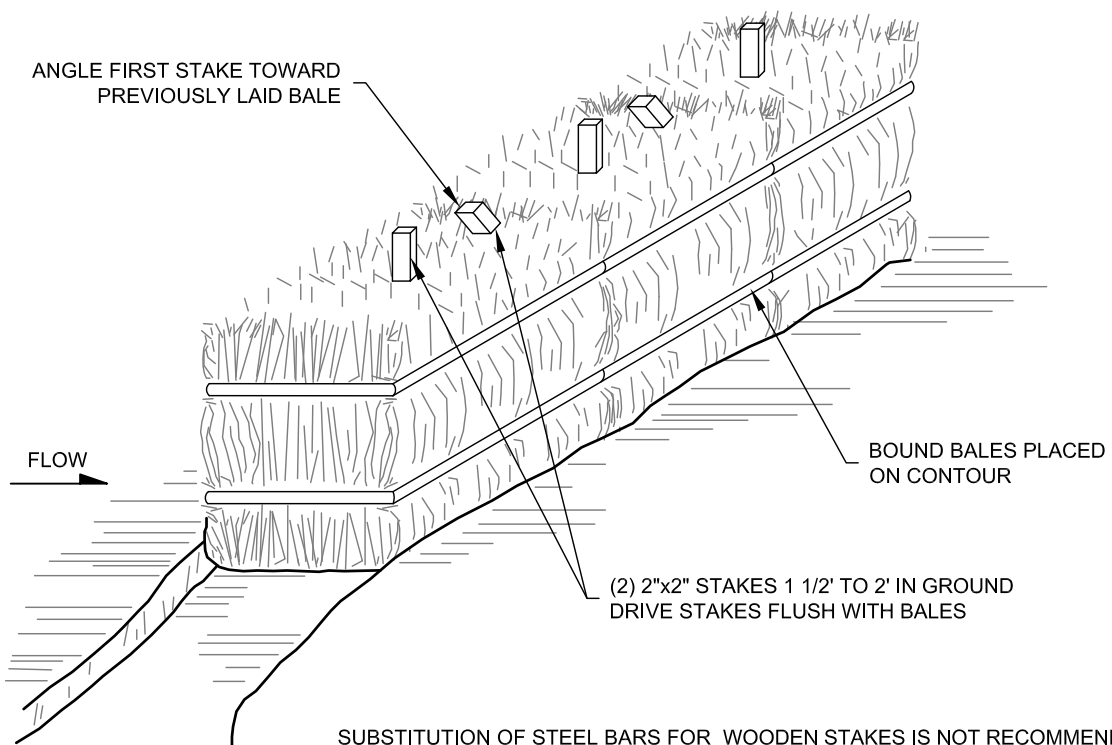

SUBSTITUTION OF STEEL BARS FOR WOODEN STAKES IS NOT RECOMMENDED
DUE TO POTENTIAL FOR DAMAGING CONSTRUCTION EQUIPMENT

ANCHORING DETAIL

	Standard Details	Organic Filter Barrier	Scale: <u>N.T.S.</u>
	Stormwater Improvements		Detail No. 505

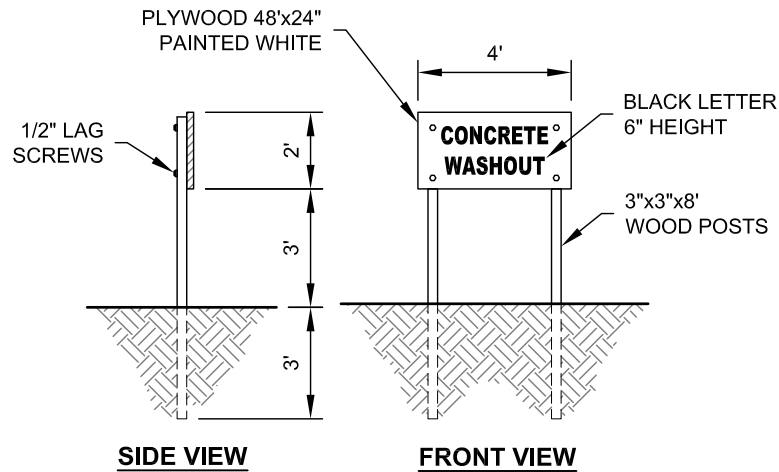

"CONCRETE WASHOUT" SIGN DETAILS

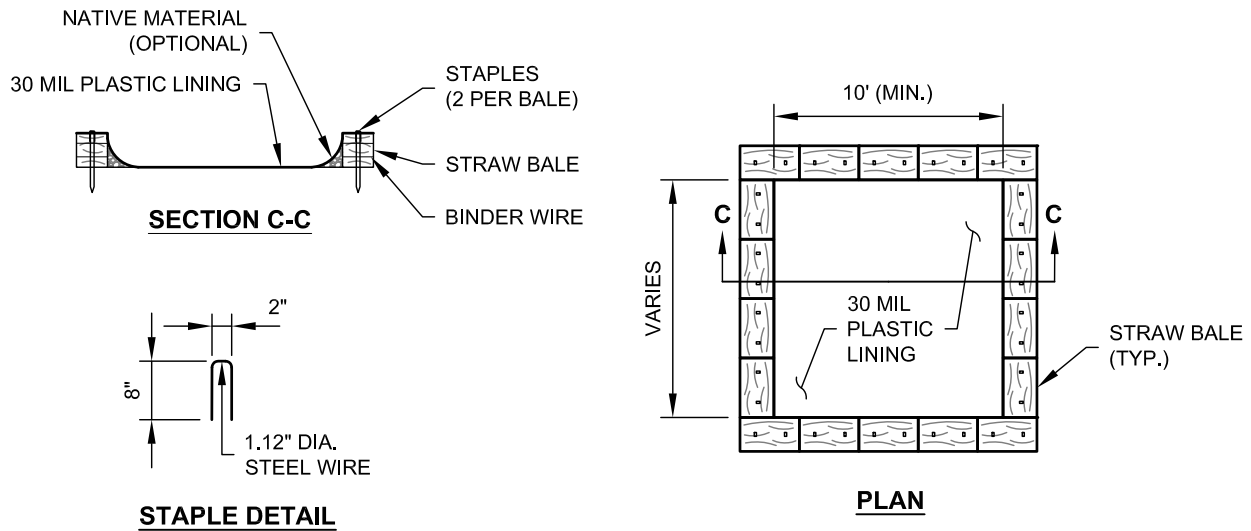

TYPE "ABOVE GRADE" WITH STRAW BALES

NOTE:

1. WASHOUTS AREAS FOR CONCRETE, PAINT OR STUCCO MUST BE LOCATE ON-SITE. LOCATE WASHOUT AREAS 50 FEET FROM DRAINS AND WATERCOURSES.
2. ACTUAL LAYOUT TO BE DETERMINED IN THE FIELD.
3. A CONCRETE WASHOUT SIGN SHALL BE INSTALLED WITHIN 30' OF THE TEMPORARY CONCRETE WASHOUT FACILITY.
4. LINING MATERIAL SHOULD BE A MINIMUM OF 30 MIL POLYETHYLENE SHEETING AND SHOULD BE FREE OF HOLES, TEARS, OPEN SEAMS OR OTHER DEFECTS THAT COMPROMISE THE IMPERMEABILITY OF THE MATERIAL.
5. MATERIALS USED TO CONSTRUCT TEMPORARY CONCRETE WASHOUT FACILITIES SHALL BE REMOVED FROM THE SITE OF THE WORK AND DISPOSED OF OR RECYCLED.
6. HOLES, DEPRESSIONS OR OTHER GROUND DISTURBANCE CAUSED BY THE REMOVAL OF THE TEMPORARY CONCRETE WASHOUT FACILITIES SHALL BE BACKFILLED, REPAIRED, AND STABILIZED TO PREVENT EROSION.

	Standard Details	Concrete Washout Straw Bales	Scale: <u>N.T.S.</u>
	Stormwater Improvements		Detail No. 506A

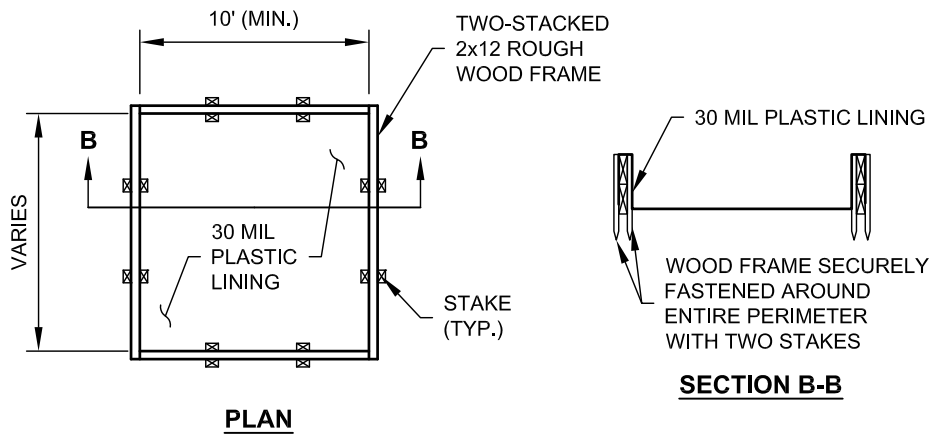

TYPE "ABOVE GROUND" WITH WOOD PLANKS

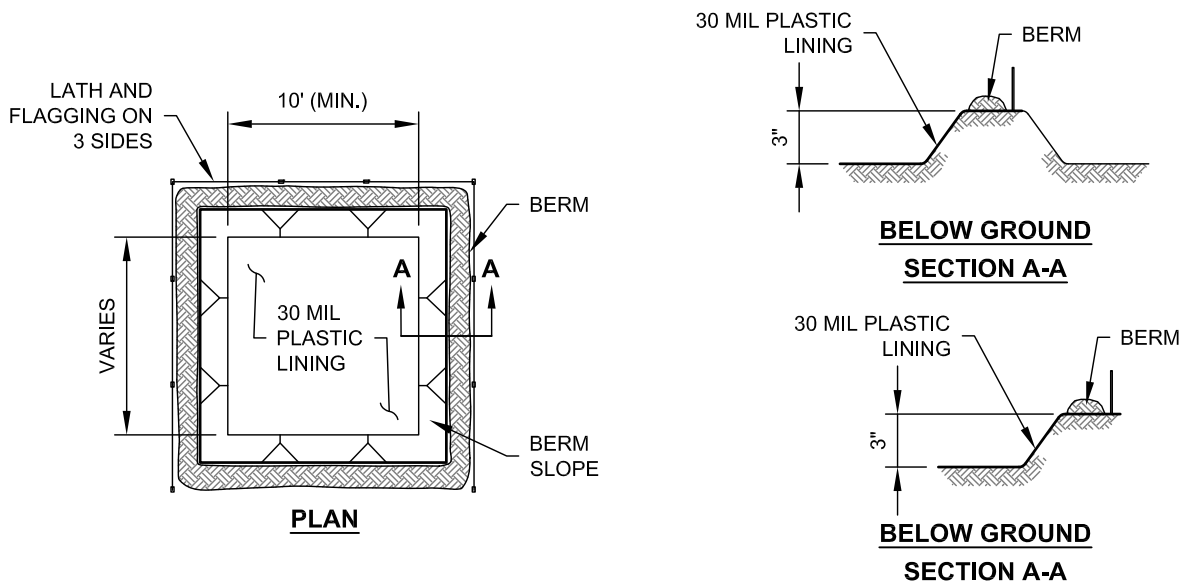

TYPE "BELOW & ABOVE GRADE"

NOTE:

1. WASHOUTS AREAS FOR CONCRETE, PAINT OR STUCCO MUST BE LOCATE ON-SITE. LOCATE WASHOUT AREAS 50 FEET FROM DRAINS AND WATERCOURSES.
2. ACTUAL LAYOUT TO BE DETERMINED IN THE FIELD.
3. A CONCRETE WASHOUT SIGN SHALL BE INSTALLED WITHIN 30' OF THE TEMPORARY CONCRETE WASHOUT FACILITY.
4. LINING MATERIAL SHOULD BE A MINIMUM OF 30 MIL POLYETHYLENE SHEETING AND SHOULD BE FREE OF HOLES, TEARS, OPEN SEAMS OR OTHER DEFECTS THAT COMPROMISE THE IMPERMEABILITY OF THE MATERIAL.
5. MATERIALS USED TO CONSTRUCT TEMPORARY CONCRETE WASHOUT FACILITIES SHALL BE REMOVED FROM THE SITE OF THE WORK AND DISPOSED OF OR RECYCLED.
6. HOLES, DEPRESSIONS OR OTHER GROUND DISTURBANCE CAUSED BY THE REMOVAL OF THE TEMPORARY CONCRETE WASHOUT FACILITIES SHALL BE BACKFILLED, REPAIRED, AND STABILIZED TO PREVENT EROSION.

	Standard Details	Concrete Washouts Wood Planks - Berms Below/Above	Scale: <u>N.T.S.</u>
	Stormwater Improvements		Detail No. 506B

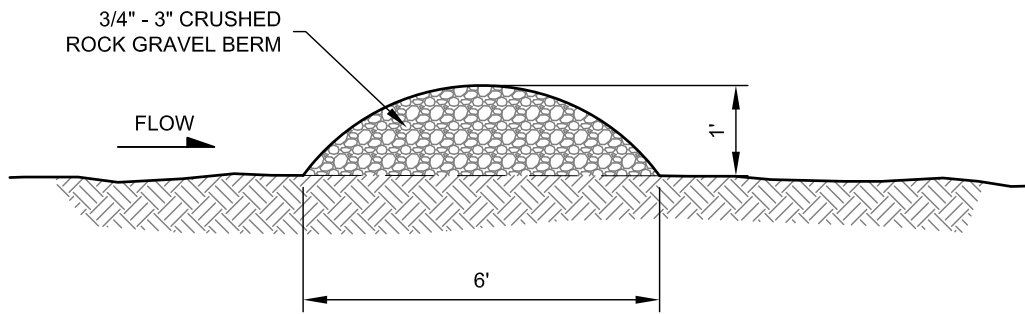

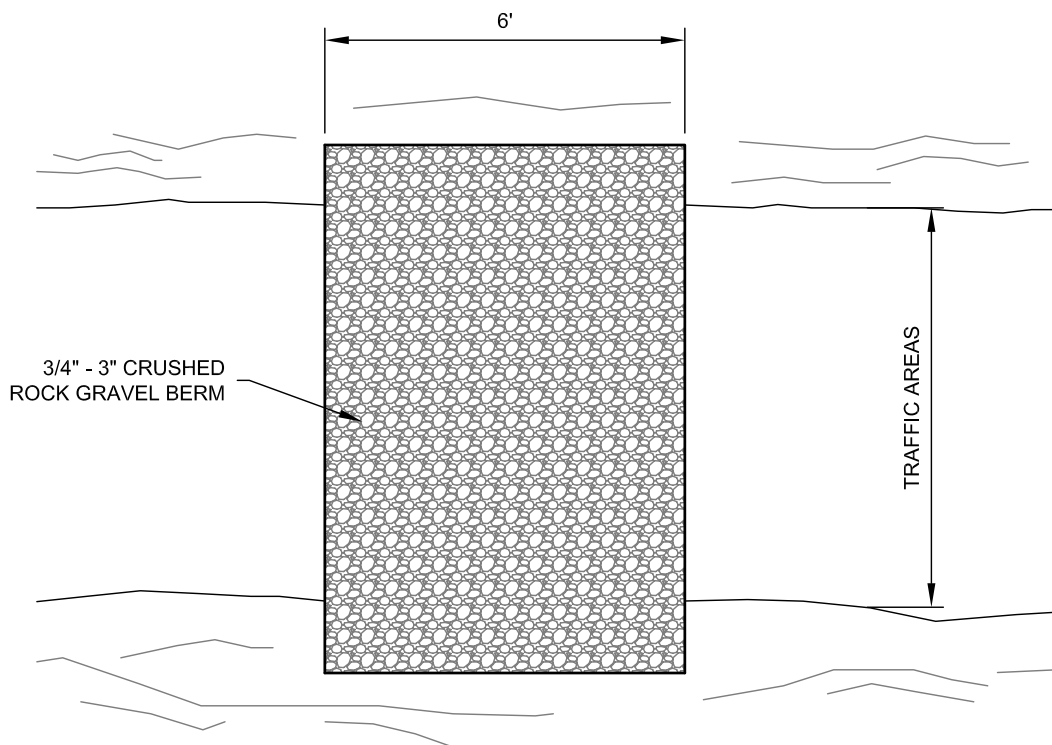

SECTION

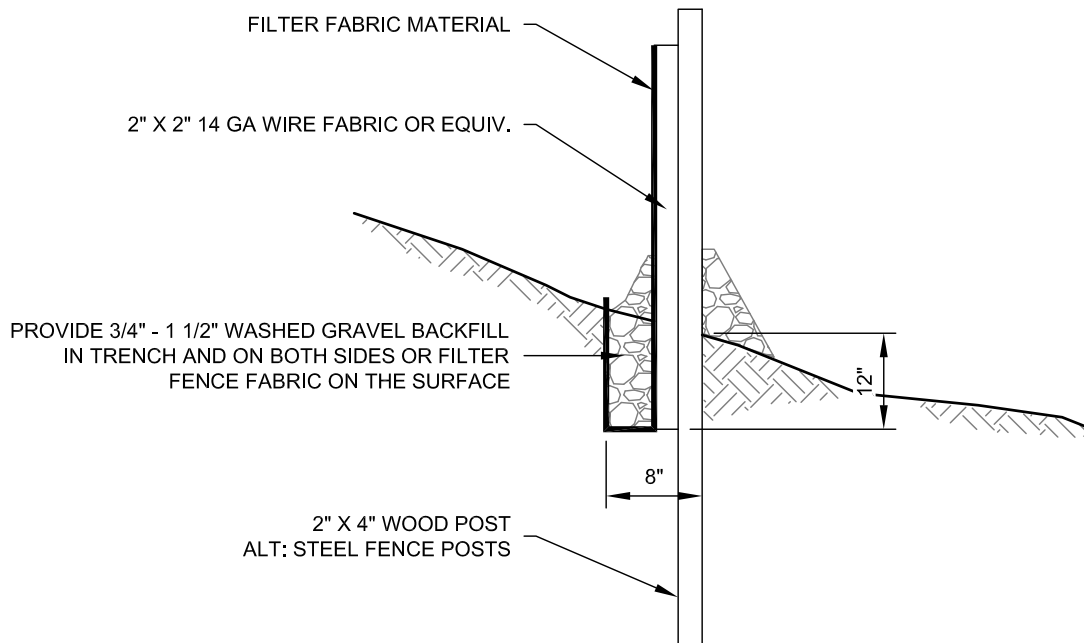
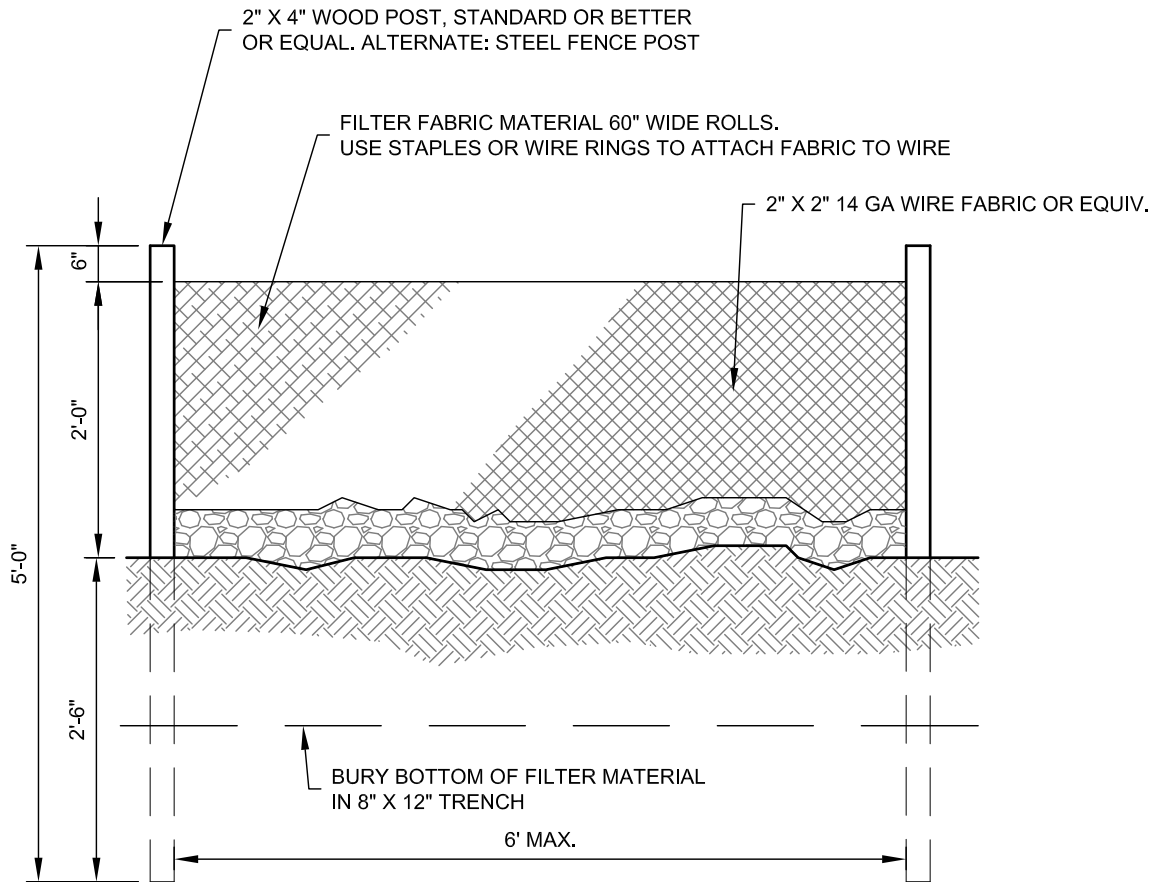

PLAN

	<p>Standard Details</p>	<p>Gravel Filter Berm (Traffic Areas)</p>	<p>Scale: <u>N.T.S.</u></p>
	<p>Stormwater Improvements</p>		<p>Detail No. 507</p>



	Standard Details	Silt Fence	Scale: <u>N.T.S.</u>
	Stormwater Improvements		Detail No. 508

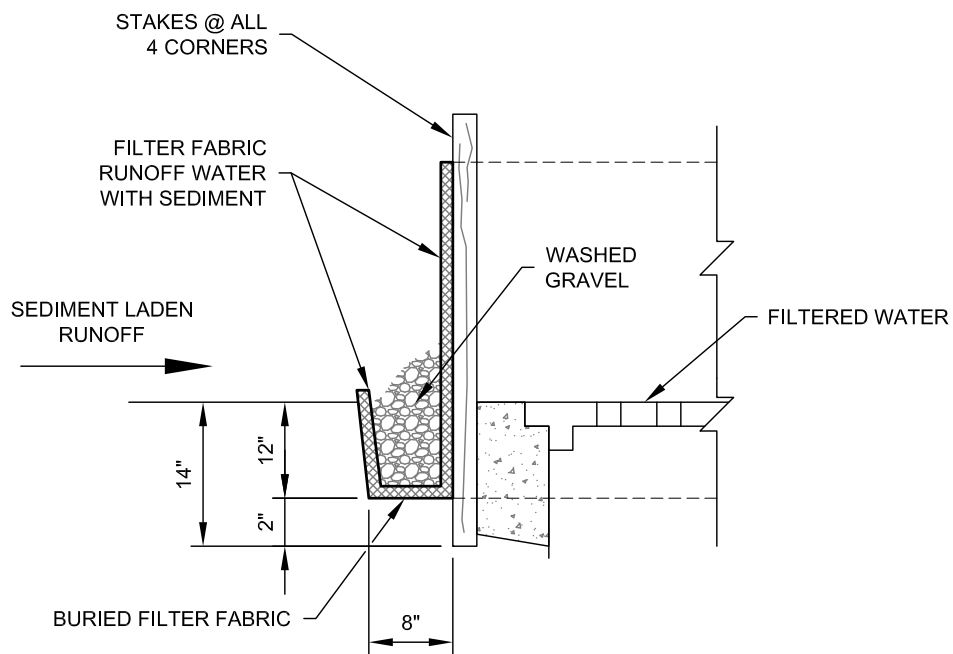
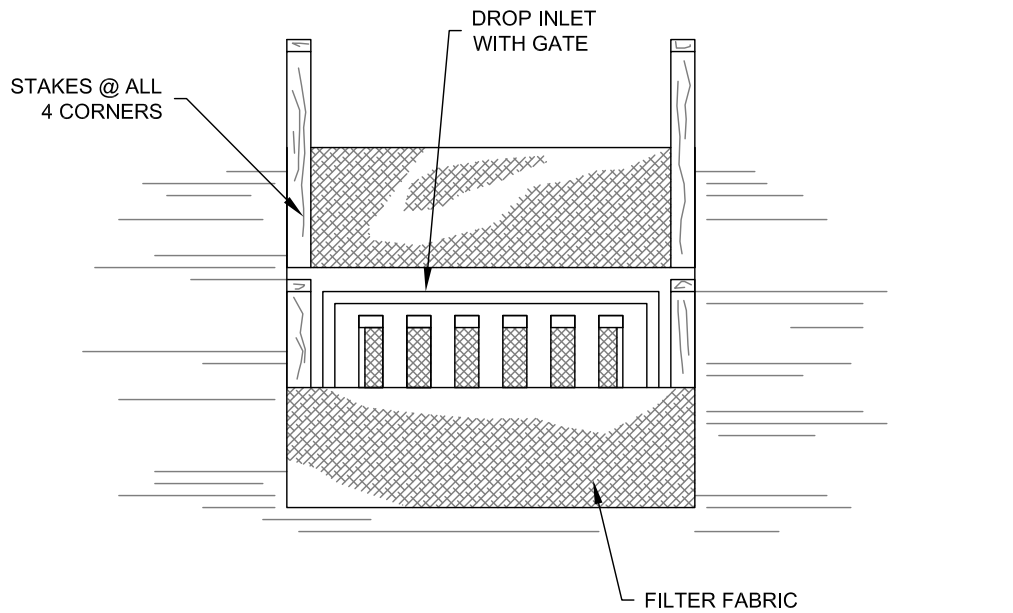

FILTER FABRIC FENCE DROP INLET FILTER

	Standard Details	Storm Drain Drop Inlet Protection	Scale: <u>N.T.S.</u>
	Stormwater Improvements		Detail No. 509

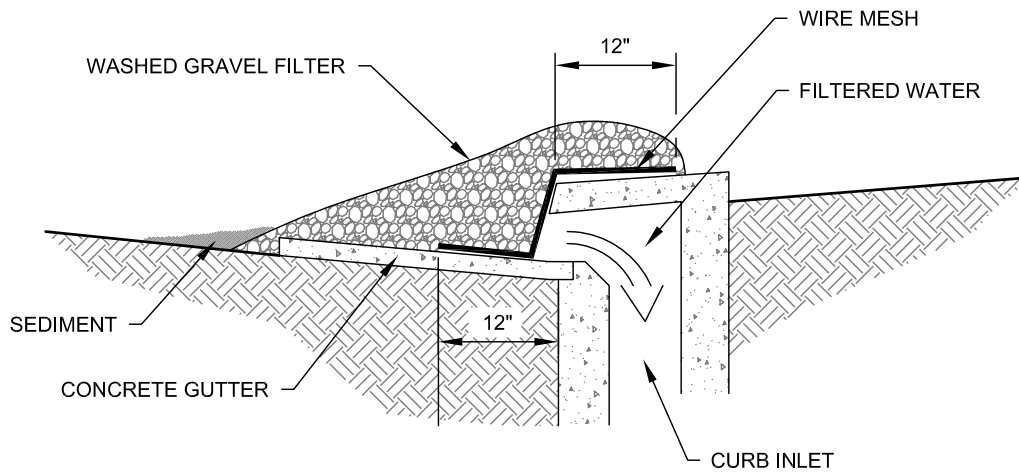
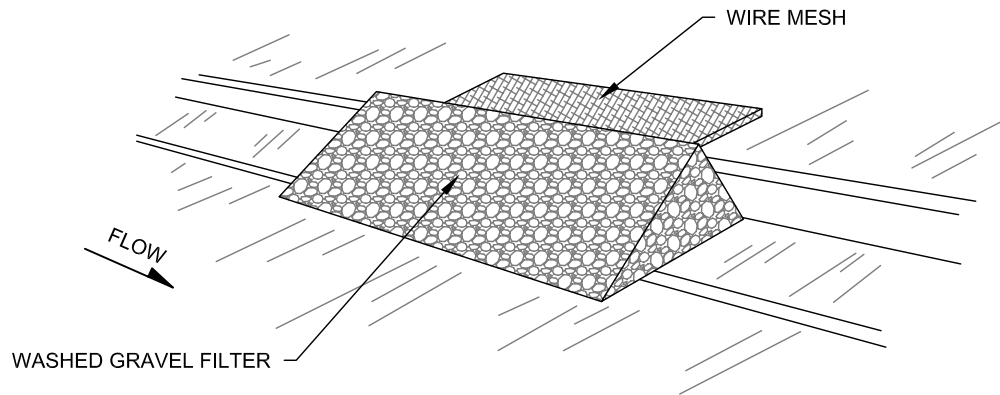

CURB INLET PROTECTION

	Standard Details	Storm Drain Curb Inlet protection	Scale: <u>N.T.S.</u>
	Stormwater Improvements		Detail No. 510

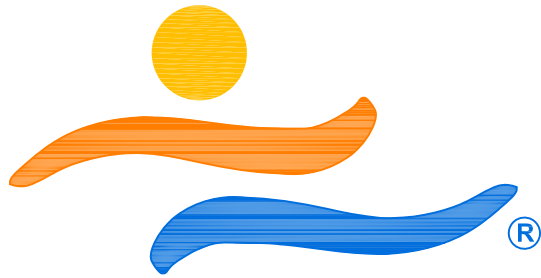

LAKE HAVASU CITY

**FIRE
IMPROVEMENTS**

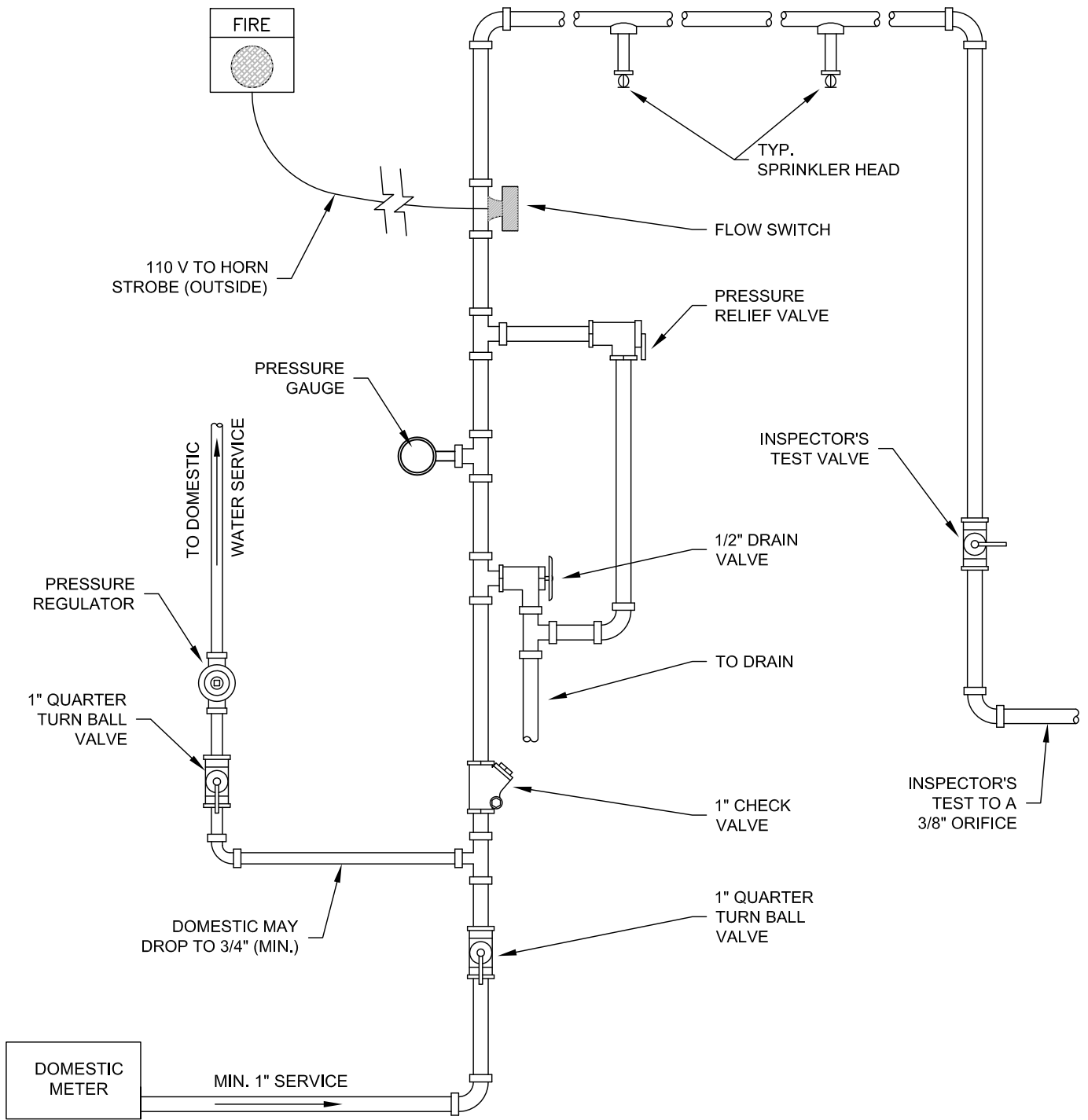

METER 3/4 STEP-UP MINIMUM SIZE REQ.

	Standard Details	Fire Department Standard Riser Detail	Scale: <u>N.T.S.</u>
	Fire Improvements		Detail No. 600