

PLAN REQUIREMENTS
FOR
ATTACHED COVERED PATIO STRUCTURES



“Build a good city by guiding the orderly physical development of Lake Havasu City in accordance with the General Plan and the community development codes and policies adopted by the City Council”

ATTACHED COVERED PATIO STRUCTURES CHECKLIST

(* applies to garage/carport conversions and patio enclosures)

ALL PLANS SHALL BE DRAWN TO SCALE

SITE PLAN

- Show distance to property lines
- Distance from main structure (applies to detached structures)
- Show location of existing septic tank and leach lines
- Approval by Mohave County Health Department

FOUNDATION PLAN

- Plan view of foundation and slab
- Footing detail

FLOOR PLAN

- Window and door sizes and location*
- Indicate use of addition, conversion or structure*
- Square footage
- Show floor plan of existing house adjacent to addition or conversion, indicating room use and window and door sizes and location with existing roof span & slope*

ROOF FRAMING PLAN

- Truss or rafter layout and spacing
- Beam and header sizes
- Truss calculations from the manufacturer

ELECTRICAL PLAN (can be shown on floor plan)

- Wall outlet locations*
- Fans and lighting fixtures*
- Switch locations*
- Exterior outlets*

EXTERIOR VIEW ELEVATIONS

- Show a minimum of two views*
- Window and door locations*
- Height of structure above grade*

DETAILS

- Roof pitch
- Roof covering
- Stud sizes and spacing*
- Wall covering*

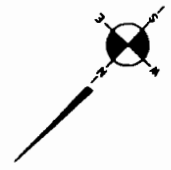
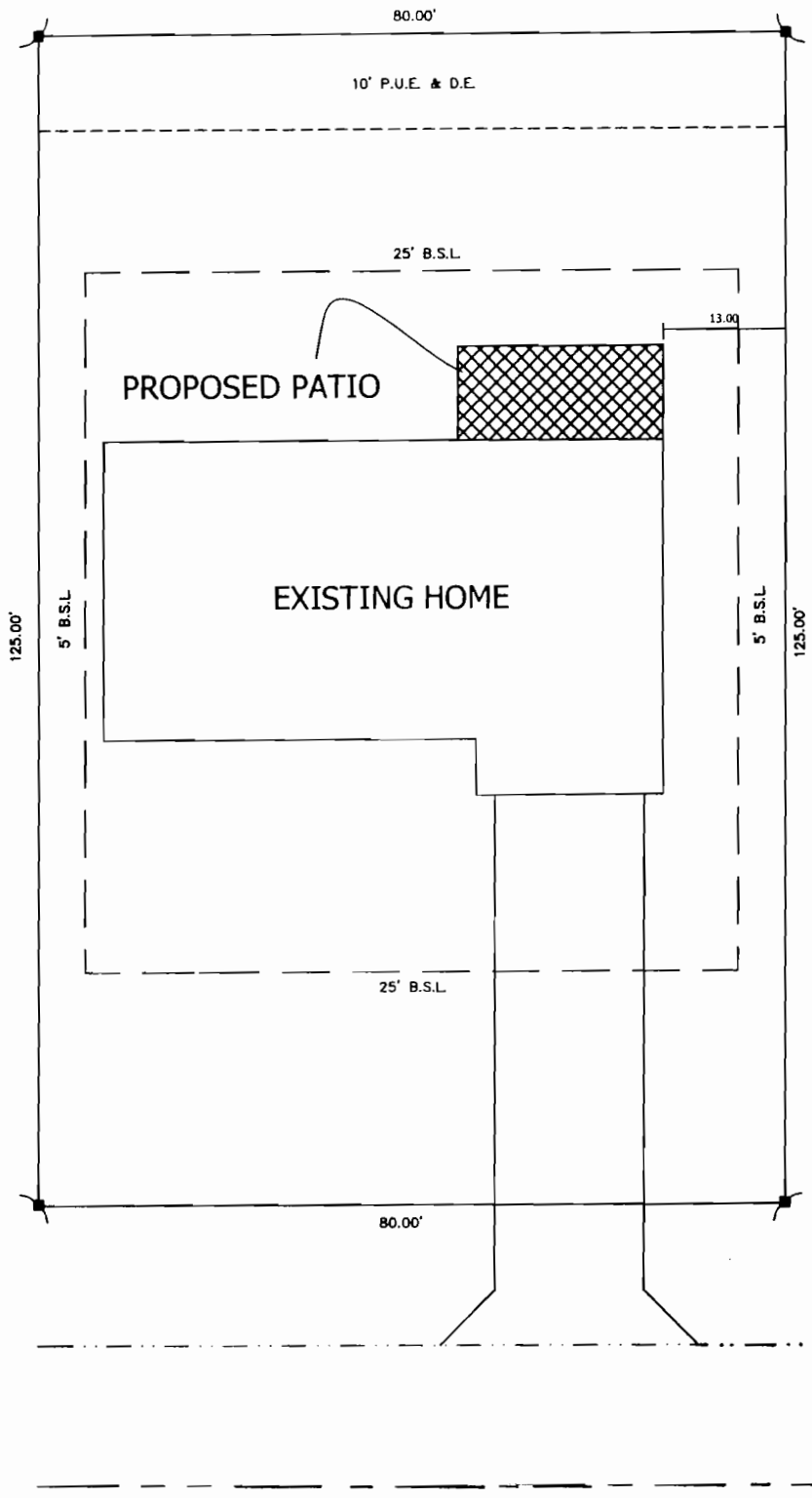

SCALE: 1" = 20'

TRACT 2157
 BLOCK 1
 LOT 9

		SITE PLAN
	SCALE: 1" = 20'	SHEET 1

EXAMPLE

Show existing window/door openings
in existing wall.

Specify existing roof span and
roof slope.

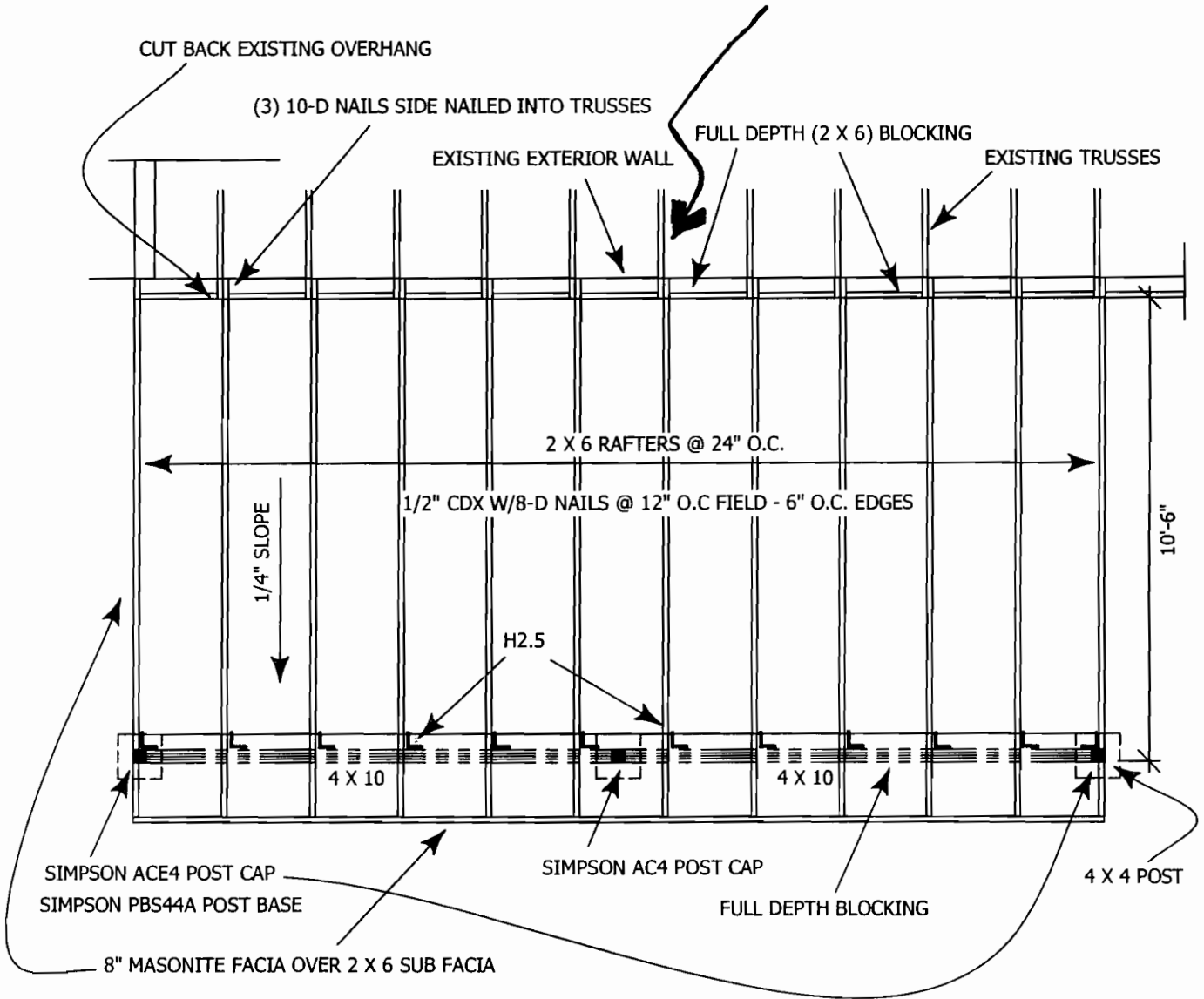

FLOOR/ROOF PLAN

220 SQUARE FEET

FLOOR/ROOF PLAN

SCALE: 1/4" = 1'

SHEET 2

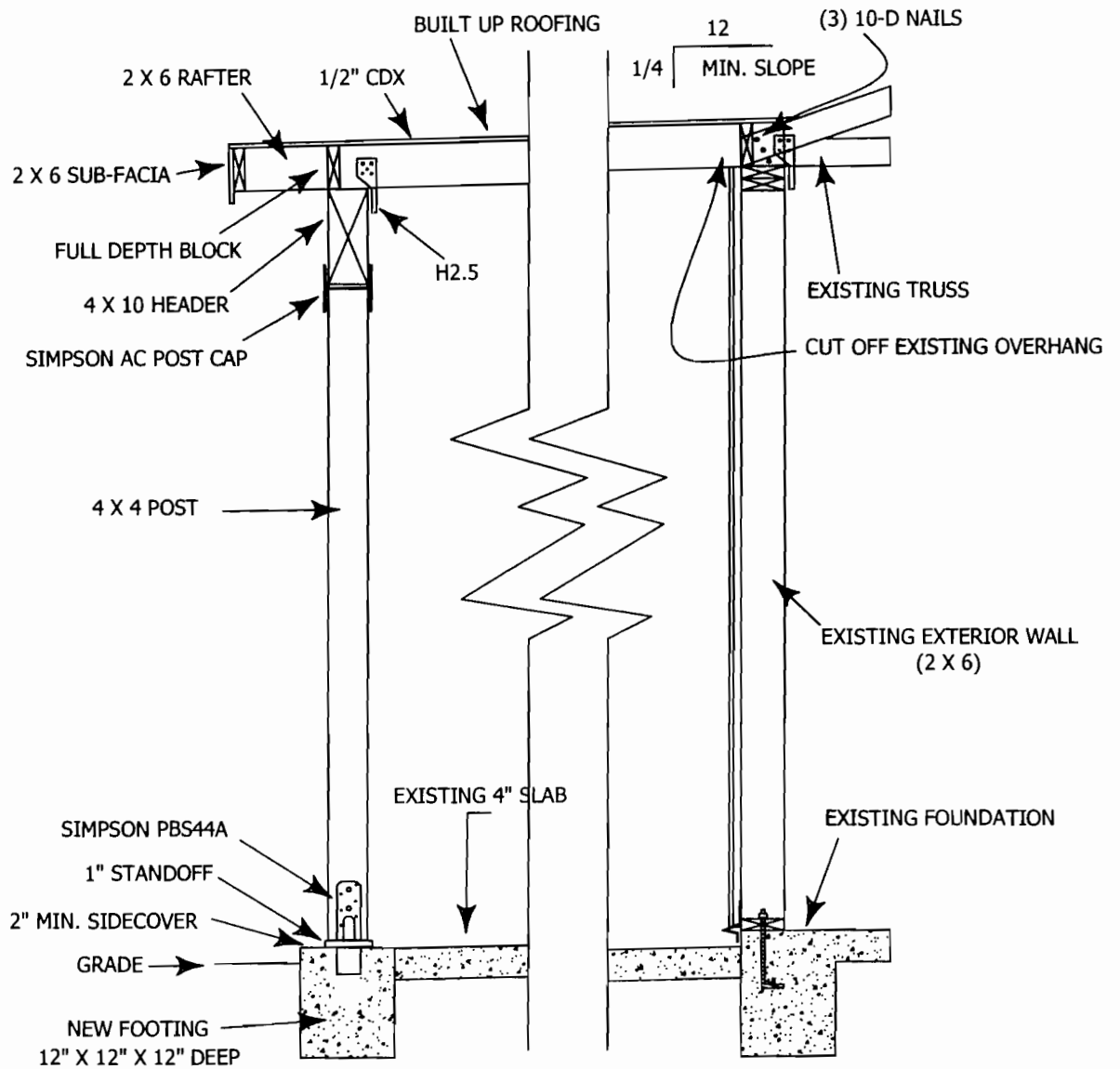

PATIO DETAIL

SCALE 1/2" = 1'

CROSS SECTION

220 SQUARE FEET

CROSS SECTION

SCALE: 1/2 = 1'

SHEET 3

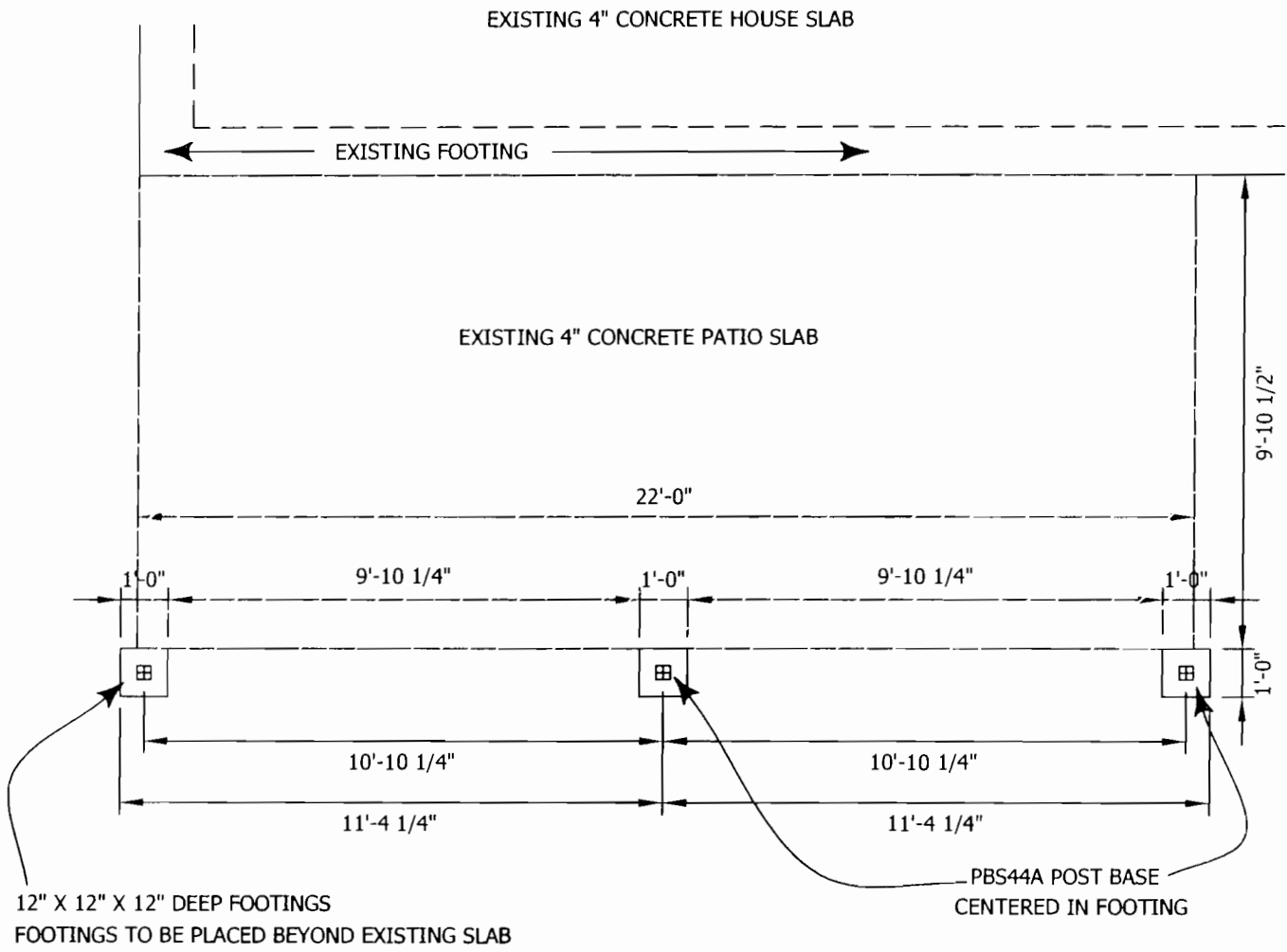

FOUNDATION PLAN

220 SQUARE FEET

		FOUNDATION PLAN
	SCALE: 1/4" = 1'	SHEET 4

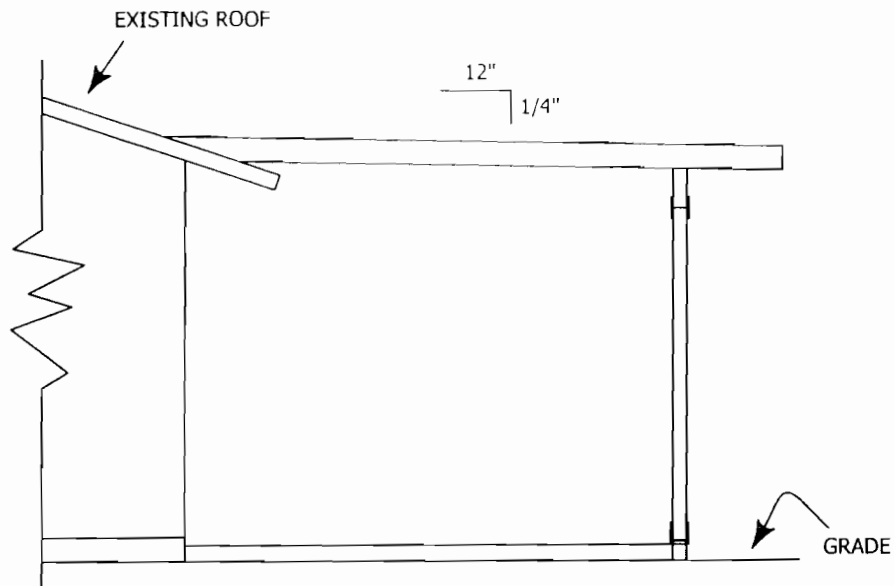
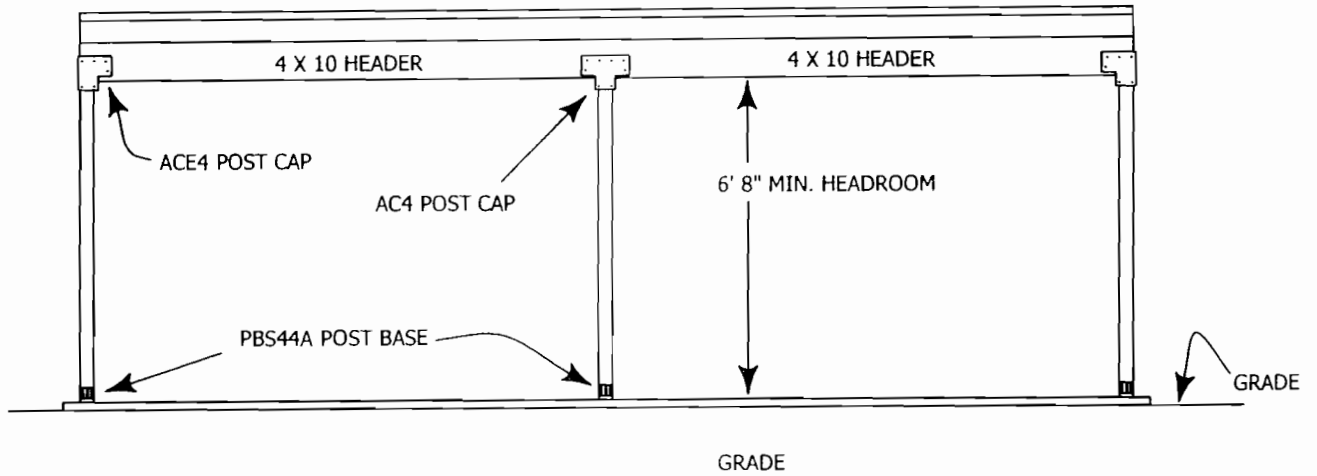

ELEVATIONS

220 SQUARE FEET

		ELEVATIONS
	SCALE: 1/4" = 1'	SHEET 5