



LAKE HAVASU CITY

Development Services Department
2330 McCulloch Boulevard North
Lake Havasu City, AZ 86403
(928) 453-4148 or 453-4149

Open Automotive Spray Booth Electrical Submittal Requirements

- Applicant shall complete a Lake Havasu City building permit application
- Applicant may prepare and shall provide a minimum of (2) sets of scaled drawings (1/4":12") indicating the following items unless it is determined to require a registrant as noted below –
 - Floor plan showing location of the proposed spray booth
 - State rating (in amperes) of the main service disconnect (not the unit subpanel)
 - Location of any existing electrical receptacle outlets, switches, lighting fixtures or electrical equipment such as subpanels, motors, transformers, etc.
 - Include illustrated hazardous locations and any electrical located within the hazardous locations (see below)

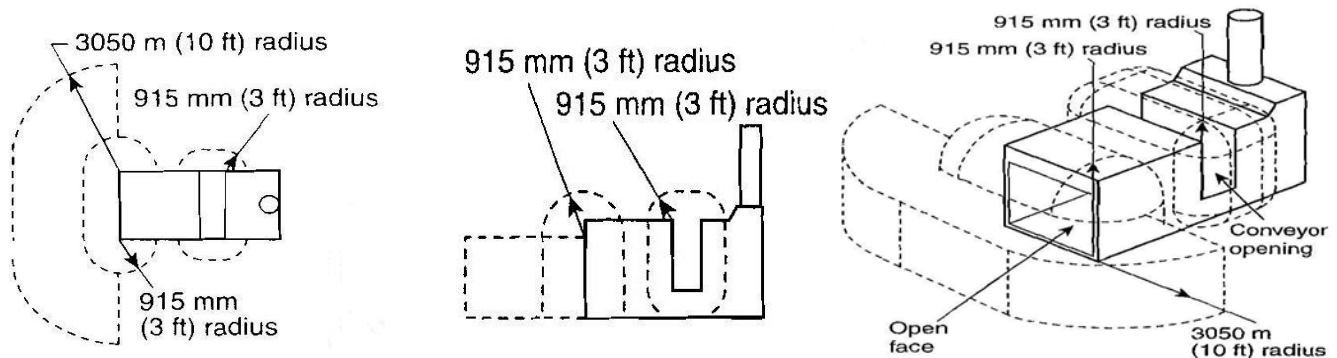

Figure 516.3(B)(2) Class I, Division 2, Class I, Zone 2, or Class II, Division 2 Locations Adjacent to a Closed Top, Open Face, or Open Front Spray Booth or Room. [NFPA 33:Figures 6.5.2(a) and 6.5.2(b)]

- A registrant may be required to seal and prepare the proposed plans if it is found that the building electrical service and the associated feeders exceeds 600 amperes @ 120/240 volts single phase or 225 amperes @ 120/208 volts three phase and the fault current exceeds 10,000 amperes per Arizona Administrative Code, Title 4, Chapter 30, Section R4-30-302A
- A registrant may be required to seal and prepare the proposed plans if it is noted that the existing or proposed electrical equipment is found to be within a hazardous location per Article 500 of the 2005 NEC per Arizona Administrative Code, Title 4, Chapter 30, Section R4-30-302B2